

# 9" Bench Band Saw

(Model BS100)



PART NO. A03049 - 03-05-04  
Copyright © 2004 Delta Machinery



To learn more about DELTA MACHINERY  
visit our website at: [www.deltamachinery.com](http://www.deltamachinery.com).

For Parts, Service, Warranty or other Assistance,

please call **1-800-223-7278** (In Canada call **1-800-463-3582**).

**ESPAÑOL: PÁGINA 25**

## SAFETY GUIDELINES - DEFINITIONS

This manual contains information that is important for you to know and understand. This information relates to protecting YOUR SAFETY and PREVENTING EQUIPMENT PROBLEMS. To help you recognize this information, we use the symbols to the right. Please read the manual and pay attention to these sections.

**▲ DANGER** Indicates an imminently hazardous situation which, if not avoided, will result in death or serious injury.

**▲ WARNING** Indicates a potentially hazardous situation which, if not avoided, could result in death or serious injury.

**▲ CAUTION** Indicates a potentially hazardous situation which, if not avoided, may result in minor or moderate injury.

**CAUTION** Used without the safety alert symbol indicates potentially hazardous situation which, if not avoided, may result in property damage.

**▲ WARNING** **SOME DUST CREATED BY POWER SANDING, SAWING, GRINDING, DRILLING, AND OTHER CONSTRUCTION ACTIVITIES** contains chemicals known to cause cancer, birth defects or other reproductive harm. Some examples of these chemicals are:

- lead from lead-based paints,
- crystalline silica from bricks and cement and other masonry products, and
- arsenic and chromium from chemically-treated lumber.

Your risk from these exposures varies, depending on how often you do this type of work. To reduce your exposure to these chemicals: work in a well ventilated area, and work with approved safety equipment, always wear **MSHA/NIOSH** approved, properly fitting face mask or respirator when using such tools.

## GENERAL SAFETY RULES



**▲ WARNING** **READ AND UNDERSTAND ALL WARNINGS AND OPERATING INSTRUCTIONS BEFORE USING THIS EQUIPMENT.** Failure to follow all instructions listed below, may result in electric shock, fire, and/or serious personal injury or property damage.

### IMPORTANT SAFETY INSTRUCTIONS

Woodworking can be dangerous if safe and proper operating procedures are not followed. As with all machinery, there are certain hazards involved with the operation of the product. Using the machine with respect and caution will considerably lessen the possibility of personal injury. However, if normal safety precautions are overlooked or ignored, personal injury to the operator may result. Safety equipment such as guards, push sticks, hold-downs, featherboards, goggles, dust masks and hearing protection can reduce your potential for injury. But even the best guard won't make up for poor judgment, carelessness or inattention. Always use common sense and exercise caution in the workshop. If a procedure feels dangerous, don't try it. Figure out an alternative procedure that feels safer. **REMEMBER:** Your personal safety is your responsibility. For additional information please visit our website [www.deltamachinery.com](http://www.deltamachinery.com).

**▲ WARNING** This machine was designed for certain applications only. Delta Machinery strongly recommends that this machine not be modified and/or used for any application other than that for which it was designed. If you have any questions relative to a particular application, **DO NOT** use the machine until you have first contacted Delta to determine if it can or should be performed on the product.

**Technical Service Manager**  
**Delta Machinery**  
**4825 Highway 45 North**  
**Jackson, TN 38305**  
**(IN CANADA: 505 SOUTHGATE DRIVE, GUELPH, ONTARIO N1H 6M7)**

# GENERAL SAFETY RULES

**▲ WARNING** FAILURE TO FOLLOW THESE RULES MAY RESULT IN SERIOUS INJURY.

- FOR YOUR OWN SAFETY, READ THE INSTRUCTION MANUAL BEFORE OPERATING THE MACHINE.** Learning the machine's application, limitations, and specific hazards will greatly minimize the possibility of accidents and injury.
- USE CERTIFIED SAFETY EQUIPMENT.** Eye protection equipment should comply with ANSI Z87.1 standards, hearing equipment should comply with ANSI S3.19 standards, and dust mask protection should comply with MSHA/NIOSH certified respirator standards. Splinters, air-borne debris, and dust can cause irritation, injury, and/or illness.
- DRESS PROPERLY.** Do not wear tie, gloves, or loose clothing. Remove watch, rings, and other jewelry. Roll up your sleeves. Clothing or jewelry caught in moving parts can cause injury.
- DO NOT USE THE MACHINE IN A DANGEROUS ENVIRONMENT.** The use of power tools in damp or wet locations or in rain can cause shock or electrocution. Keep your work area well-lit to prevent tripping or placing arms, hands, and fingers in danger.
- MAINTAIN ALL TOOLS AND MACHINES IN PEAK CONDITION.** Keep tools sharp and clean for best and safest performance. Follow instructions for lubricating and changing accessories. Poorly maintained tools and machines can further damage the tool or machine and/or cause injury.
- CHECK FOR DAMAGED PARTS.** Before using the machine, check for any damaged parts. Check for alignment of moving parts, binding of moving parts, breakage of parts, and any other conditions that may affect its operation. A guard or any other part that is damaged **should be properly repaired or replaced.** Damaged parts can cause further damage to the machine and/or injury.
- KEEP THE WORK AREA CLEAN.** Cluttered areas and benches invite accidents.
- KEEP CHILDREN AND VISITORS AWAY.** Your shop is a potentially dangerous environment. Children and visitors can be injured.
- REDUCE THE RISK OF UNINTENTIONAL STARTING.** Make sure that the switch is in the "OFF" position before plugging in the power cord. In the event of a power failure, move the switch to the "OFF" position. An accidental start-up can cause injury.
- USE THE GUARDS.** Check to see that all guards are in place, secured, and working correctly to prevent injury.
- REMOVE ADJUSTING KEYS AND WRENCHES BEFORE STARTING THE MACHINE.** Tools, scrap pieces, and other debris can be thrown at high speed, causing injury.
- USE THE RIGHT MACHINE.** Don't force a machine or an attachment to do a job for which it was not designed. Damage to the machine and/or injury may result.
- USE RECOMMENDED ACCESSORIES.** The use of accessories and attachments not recommended by Delta may cause damage to the machine or injury to the user.
- USE THE PROPER EXTENSION CORD.** Make sure your extension cord is in good condition. When using an extension cord, be sure to use one heavy enough to carry the current your product will draw. An undersized cord will cause a drop in line voltage, resulting in loss of power and overheating. See the Extension Cord Chart for the correct size depending on the cord length and nameplate ampere rating. If in doubt, use the next heavier gauge. The smaller the gauge number, the heavier the cord.
- SECURE THE WORKPIECE.** Use clamps or a vise to hold the workpiece when practical. Loss of control of a workpiece can cause injury.
- FEED THE WORKPIECE AGAINST THE DIRECTION OF THE ROTATION OF THE BLADE, CUTTER, OR ABRASIVE SURFACE.** Feeding it from the other direction will cause the workpiece to be thrown out at high speed.
- DON'T FORCE THE WORKPIECE ON THE MACHINE.** Damage to the machine and/or injury may result.
- DON'T OVERREACH.** Loss of balance can make you fall into a working machine, causing injury.
- NEVER STAND ON THE MACHINE.** Injury could occur if the tool tips, or if you accidentally contact the cutting tool.
- NEVER LEAVE THE MACHINE RUNNING UNATTENDED. TURN THE POWER OFF.** Don't leave the machine until it comes to a complete stop. A child or visitor could be injured.
- TURN THE MACHINE "OFF", AND DISCONNECT THE MACHINE FROM THE POWER SOURCE** before installing or removing accessories, before adjusting or changing set-ups, or when making repairs. An accidental start-up can cause injury.
- MAKE YOUR WORKSHOP CHILDPROOF WITH PADLOCKS, MASTER SWITCHES, OR BY REMOVING STARTER KEYS.** The accidental start-up of a machine by a child or visitor could cause injury.
- STAY ALERT, WATCH WHAT YOU ARE DOING, AND USE COMMON SENSE. DO NOT USE THE MACHINE WHEN YOU ARE TIRED OR UNDER THE INFLUENCE OF DRUGS, ALCOHOL, OR MEDICATION.** A moment of inattention while operating power tools may result in injury.
- THE DUST GENERATED** by certain woods and wood products can be injurious to your health. Always operate machinery in well-ventilated areas, and provide for proper dust removal. Use wood dust collection systems whenever possible.

# ADDITIONAL SAFETY RULES FOR BAND SAWS

**▲ WARNING** FAILURE TO FOLLOW THESE RULES MAY RESULT IN SERIOUS INJURY.

1. **DO NOT OPERATE THIS MACHINE UNTIL** it is assembled and installed according to the instructions.
2. **OBTAIN ADVICE** from your supervisor, instructor, or another qualified person if you are not familiar with the operation of this tool.
3. **FOLLOW ALL WIRING CODES** and recommended electrical connections.
4. **USE THE GUARDS WHENEVER POSSIBLE.** Check to see that they are in place, properly adjusted, secured, and working correctly.
5. **USE PROPER BLADE SIZE** and type.
6. **ADJUST THE UPPER BLADE GUIDE** so that it is about 1/8" above the workpiece.
7. **PROPERLY ADJUST** the blade tension, tracking, blade guides, and blade support bearings.
8. **KEEP ARMS, HANDS, AND FINGERS** away from the blade.
9. **AVOID AWKWARD OPERATIONS** and hand positions where a sudden slip could cause a hand to move into the blade.
10. **NEVER START THE MACHINE** before clearing the table of all objects (tools, scrap pieces, etc.).
11. **NEVER START THE MACHINE** with the workpiece against the blade.
12. **HOLD WORKPIECE FIRMLY** against the table. DO NOT attempt to saw a workpiece that does not have a flat surface against the table.
13. **HOLD WORKPIECE FIRMLY** and feed into blade at a moderate speed.
14. **NEVER REACH UNDER THE TABLE** while the machine is running.
15. **TURN THE MACHINE "OFF"** to back out of an uncompleted or jammed cut.
16. **MAKE "RELIEF" CUTS** prior to cutting long curves.
17. **TURN THE MACHINE "OFF"** and wait for the blade to stop prior to cleaning the blade area, removing debris near the blade, removing or securing workpiece, or changing the angle of the table. A coasting blade can be dangerous.
18. **NEVER PERFORM LAYOUT, ASSEMBLY,** or set-up work on the table/work area when the machine is running.
19. **TURN THE MACHINE "OFF" AND DISCONNECT THE MACHINE** from the power source before installing or removing accessories, before adjusting or changing set-ups, or when making repairs.
20. **TURN THE MACHINE "OFF"**, disconnect the machine from the power source, and clean the table/work area before leaving the machine. **LOCK THE SWITCH IN THE "OFF" POSITION** to prevent unauthorized use.
21. **ADDITIONAL INFORMATION** regarding the safe and proper operation of power tools (i.e. a safety video) is available from the Power Tool Institute, 1300 Sumner Avenue, Cleveland, OH 44115-2851 ([www.powertoolinstitute.com](http://www.powertoolinstitute.com)). Information is also available from the National Safety Council, 1121 Spring Lake Drive, Itasca, IL 60143-3201. Please refer to the American National Standards Institute ANSI 01.1 Safety Requirements for Woodworking Machines and the U.S. Department of Labor OSHA 1910.213 Regulations.

## SAVE THESE INSTRUCTIONS.

Refer to them often  
and use them to instruct others.

# POWER CONNECTIONS

A separate electrical circuit should be used for your machines. This circuit should not be less than #12 wire and should be protected with a 20 Amp time lag fuse. If an extension cord is used, use only 3-wire extension cords which have 3-prong grounding type plugs and matching receptacle which will accept the machine's plug. Before connecting the machine to the power line, make sure the switch is in the "OFF" position and be sure that the electric current is of the same characteristics as indicated on the machine. All line connections should make good contact. Running on low voltage will damage the machine.

**⚠ DANGER DO NOT EXPOSE THE MACHINE TO RAIN OR OPERATE THE MACHINE IN DAMP LOCATIONS.**

# MOTOR SPECIFICATIONS

Your machine is wired for 120 volt, 60 HZ alternating current. Before connecting the machine to the power source, make sure the switch is in the "OFF" position.

# GROUNDING INSTRUCTIONS

**⚠ DANGER THIS MACHINE MUST BE GROUNDED WHILE IN USE TO PROTECT THE OPERATOR FROM ELECTRIC SHOCK.**

1. All grounded, cord-connected machines:

In the event of a malfunction or breakdown, grounding provides a path of least resistance for electric current to reduce the risk of electric shock. This machine is equipped with an electric cord having an equipment-grounding conductor and a grounding plug. The plug must be plugged into a matching outlet that is properly installed and grounded in accordance with all local codes and ordinances.

Do not modify the plug provided - if it will not fit the outlet, have the proper outlet installed by a qualified electrician.

Improper connection of the equipment-grounding conductor can result in risk of electric shock. The conductor with insulation having an outer surface that is green with or without yellow stripes is the equipment-grounding conductor. If repair or replacement of the electric cord or plug is necessary, do not connect the equipment-grounding conductor to a live terminal.

Check with a qualified electrician or service personnel if the grounding instructions are not completely understood, or if in doubt as to whether the machine is properly grounded.

Use only 3-wire extension cords that have 3-prong grounding type plugs and matching 3-conductor receptacles that accept the machine's plug, as shown in Fig. A.

Repair or replace damaged or worn cord immediately.

2. Grounded, cord-connected machines intended for use on a supply circuit having a nominal rating less than 150 volts:

If the machine is intended for use on a circuit that has an outlet that looks like the one illustrated in Fig. A, the machine will have a grounding plug that looks like the plug illustrated in Fig. A. A temporary adapter, which looks like the adapter illustrated in Fig. B, may be used to connect this plug to a matching 2-conductor receptacle as shown in Fig. B if a properly grounded outlet is not available. The temporary adapter should be used only until a properly grounded outlet can be installed by a qualified electrician. The green-colored rigid ear, lug, and the like, extending from the adapter must be connected to a permanent ground such as a properly grounded outlet box. Whenever the adapter is used, it must be held in place with a metal screw.

**NOTE: In Canada, the use of a temporary adapter is not permitted by the Canadian Electric Code.**

**⚠ DANGER IN ALL CASES, MAKE CERTAIN THE RECEPTACLE IN QUESTION IS PROPERLY GROUNDED. IF YOU ARE NOT SURE HAVE A QUALIFIED ELECTRICIAN CHECK THE RECEPTACLE.**

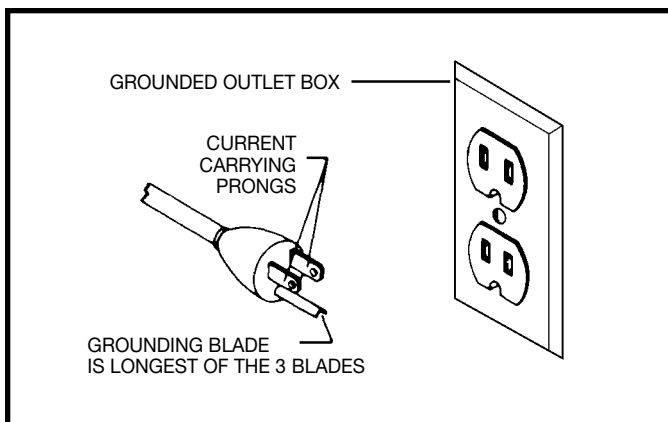

Fig. A

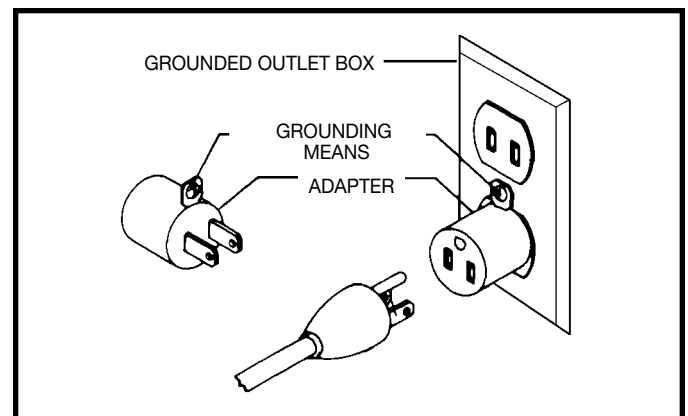

Fig. B

# EXTENSION CORDS

**CAUTION** Use proper extension cords. Make sure your extension cord is in good condition and is a 3-wire extension cord which has a 3-prong grounding type plug and matching receptacle which will accept the machine's plug. When using an extension cord, be sure to use one heavy enough to carry the current of the machine. An undersized cord will cause a drop in line voltage, resulting in loss of power and overheating. Fig. D, shows the correct gauge to use depending on the cord length. If in doubt, use the next heavier gauge. The smaller the gauge number, the heavier the cord.

| <b>MINIMUM GAUGE EXTENSION CORD</b>                         |       |                                      |                         |
|---|-------|--------------------------------------|-------------------------|
| RECOMMENDED SIZES FOR USE WITH STATIONARY ELECTRIC MACHINES |       |                                      |                         |
| Ampere Rating   | Volts | Total Length of Cord in Feet         | Gauge of Extension Cord |
| 0-6   | 120   | up to 25                             | 18 AWG                  |
|   |       | 25-50                                | 16 AWG                  |
|   |       | 50-100                               | 16 AWG                  |
|   |       | 100-150                              | 14 AWG                  |
| 6-10  | 120   | up to 25                             | 18 AWG                  |
|   |       | 25-50                                | 16 AWG                  |
|   |       | 50-100                               | 14 AWG                  |
|   |       | 100-150                              | 12 AWG                  |
| 10-12   | 120   | up to 25                             | 16 AWG                  |
|   |       | 25-50                                | 16 AWG                  |
|   |       | 50-100                               | 14 AWG                  |
|   |       | 100-150                              | 12 AWG                  |
| 12-16   | 120   | up to 25                             | 14 AWG                  |
|   |       | 25-50                                | 12 AWG                  |
|   |       | GREATER THAN 50 FEET NOT RECOMMENDED |                         |

Fig. D

# OPERATING INSTRUCTIONS

## FOREWORD

Delta ShopMaster Model BS100 is a built for precision and performance. The Delta ShopMaster Model BS100 comes with a powerful 1/3 HP motor, rack and pinion upper blade guide assembly, table tilting assembly, and a flexible lamp.

## UNPACKING AND CLEANING

Carefully unpack the machine and all loose items from the shipping container. Remove the protective coating from all unpainted surfaces. This coating may be removed with a soft cloth moistened with kerosene (do not use acetone, gasoline or lacquer thinner for this purpose). After cleaning, cover the unpainted surfaces with a good quality household floor paste wax.

**NOTICE: THE MANUAL COVER PHOTO ILLUSTRATES THE CURRENT PRODUCTION MODEL. ALL OTHER ILLUSTRATIONS ARE REPRESENTATIVE ONLY AND MAY NOT DEPICT THE ACTUAL COLOR, LABELING OR ACCESSORIES AND MAY BE INTENDED TO ILLUSTRATE TECHNIQUE ONLY.**

# 9" BENCH BAND SAW PARTS

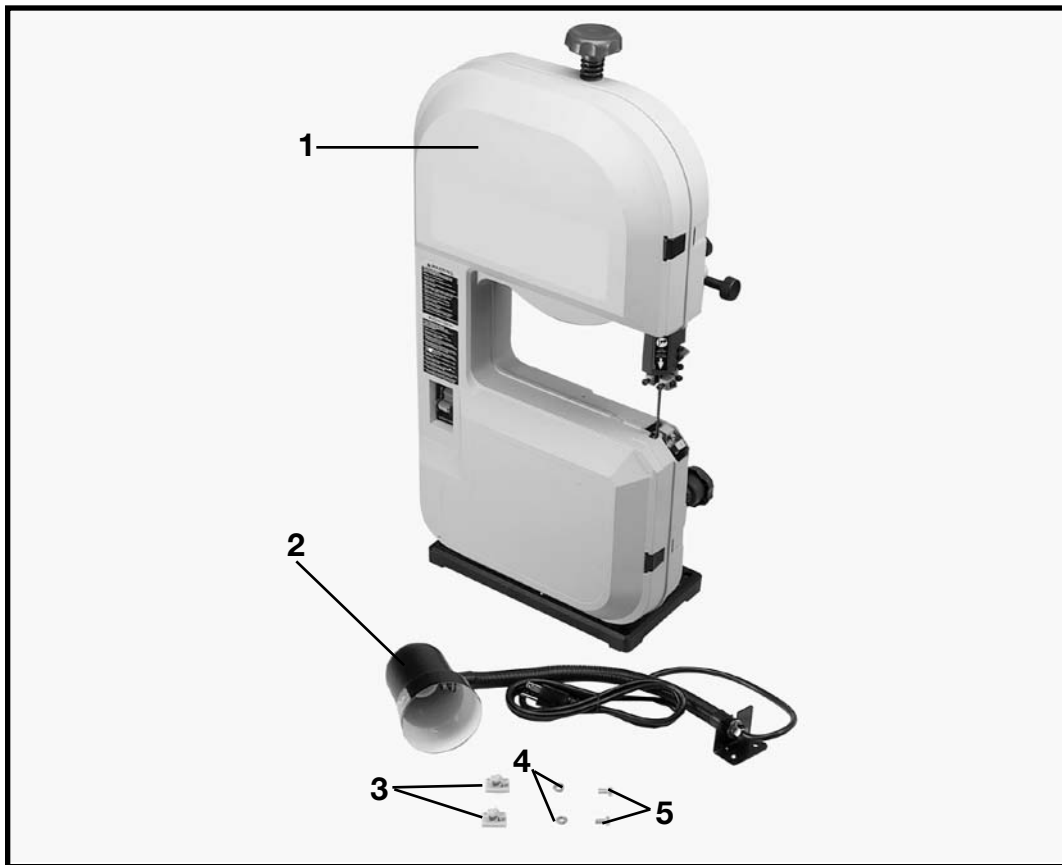

Fig. 2

- 1 - Band Saw
- 2 - Lamp
- 3 - Lamp Cord Clamps (2)
- 4 - 1/4" Lockwashers (2)
- 5 - M6x1x12mm Cap Head Screws (2)

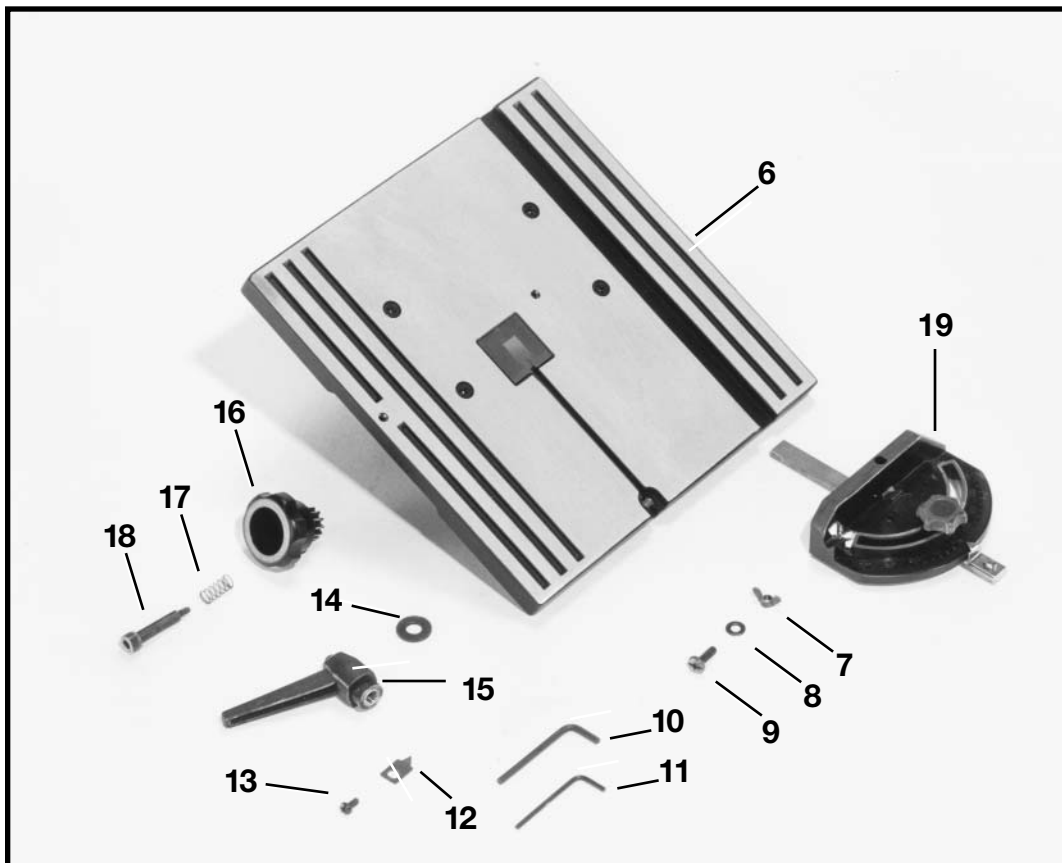

Fig. 3

- 6 - Table
- 7 - M6x1 Wing Nut
- 8 - M6 Flat Washer
- 9 - M6x1x30mm Pan Head Screw
- 10 - 4mm Hex Wrench
- 11 - 3mm Hex Wrench
- 12 - Pointer
- 13 - M5x.8x10mm Pan Head Screw
- 14 - M10 Flat Washer
- 15 - Lever Assembly
- 16 - Pinion Knob
- 17 - Spring
- 18 - Special Screw
- 19 - Miter Gauge (Optional)

# ASSEMBLY

**⚠ WARNING** FOR YOUR OWN SAFETY, DO NOT CONNECT THE MACHINE TO THE POWER SOURCE UNTIL THE MACHINE IS COMPLETELY ASSEMBLED AND YOU READ AND UNDERSTAND THE ENTIRE OWNER'S MANUAL.

## ASSEMBLING TABLE TO MACHINE

1. Locate table locking lever (shown disassembled) Fig. 4, M10 flat washer (B) and 4mm wrench (C).
2. Using the 4mm wrench (C) Fig. 4, supplied, remove screw (D) and spring (E) from handle (A) and remove handle from nut (G). Do not lose spring (E).
3. Place table (H) Fig. 5, onto the band saw frame so that stud (J) Fig. 6, and keepers (K) protrude through the slot of trunnion (L) Fig. 7.
4. Open hinged door. (See section "OPENING AND CLOSING DOOR".)
5. While pressing in on stud (M) Fig. 8 with a pencil, place an M10 flat washer (B) Fig. 7, onto stud and thread nut (G) onto stud as shown in Fig. 7.

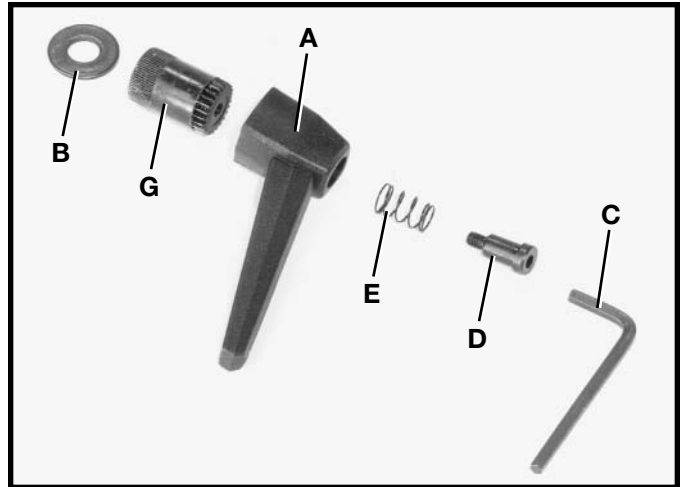

Fig. 4



Fig. 5

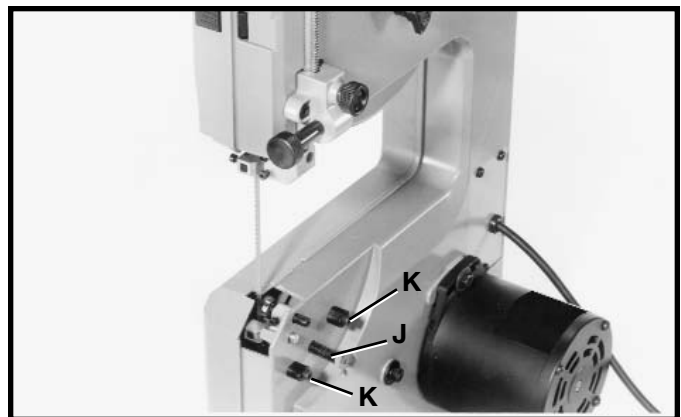

Fig. 6

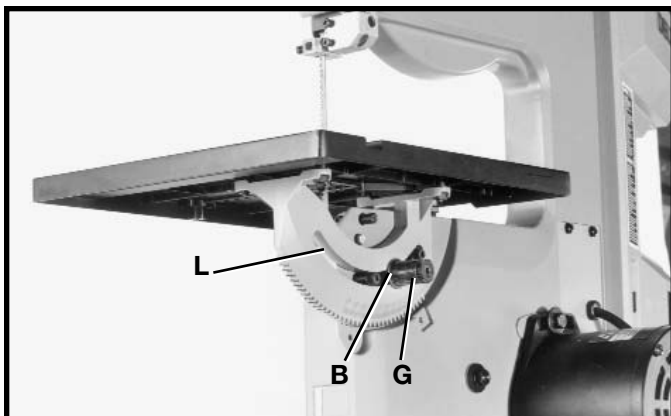

Fig. 7

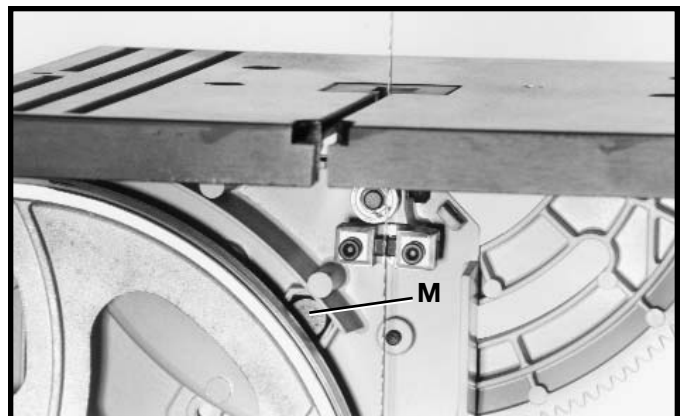

Fig. 8



6. Locate pinion knob (N) Fig. 9, spring (O), and special screw (P).

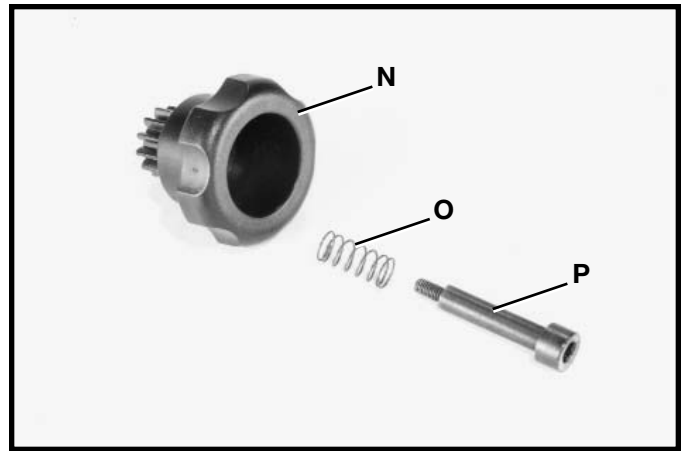

Fig. 9

7. Position pinion knob (N) Fig. 10, onto the back of saw so that the teeth on the pinion knob (N) engage the teeth on the trunnion (R). Fasten in place with special screw (P) and spring using the supplied 4mm wrench.

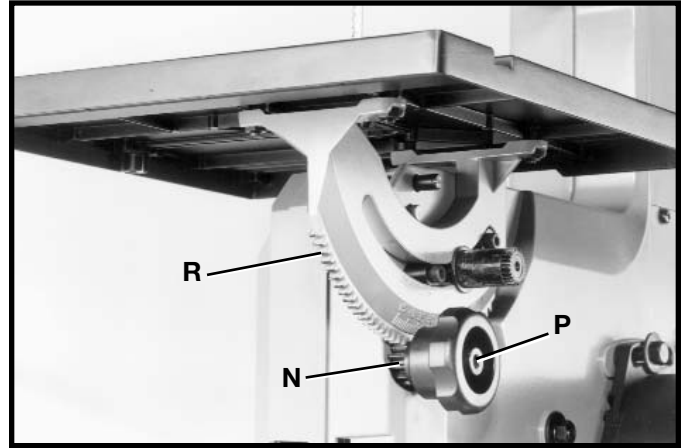

Fig. 10

8. Fasten pointer (S) Fig. 11, to the back of band saw using the M5x.8x10mm pan head screw (T).

9. Place locking handle (F) Fig. 4, onto stud (G). Place spring (E) Fig. 4, inside hole of lock handle and fasten in place with screw (D) as shown in Fig. 11. **NOTE:** Handle (F) is spring-loaded and can be repositioned on the stud by pulling out the handle and repositioning it on the nut.

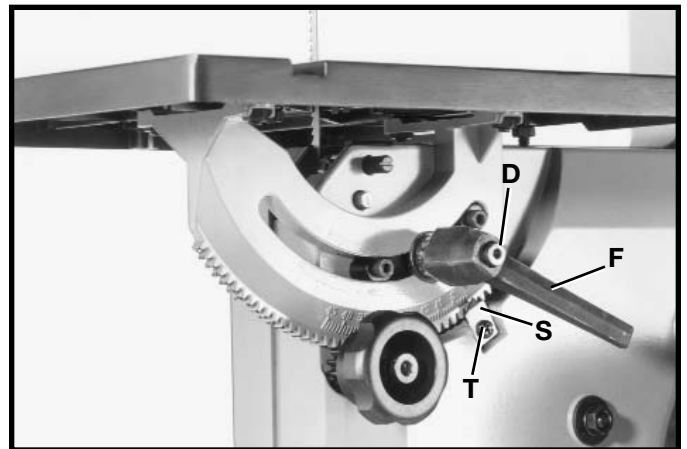

Fig. 11

10. Insert M6x1x30mm screw (W) Fig. 12, down through hole in table, as shown, and place an M6 flat washer (Z) onto the M6x1x30mm screw (W) and thread the M6x1 wing nut (X) onto screw (W) and tighten securely.

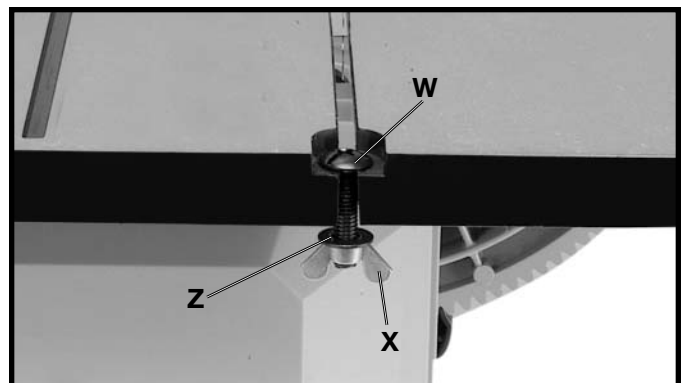

Fig. 12

## ATTACHING LAMP TO MACHINE

1. Fasten the lamp bracket (A) Fig. 13, to the top cover of the machine, using two M6x1x12mm cap head screws (B) and 1/4" lockwashers as shown.
2. Peel backing from cord clamps (C) Fig. 13A, and apply one clamp at each of the locations shown. Make certain the lamp cord is routed out of the way of the blade, then secure cord (D) to cord clamps (C) as shown in Fig. 13A.
3. The flexible lamp operates independently of the band saw. To turn the lamp on and off, rotate switch (E) Fig. 13A.

To reduce the risk of fire, use 40 watt or less, 120 volt, **⚠ WARNING** reflector track type light bulb (not supplied). A standard household light bulb should not be used. The reflector track type light bulb should not extend below the lamp shade.

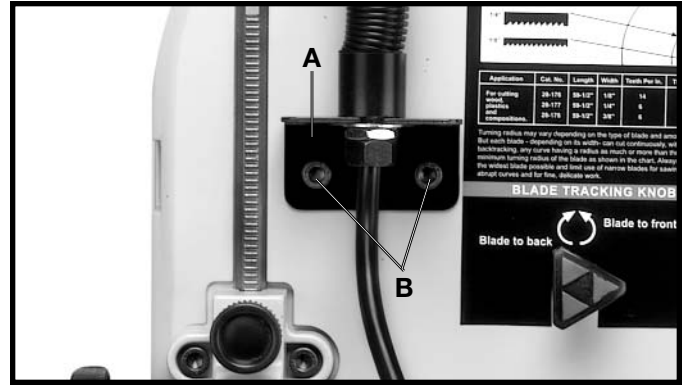

Fig. 13

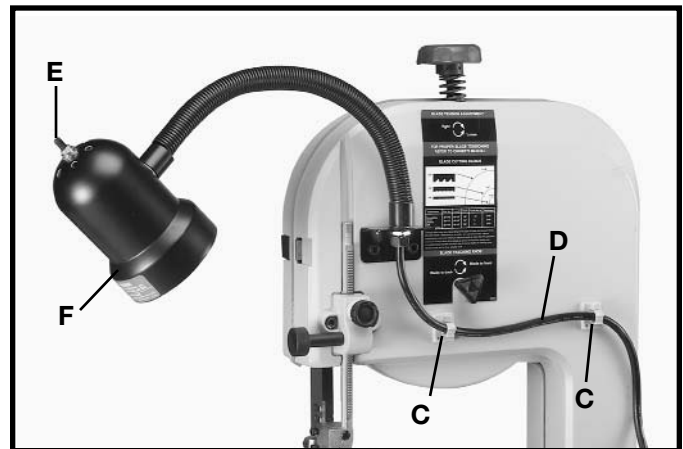

Fig. 13A

## FASTENING BAND SAW TO SUPPORTING SURFACE

If during operation there is any tendency for the machine to tip over, slide, or "walk" on the supporting surface, the machine must be secured to the supporting surface. Four holes are provided in the band saw base for this purpose, three of which are shown at (A) Fig. 14.

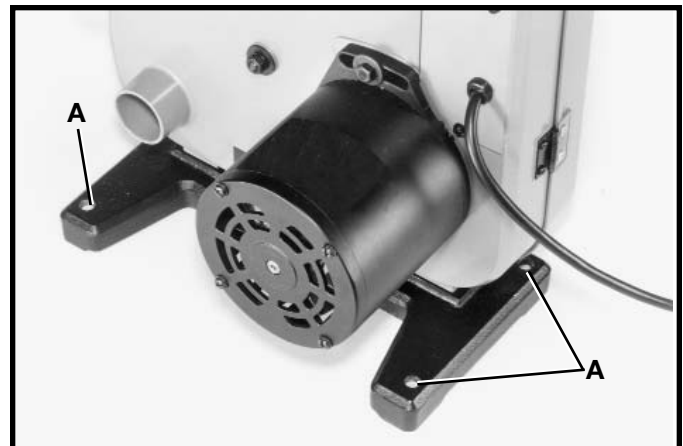

Fig. 14

# OPERATING CONTROLS AND ADJUSTMENTS

## STARTING AND STOPPING SAW

The switch (A) Fig. 15, is located on the front side of the band saw. To turn the saw “ON” move the switch (A) up to the “ON” position. To turn the saw “OFF” move the switch (A) down to the “OFF” position.



Fig. 15

## LOCKING SWITCH IN THE “OFF” POSITION

**IMPORTANT:** When the tool is not in use, the switch should be locked in the “OFF” position to prevent unauthorized use. This can be done by grasping the switch toggle (B) Fig. 16, and pulling it out of the switch, as shown. With the switch toggle (B) removed, the switch will not operate. However, should the switch toggle be removed while the machine is running, the switch can be turned “OFF” once, but cannot be restarted without inserting the switch toggle (B).

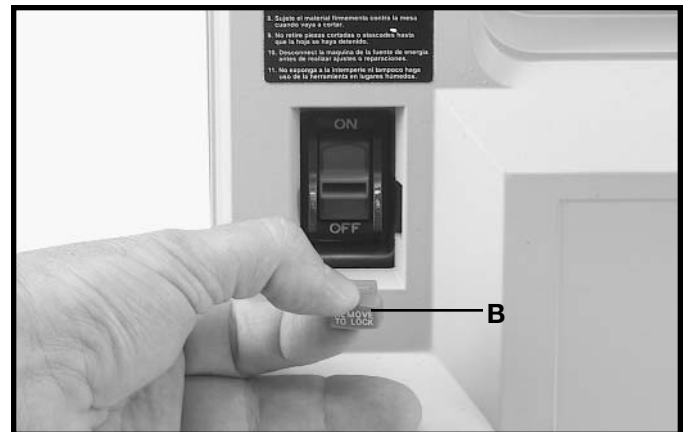

Fig. 16

## OPENING AND CLOSING DOOR

When making adjustments such as changing the blade, tracking the blade, blade guide adjustments, etc., the door (B) Figs. 17 and 18, can be opened as follows:

**⚠ WARNING NEVER OPEN THE DOOR WHEN THE MACHINE IS RUNNING.**

1. Press in the two locking latches (A) Fig. 17, and swing door (B) open.
2. Fig. 18, illustrates door (B) in open position.
3. To close and fasten door (B) Figs. 17 and 18, press on door directly over latches (A) Fig. 17, until latches snap into the locking position.

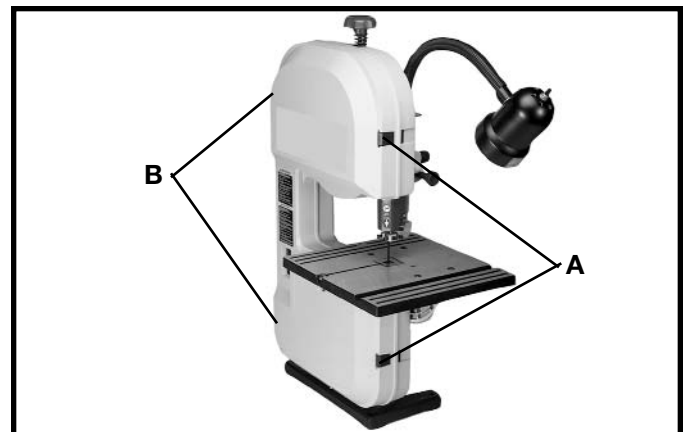

Fig. 17

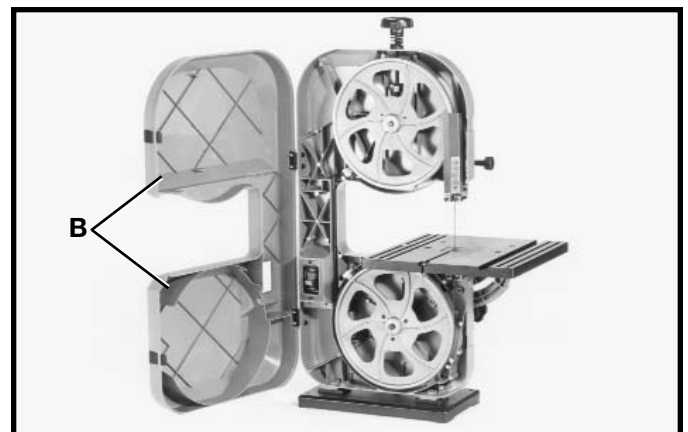

Fig. 18

# ADJUSTING BLADE TENSION

Blades of 1/8", 1/4", and 3/8" in width by 59-1/2" in length are available for use with your band saw. **NOTE:** The blade tension must be adjusted to accommodate different blade widths in order to provide proper blade tracking, cutting performance, and blade life.

**⚠ WARNING** **DISCONNECT MACHINE FROM POWER SOURCE.**

1. After the desired blade is assembled to the two wheels, turn tension knob (A) Fig. 19, clockwise until spring (B) begins to compress.
2. Turn tension knob (A) Fig. 19, an additional 2-1/2 turns for 1/8" wide blades; 3 turns for 1/4" wide blades; and 4 turns for 3/8" wide blades.
3. A chart (C) Fig. 19, is located at the rear of the band saw. This chart shows blade size, and the minimum radius that can be cut with each size blade.

# TRACKING THE BLADE

**⚠ WARNING** **DISCONNECT MACHINE FROM POWER SOURCE.**

1. Before tracking the blade, make sure the blade guides and blade support bearings are clear of the blade so as not to interfere with the tracking adjustment. Also make sure that the blade is tensioned properly. (Refer to section "ADJUSTING BLADE TENSION").
2. Open the hinged door (C) Fig. 20.
3. Rotate upper wheel (A) Fig. 20, clockwise by hand and check to see if the blade (B) rides true on the approximate center of the two wheels.
4. If an adjustment is necessary, **SLIGHTLY** turn blade tracking knob (D) Fig. 19, clockwise to move the blade to the rear, and counterclockwise to move the blade to the front. **NOTE:** Turn the blade tracking knob (D) in small intervals to adjust the blade tracking.

# ADJUSTING UPPER BLADE GUIDE ASSEMBLY

The upper blade guide assembly (A) Fig. 21, should always be no more than 1/8" above or as close as possible to the top surface of the workpiece being cut. Loosen knob (B) Fig. 21, rotate knob (C) and position the guide assembly (A) to the desired position. Then tighten knob (B).

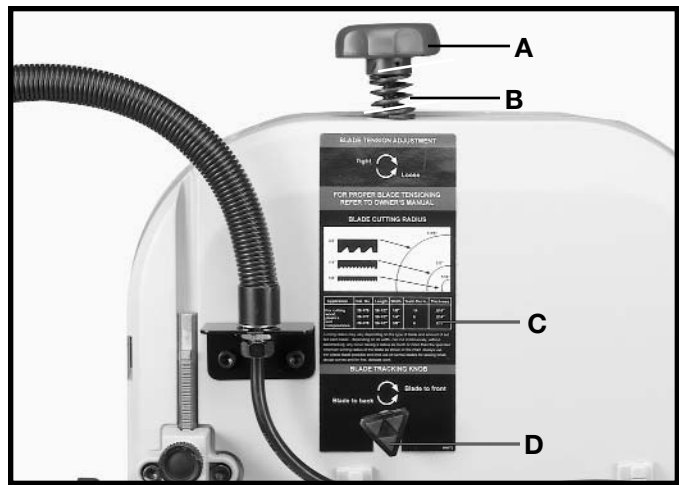

Fig. 19

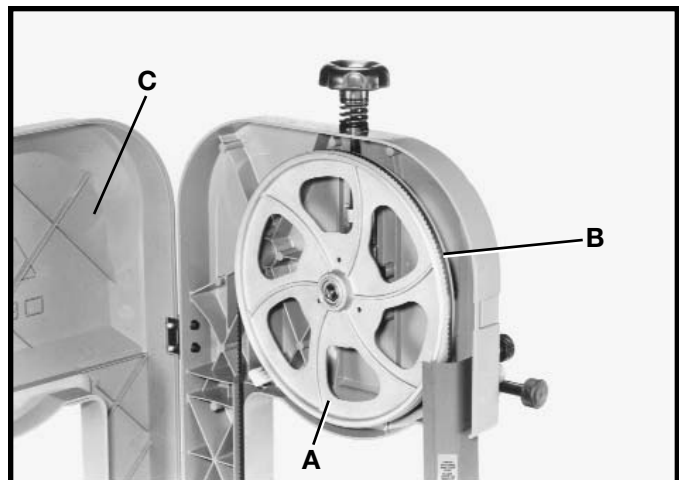

Fig. 20

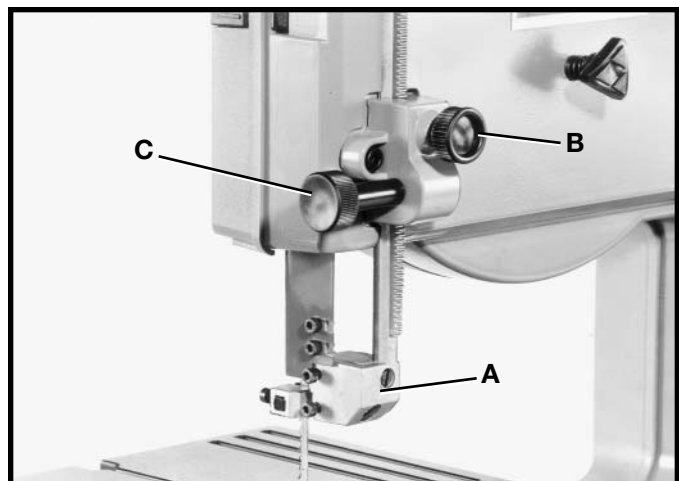

Fig. 21

# ADJUSTING UPPER BLADE GUIDES AND BLADE SUPPORT BEARING

**IMPORTANT: BOTH THE UPPER AND LOWER BLADE GUIDES MUST BE PROPERLY ADJUSTED TO PREVENT THE BLADE FROM TWISTING DURING OPERATION.**

**⚠ WARNING DISCONNECT MACHINE FROM POWER SOURCE.**

1. **NOTE:** Upper blade guard (B) Fig. 22, is shown removed for clarity.
2. Loosen the two screws (C) Fig. 22, and adjust the blade guides (D) as close as possible to the sides of the saw blade, being careful not to pinch the blade. Then tighten the two screws (C).
3. Loosen screw (E) Fig. 22, and move the guide bracket (F) in or out until the front edge of the guides (D) are just behind the “gullets” of the blade teeth. Then tighten screw (E).
4. The upper blade support/thrust bearing (G) Fig. 22, prevents the saw blade from being pushed back too far when cutting. The support bearing (G) should be adjusted approximately 1/32" behind the blade, so the back of the blade overlaps the outside diameter of the ball bearing by approximately 1/8". To adjust, proceed as follows:

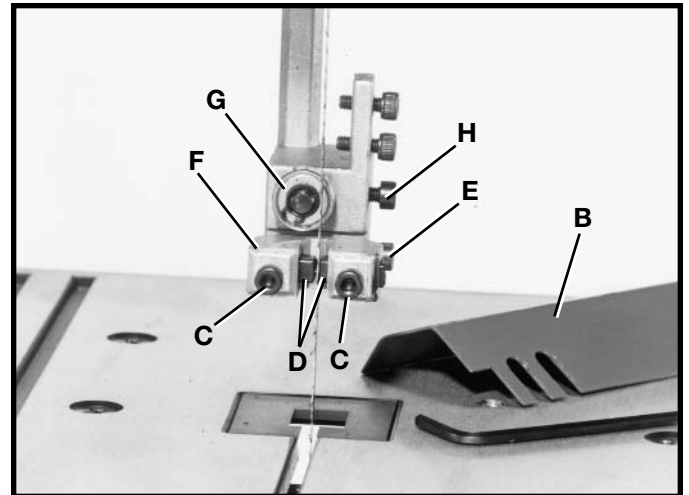

Fig. 22

**⚠ WARNING DISCONNECT MACHINE FROM POWER SOURCE.**

5. Loosen screw (H) Fig. 22, and slide support bearing (G) in or out until it is approximately 1/32" behind the saw blade.
6. The upper blade support bearing (G) Fig. 22, is set on an eccentric shaft. To change position of bearing (G), use a straight screwdriver, rotate shaft (J) Fig. 23, until the blade properly overlaps the support bearing. Then tighten screw (H).

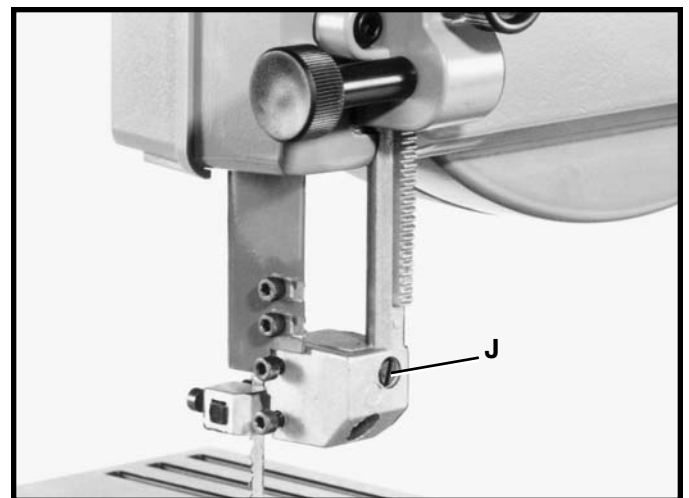

Fig. 23

# ADJUSTING LOWER BLADE GUIDES AND BLADE SUPPORT BEARING

The lower blade guides and blade support bearing should be adjusted at the same time as the upper guides and support bearings as follows:

**⚠ WARNING DISCONNECT MACHINE FROM POWER SOURCE.**

1. Loosen two screws (A) Fig. 24, and move guides (B) as close as possible to the sides of the blade, being careful not to pinch the blade. Then tighten the two screws (A).

2. The front edge of guide blocks (B) Fig. 24, should be adjusted so they are just behind the “gullets” of the blade teeth by loosening screw (C), and moving assembly (D) in or out as necessary. Then tighten screw (C).

3. The lower blade support bearing (E) Fig. 24, should be adjusted to support the rear of the blade during the cutting operation and also prevent the blade from being pushed too far to the rear which could damage the blade. The support bearing (E) Fig. 24, should be set about 1/32" behind the blade by loosening screw (F) Fig. 24, and moving shaft (G) in or out. Then tighten screw (F).

4. The lower blade support bearing (E) Fig. 24, should also be adjusted so the back of the blade overlaps the outside diameter of the ball bearing by approximately 1/8". The blade support bearing (E) is set on an eccentric shaft. To change position of bearing (E), loosen screw (F) Fig. 24, and rotate shaft (G) Figs. 24 and 25, until the blade properly overlaps the support bearing. Then tighten screw (F) Fig.24.

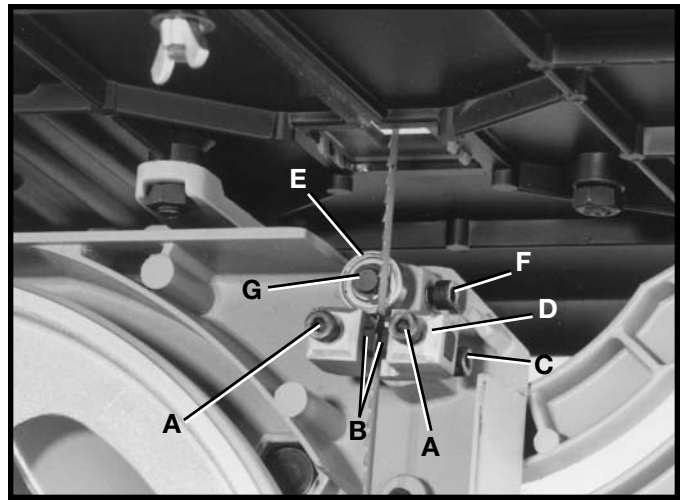

Fig. 24

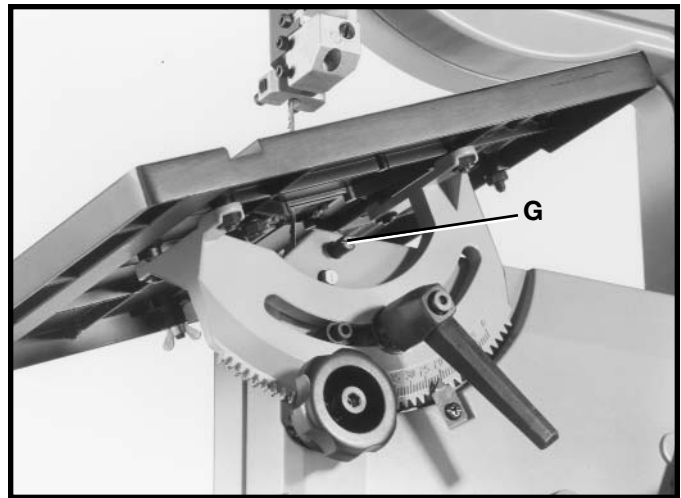

Fig. 25

## TILTING THE TABLE

The table can be tilted 45 degrees to the right. To tilt the table, loosen lock handle (A) Fig. 26, and turn knob (B) clockwise until desired angle is established. Then tighten lock handle (A). **NOTE:** The table lock handle (A) can be repositioned by pulling out on the handle and repositioning it on the nut located underneath the hub of the handle. A scale (C) and pointer (D) are provided to indicate the degree of tilt.

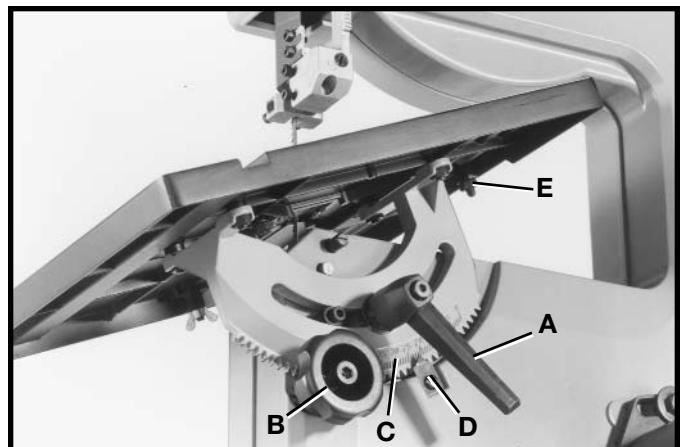

Fig. 26

# ADJUSTING THE TABLE POSITIVE STOPS

Positive stops are provided for the table at the 90 and 45 degree angle to the blade. To check and adjust the positive stops, proceed as follows:

**⚠ WARNING DISCONNECT MACHINE FROM POWER SOURCE.**

1. Tilt the table to the 90 degree position as shown in Fig. 27, and tighten lock handle (A) Fig. 28. Place a square (H) Fig. 27, on the table and against the blade and check to see if the blade is 90 degrees to the table surface. If an adjustment is necessary, proceed as follows:

2. Tilt the table slightly as shown in Fig. 26, to expose lock nut (E) Fig. 27. Loosen lock nut and return table to the 90° position. With the lock handle (A) Fig. 28 loose, turn adjusting screw (F) Fig. 27, using the wrench (G) provided until the blade is 90 degrees to the table. Then tighten lock nut (E) Fig. 27, and lock handle (A) Fig. 28.

3. Tilt the table to the 45 degree position as shown in Fig. 28. Place a square (H) on the table and against the blade and check to see if the blade is 45 degrees to the table surface. If an adjustment is necessary, proceed as follows:

4. Loosen lock nut on adjustment screw (J) Fig. 28, located on the underside of the table. With lock handle (A) Fig. 28 loose, turn adjustment screw (J) using wrench (G) provided until the blade is 45 degrees to the table. Then tighten lock handle (A), and lock nut on adjustment screw (J).

# ADJUSTING BELT TENSION

If the drive belt on your band saw needs adjustment, proceed as follows:

**⚠ WARNING DISCONNECT MACHINE FROM POWER SOURCE.**

The belt (A) Fig. 29, drives the blade wheel pulley from the motor pulley. The belt (A) is properly tensioned when there is approximately 1/4" deflection in the center span of the belt (A) using light finger pressure. If belt tension needs to be adjusted, loosen two screws (B) Fig. 30, and rotate motor accordingly. Tighten screws (B) when adjustment is completed.

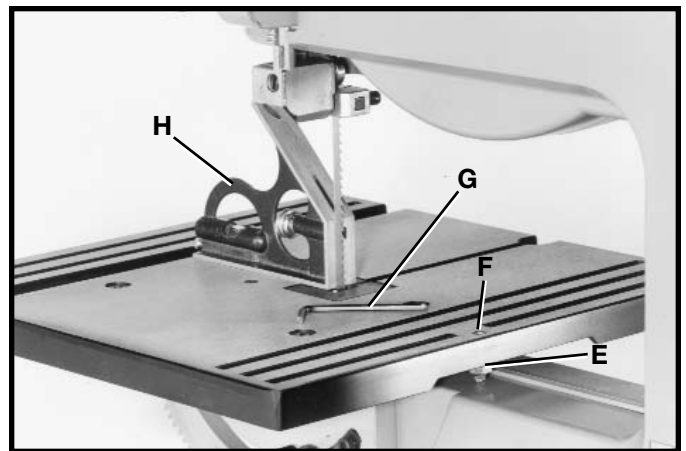

Fig. 27

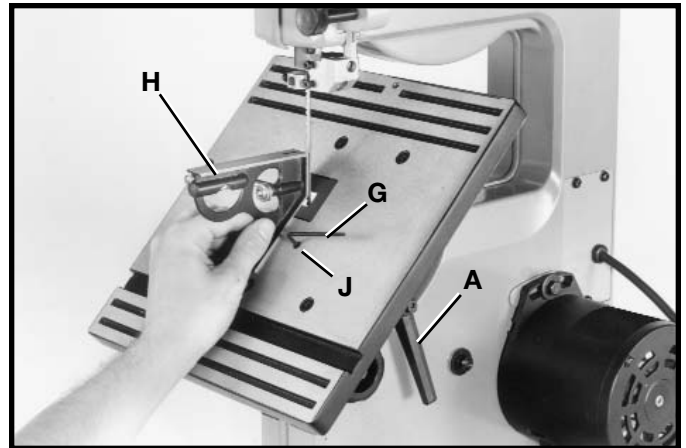

Fig. 28

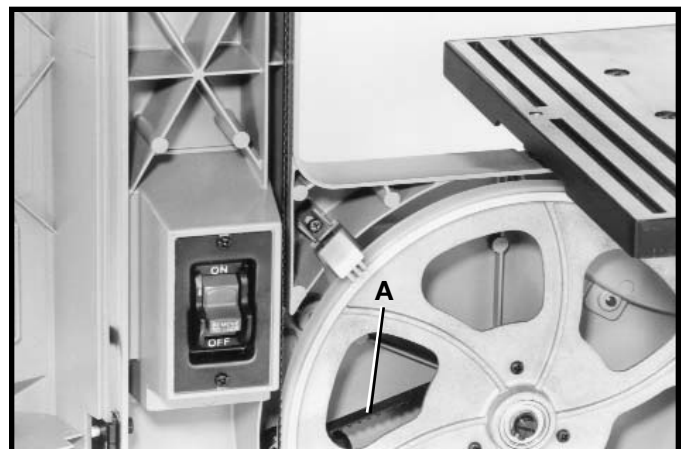

Fig. 29

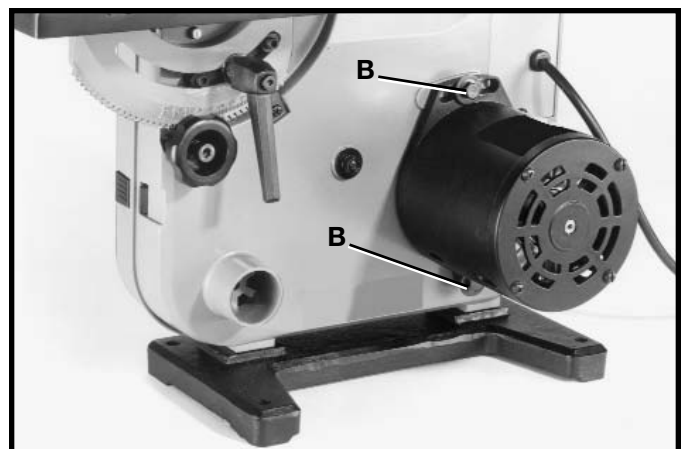

Fig. 30

# CHANGING BLADES

To change blades:

**⚠ WARNING DISCONNECT MACHINE FROM POWER SOURCE.**

1. Press in door latches (A) Fig. 34, and open door (B) as shown.
2. Loosen two screws (C) Fig. 35, and remove blade guard (D).
3. Release tension on the band saw blade by turning tension knob (E) Fig. 34 counterclockwise.
4. Remove table alignment screw (F) Fig. 36.
5. Slip the blade off both wheels and guide it out through the slot in the table.
6. Check the new blade to make sure that the teeth will point down toward the table when installed. **IF NOT, CAREFULLY TURN BLADE INSIDE OUT.**
7. Place the new blade onto wheels and adjust blade tension, blade guides and tracking as described previously in this manual.
8. Replace blade guard, which was removed in **STEP 2**, and table alignment screw which was removed in **STEP 4**.
9. Close door (B) Fig. 34, before operating saw.

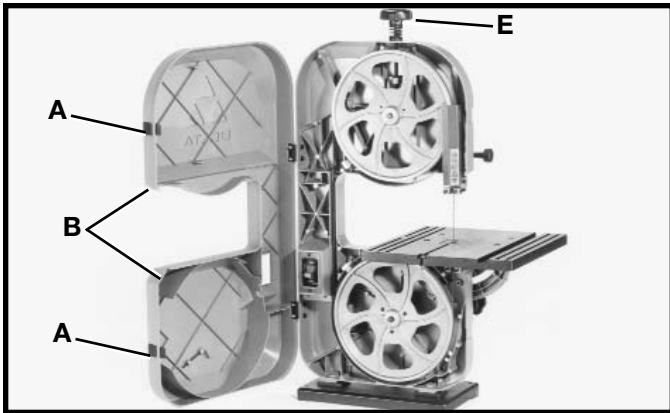

Fig. 34

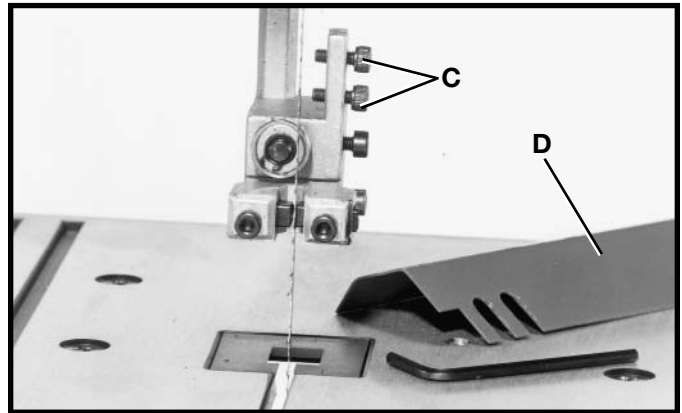

Fig. 35

## DUST CHUTE

A dust collection system can be attached to the 1¼" O.D. dust chute (A) Fig. 37.

## WRENCH STORAGE

The 3mm and 4mm wrenches (A) supplied with your band saw can be stored inside the wheel cover as shown in Fig. 37A.

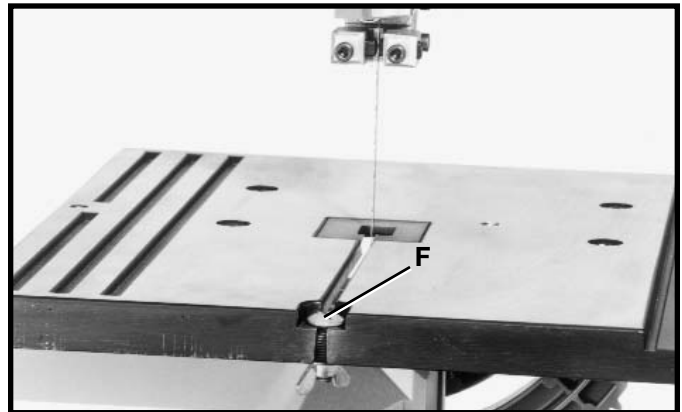

Fig. 36

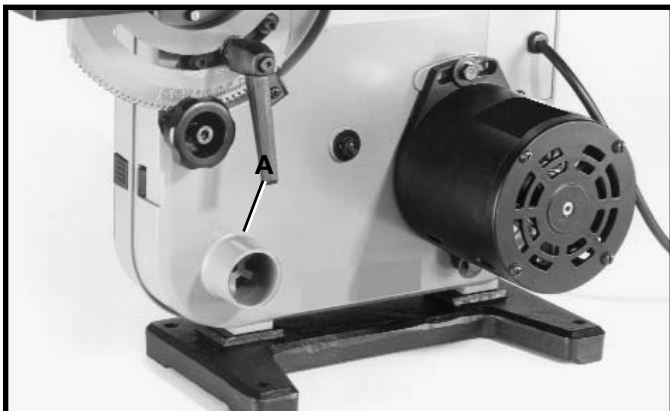

Fig. 37

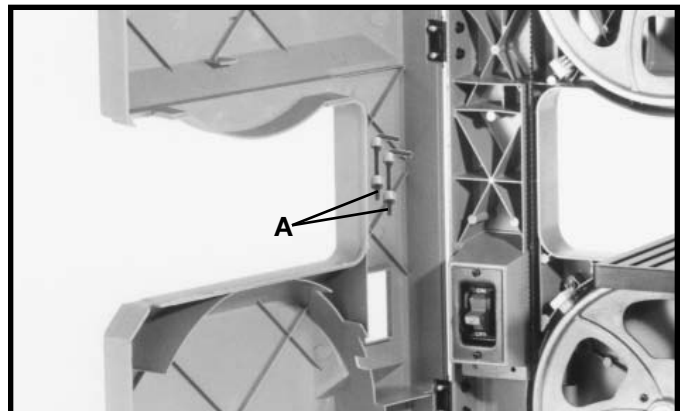

Fig. 37A



## MITER GAUGE (OPTIONAL)

Some Delta Band Saws come with a miter gauge. If your machine has a miter gauge, you can adjust it up to 45 degrees, right and left. Loosen the lock knob (A), rotate the miter gauge body (B) and tighten the lock knob (A).

Fig. 38 illustrates a typical cross-cutting operation using the accessory miter gauge. Notice how the upper blade guide assembly is set slightly above the work surface.

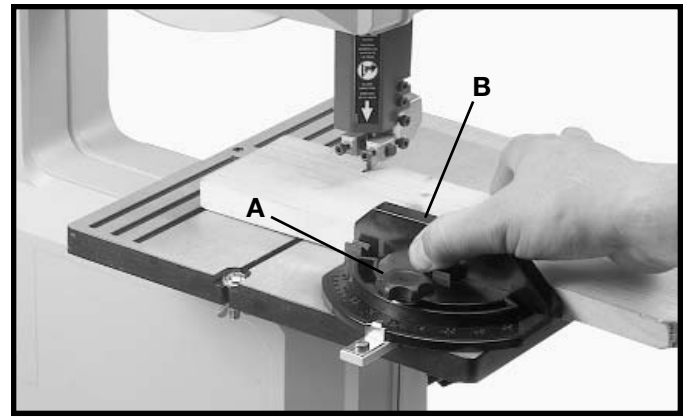

Fig. 38

## OPERATING THE BAND SAW

Before starting the machine, see that all adjustments are properly made and the guards are in place. Turn the upper wheel by hand to make sure that everything is correct **BEFORE** turning on the power.

Keep the top guide within 1/8" of the work piece at all times. Do not force the material against the blade. Light pressure on the work piece will produce a smoother cut, and prevent excess friction, heating, and hardening of the blade.

**KEEP THE SAW BLADE SHARP.** Very little forward pressure is required for normal cutting. Keep the workpiece moving at a slow and consistent rate against the blade to ensure a smooth and accurate cut.

Avoid twisting the blade by trying to turn sharp corners. Remember, you must saw around corners.

## CUTTING CURVES

When cutting curves, turn the stock carefully so that the blade follows without twisting. If a curve is so abrupt that it is necessary to repeatedly back up and cut a new kerf, a narrower blade, a blade with more set, or additional relief cuts Fig. 39, may be necessary to allow the blade to cut more efficiently. The more set a blade has, the easier it will allow the stock to be turned, but the cut is usually rougher than where a medium amount of set is used.

When withdrawing the piece being cut, changing the cut, or for any other reason, be careful not to accidentally draw the blade off the wheels. In most cases, it is easier and safer to turn the stock and saw out through the waste material, rather than try to withdraw the stock from the blade.

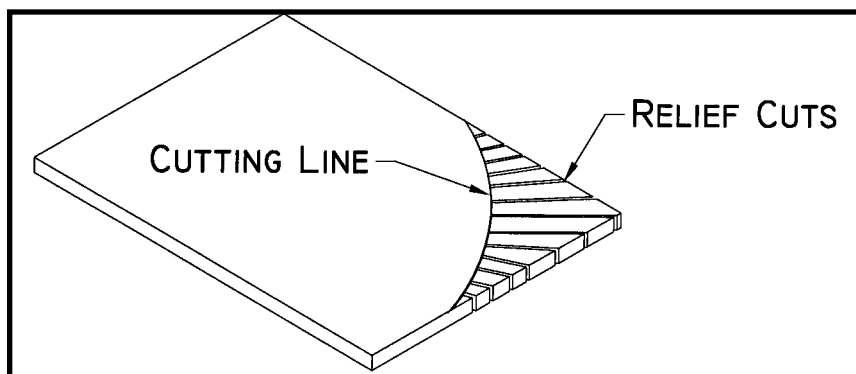
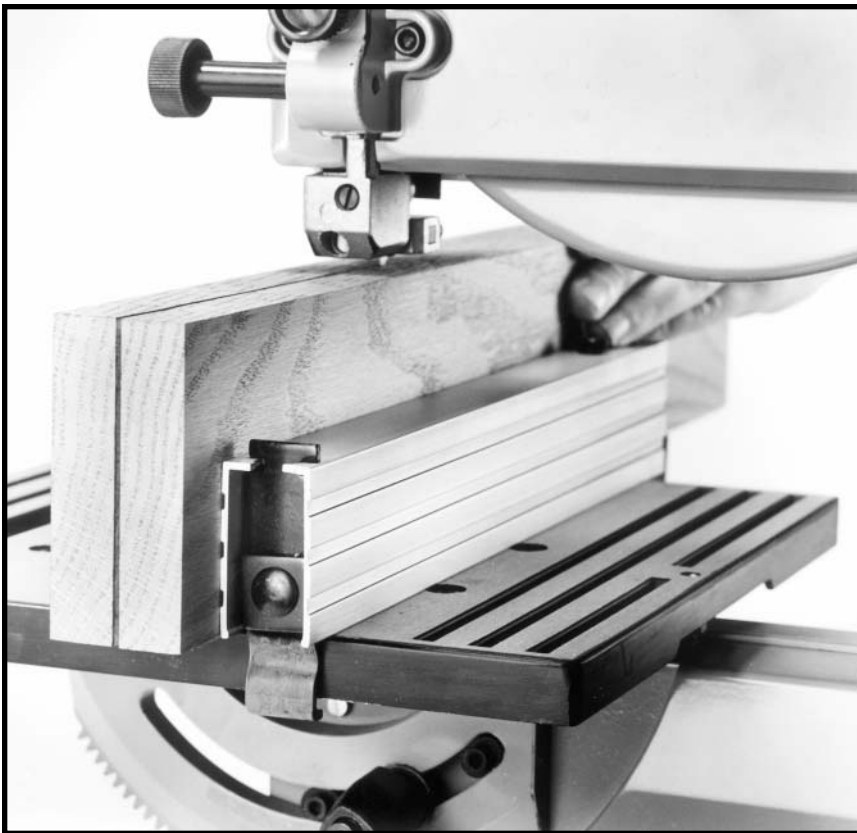

Fig. 39



**Fig. 40**

Fig. 40 illustrates a typical bevel cutting operation using the accessory miter gage.



**Fig. 41**

Fig. 41 illustrates a typical resawing application using the accessory rip fence.

# TROUBLESHOOTING GUIDE

In spite of how well a band saw is maintained, problems can occur. The following troubleshooting guide will help you solve the more common problems:

**Trouble:** *SAW WILL NOT START.*

**Probable Cause**

1. Saw not plugged in.
2. Fuse blown or circuit breaker tripped.
3. Cord damaged.

**Remedy**

1. Plug in saw.
2. Replace fuse or reset circuit breaker.
3. Have cord replaced.

**Trouble:** *BREAKER KICKS OUT FREQUENTLY.*

**Probable Cause**

1. Extension cord too light or too long.
2. Feeding stock too fast.
3. Blade in poor condition (dull, warped, gummed).
4. Low voltage supply.

**Remedy**

1. Replace with adequate size cord.
2. Feed stock more slowly.
3. Clean or replace blade.
4. Contact your electric company.

**Trouble:** *BAND SAW VIBRATES EXCESSIVELY.*

**Probable Cause**

1. Machine not mounted securely to workbench.
2. Bench on uneven surface.
3. Worn belt.
4. Belt not tensioned correctly.
5. Motor not fastened securely.

**Remedy**

1. Tighten all mounting hardware.
2. Reposition on flat level surface.
3. Replace belt.
4. Adjust belt tension by moving motor.
5. Tighten all mounting hardware.

**Trouble:** *BAND SAW DOES NOT COME UP TO SPEED.*

**Probable Cause**

1. Low voltage due to improper extension cord size.
2. Low voltage.

**Remedy**

1. Replace with adequate size cord.
2. Contact your electric company.

**Trouble:** *BLADES BREAK.*

**Probable Cause**

1. Blade not tensioned properly.
2. Blade guides improperly adjusted.
3. Blade support bearing improperly adjusted.
4. Blade wheel tracking adjustment improperly set.
5. Bad weld on blade.
6. Worn tires.
7. Forcing wide blade around short radius.
8. Dull blade or insufficient set.
9. Upper blade guide set too high.
10. Continuous running of machine when not actually cutting.

**Remedy**

1. Adjust blade tension.
2. Check and adjust blade guides.
3. Adjust blade support bearing.
4. Check and adjust blade tracking.
5. Replace the blade.
6. Replace tires.
7. Change to a narrower blade.
8. Replace blade.
9. Set upper blade guide within 1/8" of workpiece.
10. Turn off machine when not performing cutting operation.

*(continued on next page)*

# TROUBLESHOOTING GUIDE

(CONTINUED)

**Trouble:** *BLADE WILL NOT TRACK.*

**Probable Cause**

1. Blade too loose
2. Upper wheel not properly adjusted.
3. Improperly adjusted blade support bearing.

**Remedy**

1. Adjust tension
2. Adjust upper wheel.
3. Adjust blade support bearing.

**Trouble:** *CUT DOES NOT AGREE WITH SETTING ON THE TILT SCALE.*

**Probable Cause**

1. Pointer out of adjustment

**Remedy**

1. Adjust pointer.

**Trouble:** *BLADE WILL NOT STAY ON WHEEL.*

**Probable Cause**

1. Blade not tensioned properly.
2. Blade guides improperly adjusted.
3. Blade support bearing improperly adjusted.
4. Blade wheel not tracking properly.
5. Bad weld on blade.
6. Worn tires.

**Remedy**

1. Adjust blade tension.
2. Check and adjust blade guides.
3. Adjust blade support bearing.
4. Check and adjust blade tracking.
5. Replace the blade.
6. Replace tires.

**Trouble:** *BAND SAW MAKES UNSATISFACTORY CUTS.*

**Probable Cause**

1. Blade not tensioned properly.
2. Blade guides improperly adjusted.
3. Blade support bearing improperly set.
4. Blade wheel not tracking properly.
5. Bad weld on blade.
6. Worn tires.
7. Incorrect blade for work being done.
8. Dull blade or insufficient set.
9. Upper blade guide set too high.
10. Continuous running of machine when not actually cutting.

**Remedy**

1. Adjust blade tension.
2. Check and adjust blade guides.
3. Adjust blade support bearing.
4. Check and adjust blade tracking.
5. Replace the blade.
6. Replace tires.
7. Change the blade.
8. Replace blade.
9. Set upper blade guide within 1/8" of work piece.
10. Turn off machine when not performing cutting operation.

# BAND SAW BLADES

A band saw blade is a delicate piece of steel that is subjected to tremendous strain. You can obtain long use from a band saw blade if you use it properly. Be sure you use blades of the proper thickness, width and temper for the various types of material and cuts.

Always use the widest blade possible. Use narrow blades only for sawing small, abrupt curves and for fine, delicate work. This will save blades and will produce better cuts. For cutting wood and similar materials, Delta offers blades in widths of 1/8", 1/4", and 3/8".

Any one of a number of conditions may cause a band saw blade to break. Blade breakage is, in some cases, unavoidable, being the natural result of the peculiar stresses to which blades are subjected. Blades will brake often due to avoidable causes, such as the lack of care to the blade or the blade not being properly adjusted to the band saw. The most common causes of blade breakage are:

- (1) faulty alignments and adjustments of the guides.
- (2) forcing or twisting a wide blade around a curve of short radius.
- (3) feeding the work piece to fast into the blade.
- (4) dullness of the teeth, or absence of sufficient set.
- (5) excessive tensioning of the blade.
- (6) top guide set too high above the work piece being cut.
- (7) using a blade with a lumpy or improperly finished braze or weld.
- (8) continuous running of the saw blade when the blade is not in use.

Use blades that are 59½" in length on this machine.

Always use a sharp blade. Keep it free from gum and pitch. Clean frequently with a stiff fiber brush.

Narrow blades are used for cutting small circles or curves while the wider blades are best suited for straight cutting such as ripping.

A new blade, in most cases, will perform better and last longer than a re-sharpened blade.

Insure that the blade guides are adjusted properly.

Do not force or twist the blade around a curve or a very short radius.

Feed the workpiece through the blade at a consistent rate, allow the blade to do the cutting – do not feed the work piece too fast.

Do not apply excessive tension to the blade. The tension is only necessary to drive the blade without slipping on the wheels. Narrow blades require less tension than wider blades.

# NOTES

# NOTES

# ACCESSORIES

A complete line of accessories is available from your Delta Supplier, Porter-Cable • Delta Factory Service Centers, and Delta Authorized Service Stations. Please visit our Web Site [www.deltamachinery.com](http://www.deltamachinery.com) for a catalog or for the name of your nearest supplier.

**▲WARNING** Since accessories other than those offered by Delta have not been tested with this product, use of such accessories could be hazardous. For safest operation, only Delta recommended accessories should be used with this product.



## PARTS, SERVICE OR WARRANTY ASSISTANCE

All Delta Machines and accessories are manufactured to high quality standards and are serviced by a network of Porter-Cable • Delta Factory Service Centers and Delta Authorized Service Stations. To obtain additional information regarding your Delta quality product or to obtain parts, service, warranty assistance, or the location of the nearest service outlet, please call 1-800-223-7278 (In Canada call 1-800-463-3582).



### Two Year Limited New Product Warranty

Delta will repair or replace, at its expense and at its option, any new Delta machine, machine part, or machine accessory which in normal use has proven to be defective in workmanship or material, provided that the customer returns the product prepaid to a Delta factory service center or authorized service station with proof of purchase of the product within two years and provides Delta with reasonable opportunity to verify the alleged defect by inspection. For all refurbished Delta product, the warranty period is 180 days. Delta may require that electric motors be returned prepaid to a motor manufacturer's authorized station for inspection and repair or replacement. Delta will not be responsible for any asserted defect which has resulted from normal wear, misuse, abuse or repair or alteration made or specifically authorized by anyone other than an authorized Delta service facility or representative. Under no circumstances will Delta be liable for incidental or consequential damages resulting from defective products. This warranty is Delta's sole warranty and sets forth the customer's exclusive remedy, with respect to defective products; all other warranties, express or implied, whether of merchantability, fitness for purpose, or otherwise, are expressly disclaimed by Delta.



## PORTER-CABLE • DELTA SERVICE CENTERS (CENTROS DE SERVICIO DE PORTER-CABLE • DELTA)

Parts and Repair Service for Porter-Cable • Delta Machinery are Available at These Locations  
(Obtenga Refaccion de Partes o Servicio para su Herramienta en los Siguietes Centros de Porter-Cable • Delta)

### ARIZONA

Tempe 85282 (Phoenix)  
2400 West Southern Avenue  
Suite 105  
Phone: (602) 437-1200  
Fax: (602) 437-2200

### CALIFORNIA

Ontario 91761 (Los Angeles)  
3949A East Guasti Road  
Phone: (909) 390-5555  
Fax: (909) 390-5554

San Leandro 94577 (Oakland)  
3039 Teagarden Street  
Phone: (510) 357-9762  
Fax: (510) 357-7939

### COLORADO

Arvada 80003 (Denver)  
8175 Sheridan Blvd., Unit S  
Phone: (303) 487-1809  
Fax: (303) 487-1868

### FLORIDA

Davie 33314 (Miami)  
4343 South State Rd. 7 (441)  
Unit #107  
Phone: (954) 321-6635  
Fax: (954) 321-6638

Tampa 33609

4538 W. Kennedy Boulevard  
Phone: (813) 877-9585  
Fax: (813) 289-7948

### GEORGIA

Forest Park 30297 (Atlanta)  
5442 Frontage Road,  
Suite 112  
Phone: (404) 608-0006  
Fax: (404) 608-1123

### ILLINOIS

Addison 60101 (Chicago)  
400 South Rohlwing Rd.  
Phone: (630) 424-8805  
Fax: (630) 424-8895

Woodridge 60517 (Chicago)

2033 West 75th Street  
Phone: (630) 910-9200  
Fax: (630) 910-0360

### MARYLAND

Elkridge 21075 (Baltimore)  
7397-102 Washington Blvd.  
Phone: (410) 799-9394  
Fax: (410) 799-9398

### MASSACHUSETTS

Braintree 02185 (Boston)  
719 Granite Street  
Phone: (781) 848-9810  
Fax: (781) 848-6759

Franklin 02038 (Boston)  
Franklin Industrial Park  
101E Constitution Blvd.  
Phone: (508) 520-8802  
Fax: (508) 528-8089

### MICHIGAN

Madison Heights 48071 (Detroit)  
30475 Stephenson Highway  
Phone: (248) 597-5000  
Fax: (248) 597-5004

### MINNESOTA

Minneapolis 55429  
5522 Lakeland Avenue North  
Phone: (763) 561-9080  
Fax: (763) 561-0653

### MISSOURI

North Kansas City 64116  
1141 Swift Avenue  
Phone: (816) 221-2070  
Fax: (816) 221-2897

St. Louis 63119

7574 Watson Road  
Phone: (314) 968-8950  
Fax: (314) 968-2790

### NEW YORK

Flushing 11365-1595 (N.Y.C.)  
175-25 Horace Harding Expwy.  
Phone: (718) 225-2040  
Fax: (718) 423-9619

### NORTH CAROLINA

Charlotte 28270  
9129 Monroe Road, Suite 115  
Phone: (704) 841-1176  
Fax: (704) 708-4625

### OHIO

Columbus 43214  
4560 Indianola Avenue  
Phone: (614) 263-0929  
Fax: (614) 263-1238

Cleveland 44125  
8001 Sweet Valley Drive  
Unit #19  
Phone: (216) 447-9030  
Fax: (216) 447-3097

### OREGON

Portland 97230  
4916 NE 122 nd Ave.  
Phone: (503) 252-0107  
Fax: (503) 252-2123

### PENNSYLVANIA

Willow Grove 19090  
520 North York Road  
Phone: (215) 658-1430  
Fax: (215) 658-1433

### TEXAS

Carrlton 75006 (Dallas)  
1300 Interstate 35 N, Suite 112  
Phone: (972) 446-2996  
Fax: (972) 446-8157

Houston 77038

4321 Sam Houston Parkway,  
West  
Suite 180  
Phone: (281) 260-8887  
Fax: (281) 260-9989

### WASHINGTON

Auburn 98001 (Seattle)  
3320 West Valley HWY, North  
Building D, Suite 111  
Phone: (253) 333-8353  
Fax: (253) 333-9613

Authorized Service Stations are located in many large cities. Telephone **800-438-2486** or **731-541-6042** for assistance locating one. Parts and accessories for Porter-Cable-Delta products should be obtained by contacting any Porter-Cable-Delta Distributor, Authorized Service Center, or Porter-Cable-Delta Factory Service Center. If you do not have access to any of these, call **800-223-7278** and you will be directed to the nearest Porter-Cable-Delta Factory Service Center. Las Estaciones de Servicio Autorizadas están ubicadas en muchas grandes ciudades. Llame al **800-438-2486** ó al **731-541-6042** para obtener asistencia a fin de localizar una. Las piezas y los accesorios para los productos Porter-Cable-Delta deben obtenerse poniéndose en contacto con cualquier distribuidor Porter-Cable-Delta, Centro de Servicio Autorizado o Centro de Servicio de Fábrica Porter-Cable-Delta. Si no tiene acceso a ninguna de estas opciones, llame al **800-223-7278** y le dirigirán al Centro de Servicio de Fábrica Porter-Cable-Delta más cercano.

## CANADIAN PORTER-CABLE • DELTA SERVICE CENTERS

### ALBERTA

Bay 6, 2520-23rd St. N.E.  
Calgary, Alberta  
T2E 8L2  
Phone: (403) 735-6166  
Fax: (403) 735-6144

### BRITISH COLUMBIA

8520 Baxter Place  
Burnaby, B.C.  
V5A 4T8  
Phone: (604) 420-0102  
Fax: (604) 420-3522

### MANITOBA

1699 Dublin Avenue  
Winnipeg, Manitoba  
R3H 0H2  
Phone: (204) 633-9259  
Fax: (204) 632-1976

### ONTARIO

505 Southgate Drive  
Guelph, Ontario  
N1H 6M7  
Phone: (519) 767-4132  
Fax: (519) 767-4131

### QUÉBEC

1515 ave.  
St-Jean Baptiste, Suite 160  
Québec, Québec  
G2E 5E2  
Phone: (418) 877-7112  
Fax: (418) 877-7123

1447, Begin  
St-Laurent, (Montréal),  
Québec  
H4R 1V8  
Phone: (514) 336-8772  
Fax: (514) 336-3505

The following are trademarks of PORTER-CABLE-DELTA (Las siguientes son marcas registradas de PORTER-CABLE S.A.): Auto-Set®, BAMMER®, B.O.S.S.®, Builder's Saw®, Contractor's Saw®, Contractor's Saw II™, Delta®, DELTACRAFT®, DELTAGRAM™, Delta Series 2000™, DURATRONIC™, Emc<sup>2</sup>™, FLEX®, Flying Chips™, FRAME SAW®, Homecraft®, INNOVATION THAT WORKS®, Jet-Lock®, JETSTREAM®, 'kickstand®, LASERLOC®, MICRO-SET®, Micro-Set®, MIDI LATHE®, MORTEN™, NETWORK™, OMNIIJIG®, POCKET CUTTER®, PORTA-BAND®, PORTA-PLANE®, PORTER-CABLE®&(design), PORTER-CABLE®PROFESSIONAL POWER TOOLS, Posi-Matic®, Q-3®&(design), QUICKSAND®&(design), QUICKSET™, QUICKSET II®, QUICKSET PLUS™, RIPTIDE™&(design), SAFE GUARD II®, SAFE-LOC®, Sanding Center®, SANDTRAP®&(design), SAW BOSS®, Sawbuck™, Sidekick®, SPEED-BLOC®, SPEEDMATIC®, SPEEDTRONIC®, STAIR EASE®, The American Woodshop®&(design), The Lumber Company®&(design), THE PROFESSIONAL EDGE®, THE PROFESSIONAL SELECT®, THIN-LINE™, TIGER®, TIGER CUB®, TIGER SAW®, TORQBUSTER®, TORQ-BUSTER®, TRU-MATCH™, TWIN-LITE®, UNIGUARD®, Unifence®, UNIFEEDER™, Unihead®, Uniplane™, Unirip®, Unisaw®, Univise®, Versa-Feeder®, VERSA-PLANE®, WHISPER SERIES®, WOODWORKER'S CHOICE™.

Trademarks noted with ™ and ® are registered in the United States Patent and Trademark Office and may also be registered in other countries. Las Marcas Registradas con el signo de ™ y ® son registradas por la Oficina de Registros y Patentes de los Estados Unidos y también pueden estar registradas en otros países.