

# **Instruction Manual**

## **6" Belt & 10" Disc Sander**

### **1765**

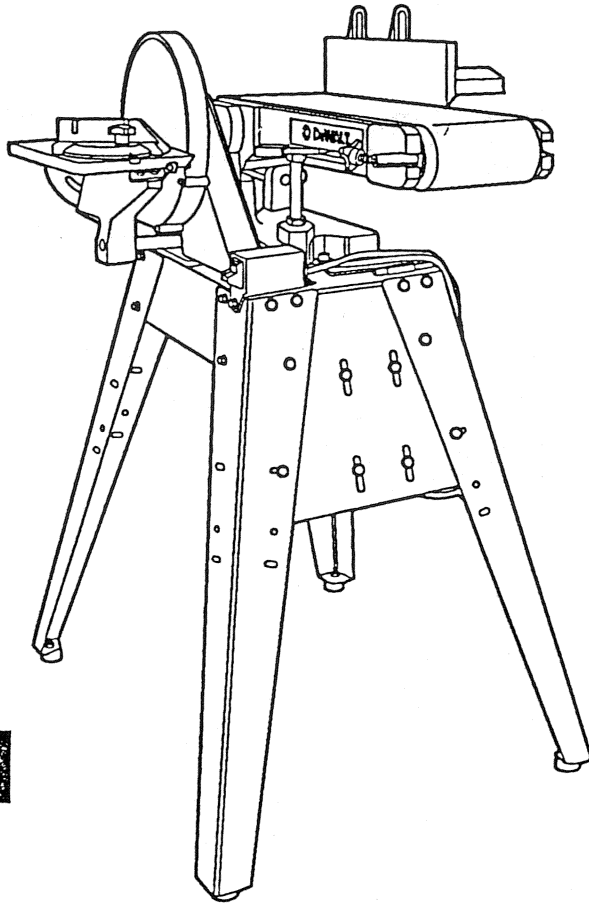

# Welcome to DeWalt's World of Heavy Duty Stationary Power Tools

If you already own a DeWalt Heavy Duty Stationary Power Tool, you know the pleasure of working with a real professional.

This new stationary Belt/Disc Sander is built to those same rigid quality standards that have made DeWalt the most respected name in stationary power tools.

With this tool you can sand horizontally or vertically with the big 6" wide belt or use the 10" diameter disc with the tilting work table and miter gauge when a little extra control is needed.

We want you to enjoy your sander and the more you know about it, the happier you'll be. Whether you're a seasoned pro or a novice, please take the time to thoroughly read this informative instruction manual and pay particular attention to the safety rules we've provided for your protection.

Don't forget to send in the owner's registration card.

THANKS FOR BUYING DEWALT.



## Important Safety Instructions (For All Tools)

**WARNING:** When using electric tools, basic safety precautions should always be followed to reduce the risk of fire, shock, and personal injury, including the following:

### READ ALL INSTRUCTIONS

1. **KEEP GUARDS IN PLACE** and in working order.
2. **REMOVE ADJUSTING KEYS AND WRENCHES.** Form habit of checking to see that keys and adjusting wrenches are removed from tool before turning it on.
3. **KEEP WORK AREA CLEAN.** Cluttered areas and benches invite accidents.
4. **DON'T USE IN DANGEROUS ENVIRONMENT.** Don't use power tools in damp or wet locations, or expose them to rain. Keep work area well lighted.
5. **KEEP CHILDREN AWAY.** All visitors should be kept at a safe distance from work area.
6. **MAKE WORKSHOP KID PROOF** with padlocks, master switches, or by removing starter keys.
7. **DON'T FORCE TOOL.** It will do the job better and be safer at the rate for which it was designed.
8. **USE RIGHT TOOL.** Don't force tool or attachment to do a job for which it was not designed.
9. **WEAR PROPER APPAREL.** No loose clothing, gloves, neckties, rings, bracelets, or other jewelry to get caught in moving parts. Nonslip footwear is recommended. Wear protective hair covering to contain long hair.
10. **ALWAYS WEAR SAFETY GLASSES.** Also use face or dust mask if cutting operation is dusty. Everyday eyeglasses have only impact resistant lenses. They are **NOT** safety glasses.
11. **SECURE WORK.** Use clamps or vise to hold work when practical. It's safer than using your hand and it frees both hands to operate tool.
12. **DON'T OVERREACH.** Keep proper footing and balance at all times.
13. **MAINTAIN TOOLS WITH CARE.** Keep tools sharp and clean for best and safest performance. Follow instructions for lubricating and changing accessories.
14. **DISCONNECT TOOLS** before servicing; when changing accessories such as blades, bits, cutters, etc.
15. **REDUCE THE RISK OF UNINTENTIONAL STARTING.** Make sure switch is in OFF position before plugging in.
16. **USE RECOMMENDED ACCESSORIES.** Consult the instruction manual for recommended accessories. The use of improper accessories may cause risk of injury to persons.
17. **NEVER STAND ON TOOL.** Serious injury could occur if the tool is tipped or if the cutting tool is unintentionally contacted.
18. **CHECK DAMAGED PARTS.** Before further use of the tool, a guard or other part that is damaged should be carefully checked to determine that it will operate properly and perform its intended function—check for alignment of moving parts, binding of moving parts, breakage of parts, mounting and any other conditions that may affect its operation. A guard or other part that is damaged should be properly repaired or replaced.
19. **DIRECTION OF FEED.** Feed work into a blade or cutter against the direction of rotation of the blade or cutter only.
20. **NEVER LEAVE TOOL RUNNING UNATTENDED. TURN POWER OFF.** Don't leave tool until it comes to a complete stop.
21. **DO NOT OPERATE ELECTRIC TOOLS NEAR FLAMMABLE LIQUIDS OR IN GASEOUS OR EXPLOSIVE ATMOSPHERES.** Motors in these tools may spark and ignite fumes.

## SAVE THESE INSTRUCTIONS

## Additional Safety Rules For the Belt and Disc Sander

- Never stand or have an observer stand in line with the abrasive belt or disc.
- Work area should have adequate light and surrounding work space should be clear.
- The Belt and Disc Sander is intended for indoor use only.
- Always wear eye protection and during extended operation use ear protection.
- Always avoid awkward hand positions, where a sudden slip could cause a hand to move into the abrasive belt or disc.
- Use the proper size and type of sanding belt and disc for each operation.
- Turn the machine OFF before removing scrap pieces from the table. Never turn the sander ON before clearing the tables or work surfaces of all objects (tools, wood scraps, etc.) except for the workpiece and related feed or support devices for the operation planned.
- Be certain the abrasive belt runs in the right direction before beginning work. Always have the tracking and tension adjustments set correctly so the belt will not run off the drums.
- Hold work firmly so that it will not be pulled from your hands when finishing on the abrasive belt and against the worktable when finishing against the disc.
- Feed material gradually. Do not force the machine to remove material faster than it was designed to sand.
- Do not attempt to sand pieces too small to safely hold by hand.
- When sanding a large workpiece, make sure it is properly supported at table height.
- Never climb on the Belt and Disc Sander.
- Never leave the machine work area with the power on, or before the machine has come to a complete stop.
- If any part of the belt and disc sander should break or be damaged, or any electrical component fail to perform properly, or if any part is missing, immediately shut off power switch, remove cord from power supply and replace damaged or missing part before resuming operation.
- ALWAYS SUPPORT WORKPIECE WITH "BACKSTOP" OR WORKTABLE.
- MAINTAIN 1/16" MAXIMUM CLEARANCE BETWEEN TABLE AND SANDING BELT OR DISC.
- Use only the motor supplied with your sander.
- FIRE CAUTION:** This machine is not designed for heavy deburring operations. However, when finishing ferrous metals, sparks will

be generated and could cause a fire. To prevent this possibility remove dust collecting apparatus. Remove all traces of wood dust that may have accumulated in and around the machine. Also, the mixing of ferrous and non-ferrous metal dust can create a hazardous environment.

- Use Sander in a well ventilated area.

## SAVE THESE INSTRUCTIONS Grounding

In the event of a malfunction or breakdown, grounding provides a path of least resistance for electric current to reduce the risk of electric shock. This tool is equipped with an electric cord having an equipment grounding conductor and a grounding plug. The plug must be plugged into a matching outlet that is properly installed and grounded in accordance with all local codes and ordinances.

Do not modify the plug provided - if it will not fit the outlet, have the proper outlet installed by a qualified electrician.

This tool is intended for use on a circuit that has an outlet like the one illustrated in sketch A. The tool has a grounding plug that looks like the plug illustrated in sketch A.

A temporary adapter, which looks like the adapter illustrated in sketches B and C, may be used to connect this plug to a 2-pole receptacle as shown in sketch B if a properly grounded outlet is not available. The temporary adapter should be used only until a properly grounded outlet can be installed by a qualified electrician. The green-colored rigid ear lug, and the like, extending from the adapter must be connected to a permanent ground such as a properly grounded outlet box. ADAPTER SHOWN IN FIGURES B & C IS NOT FOR USE IN CANADA.

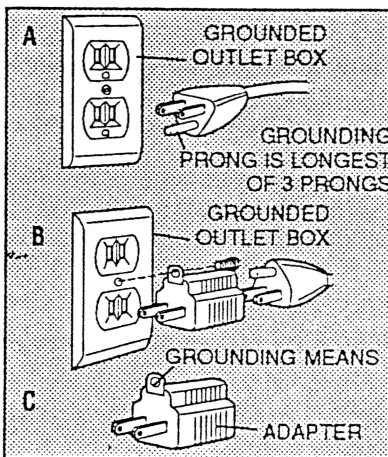

## 120 Volt Operation

Be sure your power supply agrees with the nameplate marking. 120 Volts, "60 Hz" means alternating current (normal 120 volt, 60 Hz house current).

A voltage decrease of more than 10% will cause a loss of power and overheating. All DeWalt tools are factory

tested; if this tool does not operate, check the power supply.

## 208 Volt - 240 Volt Operation

This Belt Sander is factory connected at 120 Volts 60 HZ, single phase. See sketch D.

208 - 240 Volt Operation - The plug supplied must be replaced with the plug shown in Sketch E. It should be used with the proper standard, matching 3-wire grounding receptacle.

Make sure the tool is connected to an outlet having the same configuration as the plug. No adapter is available or should be used with this tool. If the tool must be reconnected for use on a different type of electric circuit, the reconnection should be made by qualified service personnel; and after reconnection, the tool should comply with all local codes and ordinances.

The use of a separate circuit is recommended.

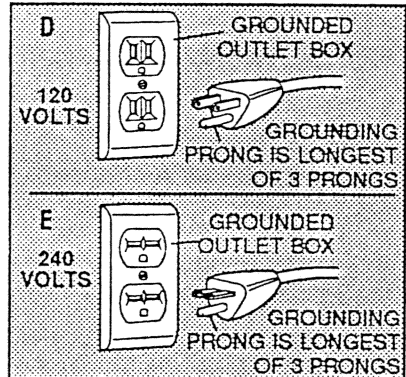

Follow the wiring diagram in Sketch F to reconnect motor from 120 volt operation to 208 - 240 volt operation. Remove motor electrical box cover. Reinstall wire nuts securely after changing leads. After assembling wire nuts, securely tape wire nuts to leads with two full turns of UL approved electrical tape over lead wires and one turn over wire nut in direction to tighten wire nut. Do not disturb ground connection. Position wires inside electrical box and install electrical box cover.

NOTE: Connection for 240 volt requires an additional insulated wire nut (not supplied).

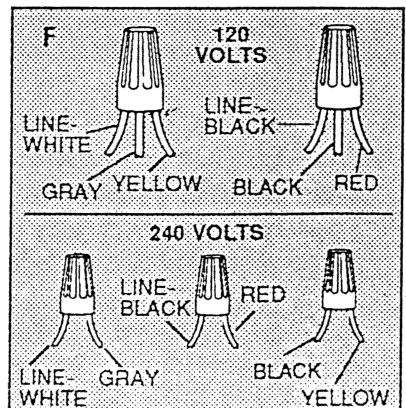

**WARNING:** Motor must be grounded in accordance with local and national electric codes to prevent electrical shock.



# Unpacking

When unpacking be sure to separate all parts from packing material.

There is a protective coating on all unpainted machined surfaces of the sander. Remove this coating with a soft cloth dampened with any type of household solvent. **CAUTION: NEVER USE GASOLINE, NAPHTHA OR HIGHLY VOLATILE SOLVENTS.** After cleaning, to protect the unpainted surfaces apply a coat of good paste wax. **DO NOT APPLY WAX TO BELT TABLE.**

**CAUTION:** For your own safety never connect machine to power outlet until the assembly is completed and you have read and understand the safety and operational instructions.

# Carton Contents

You have purchased a high quality, heavy duty, Belt and Disc Sander. The individual components are heavy. You should have one or two people help you unpack, assemble and move the sander.

Your Sander carton contains the following parts and partial assemblies.

Note: Hardware may not necessarily be grouped in multiple bags. (See Figure 1)

- a. Legs (4)
- b. Rubber Feet (4) Including: 1/4"x1" Bolts (4), 1/4" Flat Washers (4), & 1/4" Nuts (4).
- c. Motor Support Plate (1)  
Includes: Allen Wrenches (2)
- d. Side Panels (2)
- e. Cross Brace (1)
- f. Sander Assembly with V-Belt

- g. Motor with Pulley, Cordset and Switch Box Assembly
- h. Motor Mounting Hardware: 5/16"x 3/4" Hex Head Bolts (4) , 5/16" Flat Washers (8), 5/16" Hex Nuts (4).
- i. V-Belt Guard
- j. Cord Retainer
- k. Side Table Assembly
- l. Edge Sanding Fence & Hardware  
Includes: Spacer, Base, Fence, 3/8"x 1-3/4" Socket Head Bolts (2), 3/8"x 3/4" Socket Head Bolts (2), 3/8" Flat Washers (4).
- m. Table Support Rods (2).
- n. Assembly Hardware Bag for Legstand and Sander Assembly  
Including: 1/4" x 5/8" Hex Head Bolts (28), 1/4" Flat Washers (58), 1/4" Hex Nuts (29), 1/4"x 3/4" Hex Head Bolt (1), 3/8"x1-3/8" Socket Head Bolts(2), 3/8" Nuts(2), 3/8" Flat Washers (4)
- o. Miter Guage

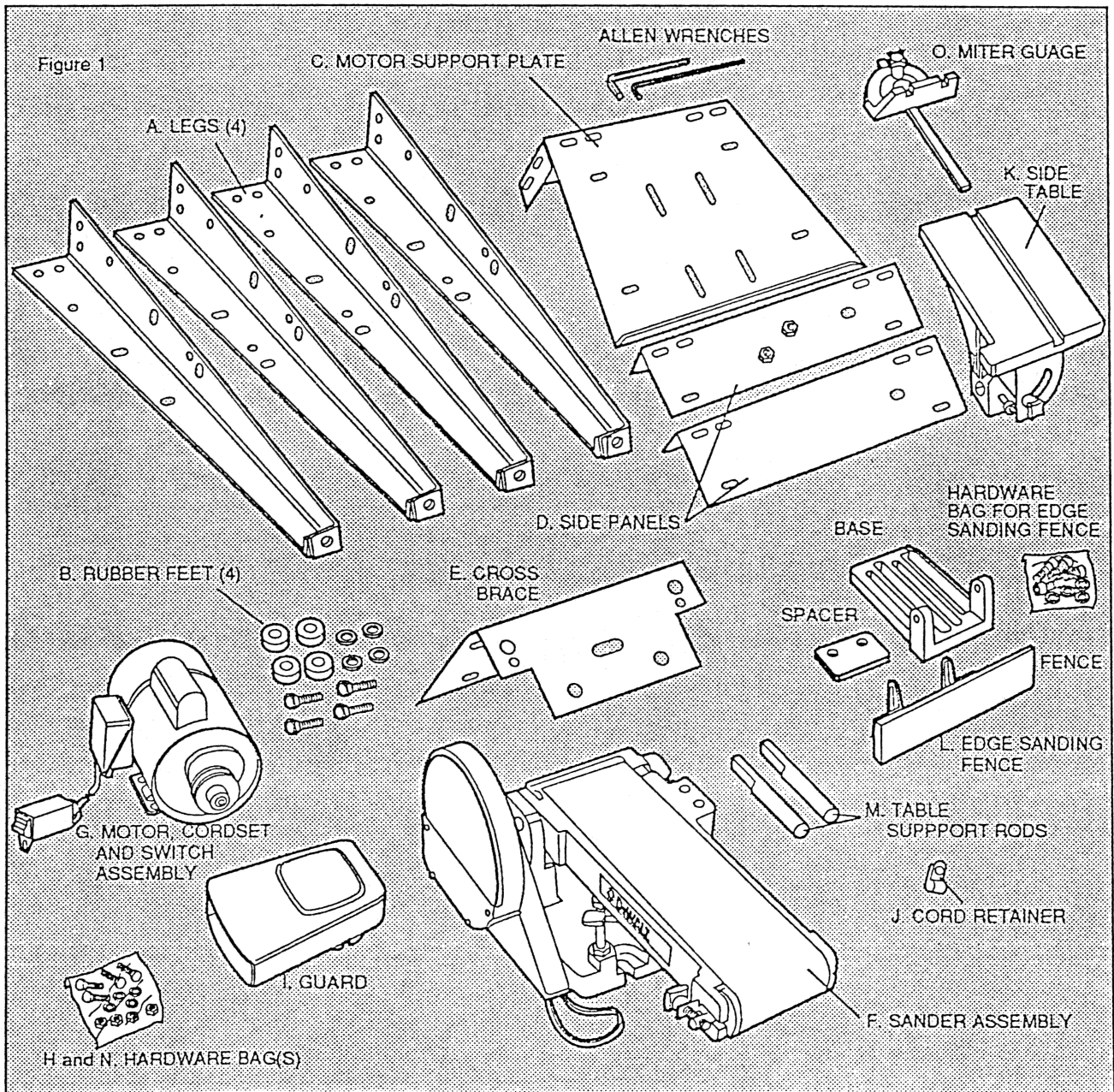

## Assembly

Assemble your Sander carefully. Follow instructions. Study the figures thoroughly.

This tool is designed to be mounted only to the stand provided. **CAUTION:** Mounting of this tool in any other manner than that described in this manual may create a hazardous condition.

Follow the procedure below to properly assemble your Belt and Disc Sander. Use adjustable wrench or metric socket wrench to tighten bolts.

## Assembling The Stand

Begin by laying out the stand parts and the hardware and becoming familiar with the parts and the nomenclature used to describe them. Lay the parts out in a relatively large area.

Assemble the Rubber Feet to the four legs as shown in Figure 2 with 1/4"x 1" Bolts, 1/4" Flat Washers and 1/4" Hex Nuts. Tighten securely.

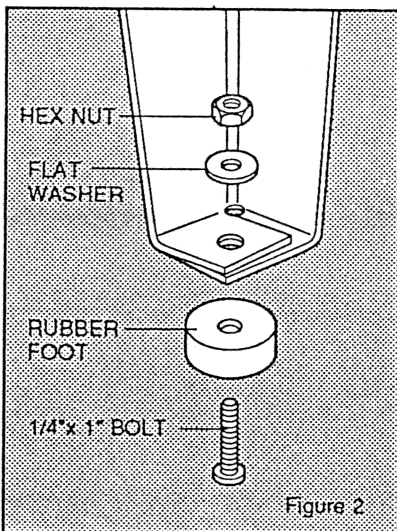

Figure 2

Install 2 Legs to the Motor Support Plate, using 1/4" x 5/8" Hex Head Bolts, Flat Washers & 1/4" Hex Nuts (3 for each Leg). **NOTE:** The orientation of the Legs and Motor Support Plate must be as shown in Figure 3 with Motor Support Plate inside of Legs. Tighten the bolts securely.

Attach the 2 Side Panels to the Legs using 1/4" x 5/8" Hex Head Bolts, Flat Washers & 1/4" Hex Nuts (3 for each Side Panel). **IMPORTANT:** Side Panels must be positioned inside of Legs and Motor Support Plate. See Figure 4.

**Note:** The Side Panels are not identical to each other. One has welded-on nuts. The Side Panel with welded-on nuts must be positioned to the left as shown in Figure 4.

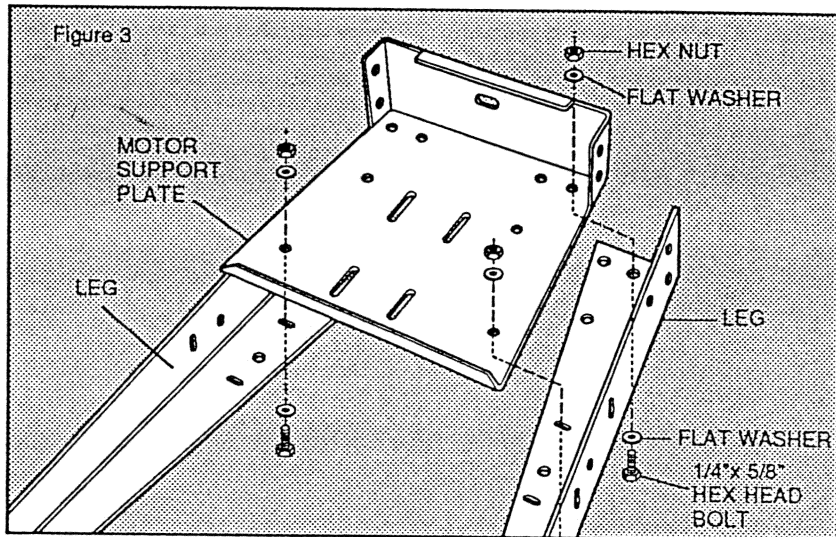

Figure 3

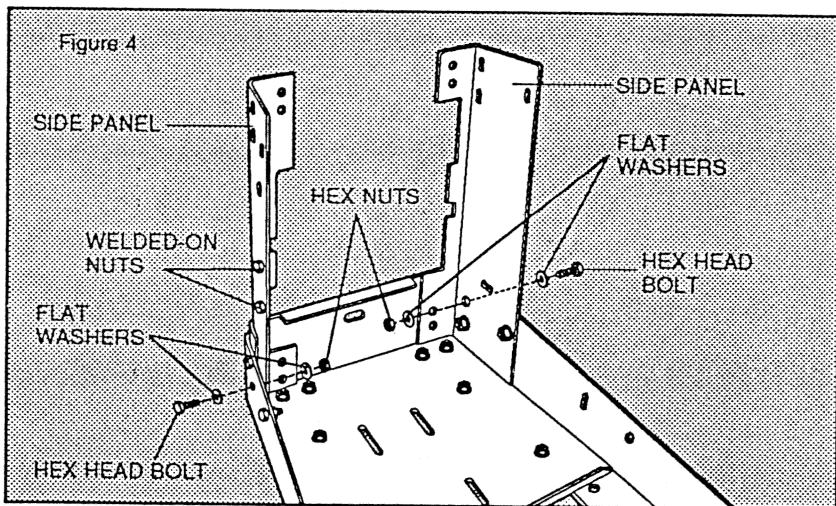

Figure 4

Attach remaining two Legs to the Side Panels using 1/4" x 5/8" Hex Head Bolts, Flat Washers & 1/4" Hex Nuts (3

for each Leg). Legs are positioned outside of Side Panels. See Figure 5.

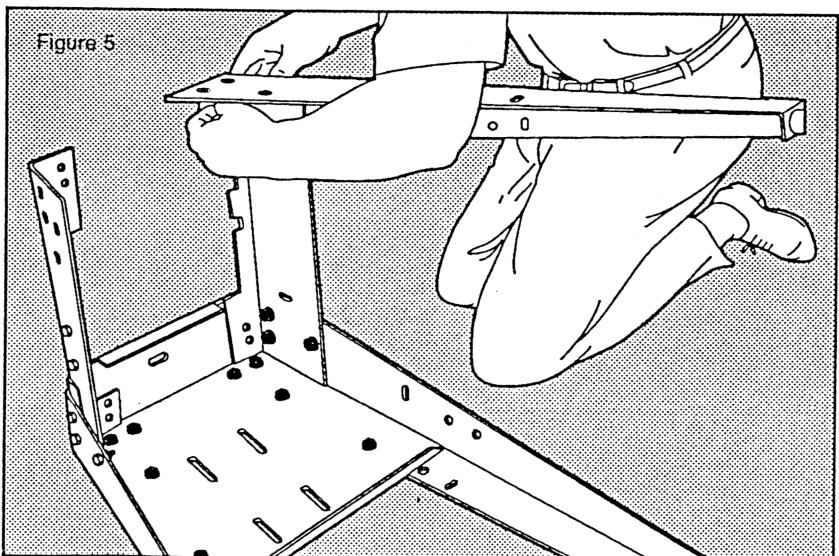
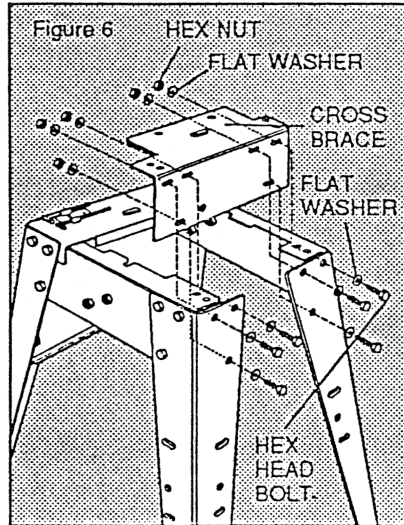

Figure 5

Raise partially assembled stand to its feet on a level surface. Install Cross Brace opposite Motor Support Plate using 1/4" x 5/8" Hex Head Bolts, Flat Washers & 1/4" Hex Nuts (3 for each Leg). The Cross Brace is inserted between the Legs and the end of the Side Panels with top of Cross Brace above the Side Panels. Study Figure 6 carefully for orientation.



Tighten all nuts securely. The stand assembly is now complete.

## Installing The Sander Assembly

In the center of the top face of the Motor Support Plate and the Cross Brace are slots through which the two sander assembly bolts are fastened.

Position the Sander Assembly on the Stand with the Sanding Belt projecting over the Motor Support Plate end of the Stand, as shown in Figure 7. Take care that the "V" Belt projects down below the Sander Assembly to hang free and unobstructed. Align Mounting Slots in Sander assembly with Slots in Stand. Study Figure 7 for proper orientation. Attach Sander Assembly to Stand using 3/8" x 1-3/8" Socket Head Bolts (2), 3/8" Flat Washers (4), and 3/8" Hex Nuts (2). TIGHTEN SECURELY WITH LARGE HEX WRENCH PROVIDED.

## Installing The Motor

TIGHTEN THE TWO SANDER TABLE POSITION CLAMPING BOLTS WITH AN ADJUSTABLE WRENCH SO SANDING TABLE IS CLAMPED IN THE HORIZONTAL POSITION (FIGURE 27). Carefully tip the Stand & Sander Assembly forward so it comes gently to rest with the Sanding Belt touching the floor. See Figure 8.

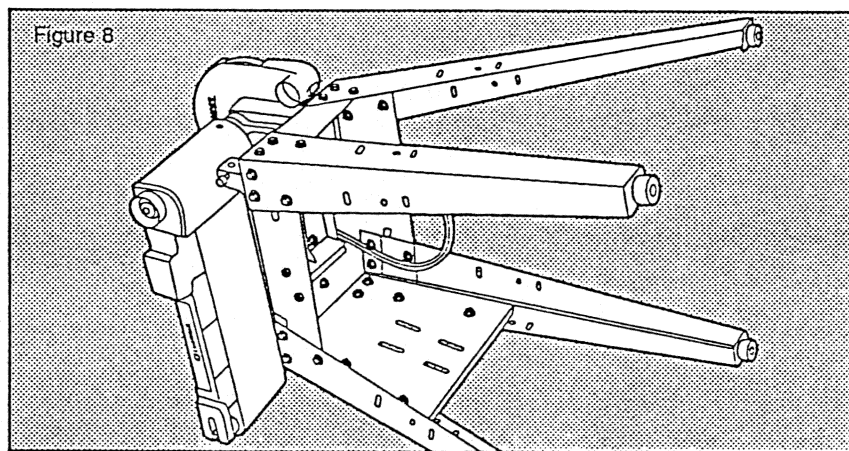
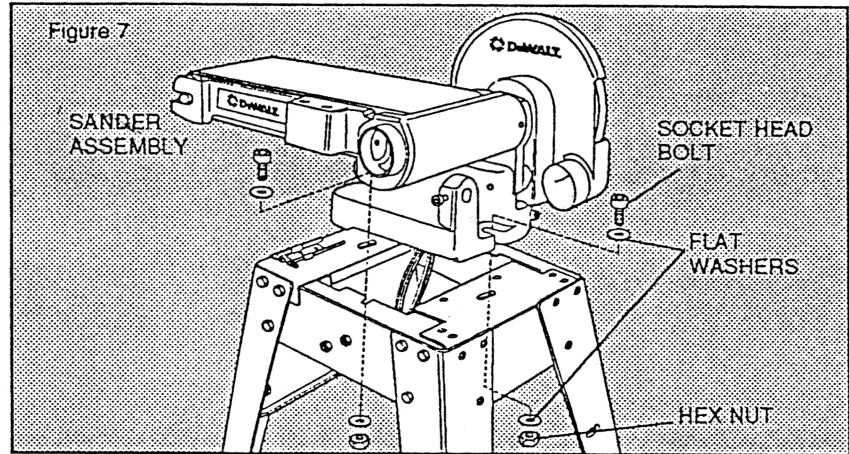

**CAUTION: THIS ASSEMBLY IS VERY HEAVY AND WE RECOMMEND THAT ASSISTANCE OF ANOTHER PERSON BE USED WHEN TIPPING OVER THE SANDER.**

Place Motor on Motor Support Plate. Insert "V" Belt through rectangular end of Belt Guard and around Motor

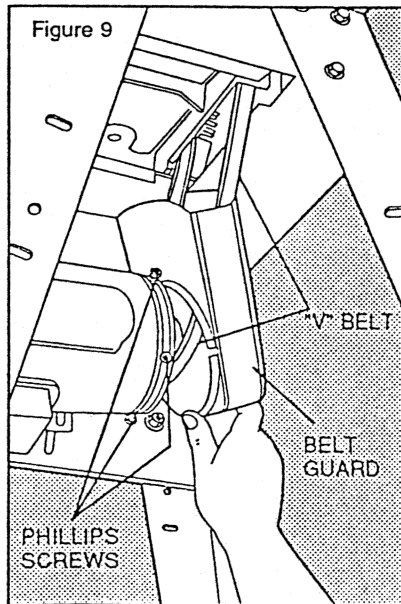

Pulley. Attach Guard to Motor using 3 phillips head screws. See Figure 9 for orientation of Motor, Guard, and Motor Support Plate.

Attach Motor to Motor Support Plate using 5/16" x 3/4" Bolts (4), 5/16" Flat Washers (8) and 5/16" Hex Nuts (4), as shown in Figure 10. Tighten finger-tight only at this time.

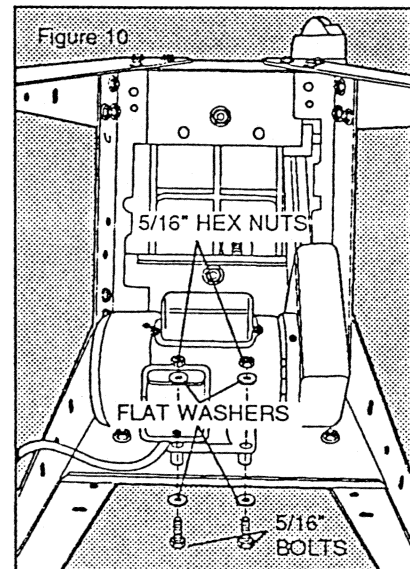



Carefully Stand Sander on its feet. The weight of the motor will cause it to come to rest in position on the Motor Support Plate with proper tension on the "V" Belt. INSPECT ALIGNMENT OF MOTOR & SANDER PULLEYS. IF NECESSARY, ADJUST MOTOR ORIENTATION TO ALIGN PULLEYS. BE SURE MOTOR IS HORIZONTAL. The Motor Bolts should now be tightened securely. See Figure 11.

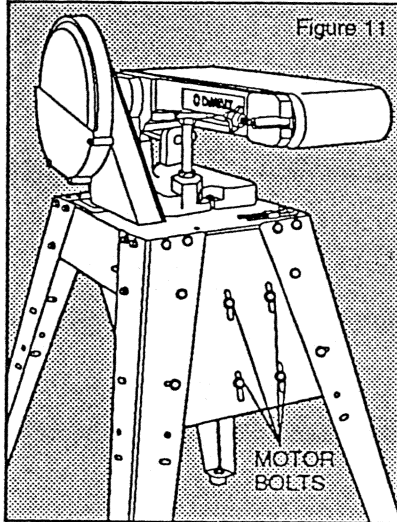

## Installing The Switch

Remove 1/4" x 5/8" Leg Bolt from the Left Front Leg of the Stand. See Figure 12. Mount the Switch to the stand using 1/4" x 5/8" Hex Head Bolt (1), 1/4" x 3/4" Hex Head Bolt (1) Flat Washers (2) & 1/4" Hex Nuts (2). Use the longer bolt to secure the Switch through the hole from which you have removed the leg bolt. This bolt must go through the Switch, Leg, and Side Support. Use the shorter bolt to secure the Switch through the hole in the Motor Support Plate. Tighten securely. See Figure 12.

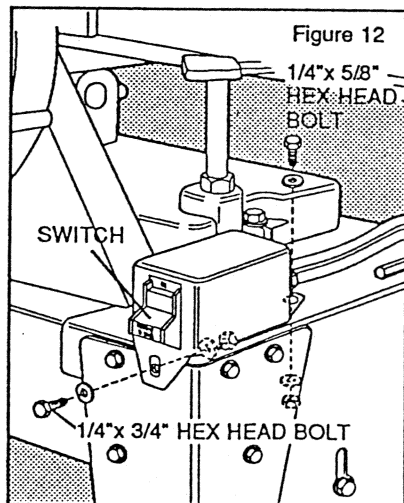

Attach the Cord Retainer to the Right Front Leg using 1/4" x 5/8" Hex Head Bolt, Flat Washer, & 1/4" Hex Nut. See Figure 13. Allow slack in cord on both sides of cord retainer.

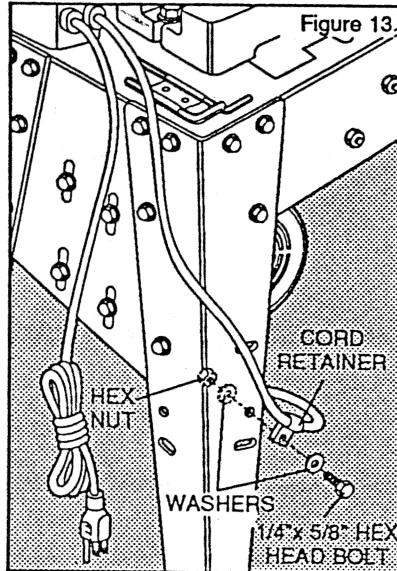

## Install Table Support Rods

Install the two Table Support Rods to the Sander Assembly. Insert one Rod into the hole under the sanding disc and the other rod into the hole under the back of the Sanding belt. Insert each rod so it is flush to the back of the casting and not deeper. See Figure 14.

NOTE: The Rods must be inserted so the round end enters the hole. The flat must be positioned so that the flat surface is vertical and to the left as you face the Sander. Use the large Allen Wrench provided to tighten the Socket Head Bolts.

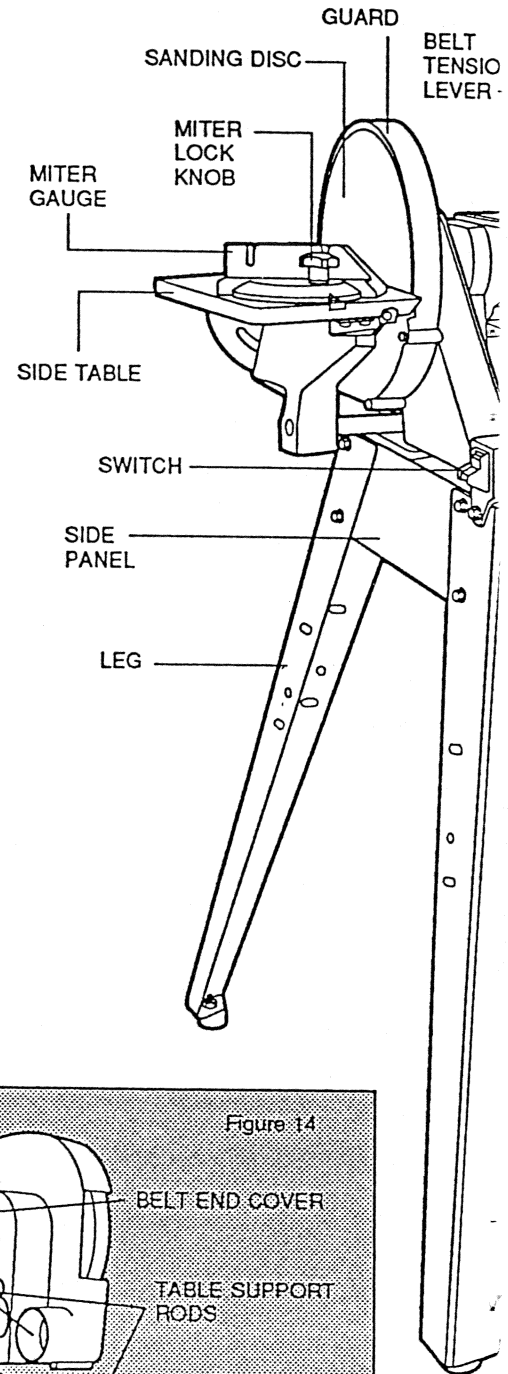
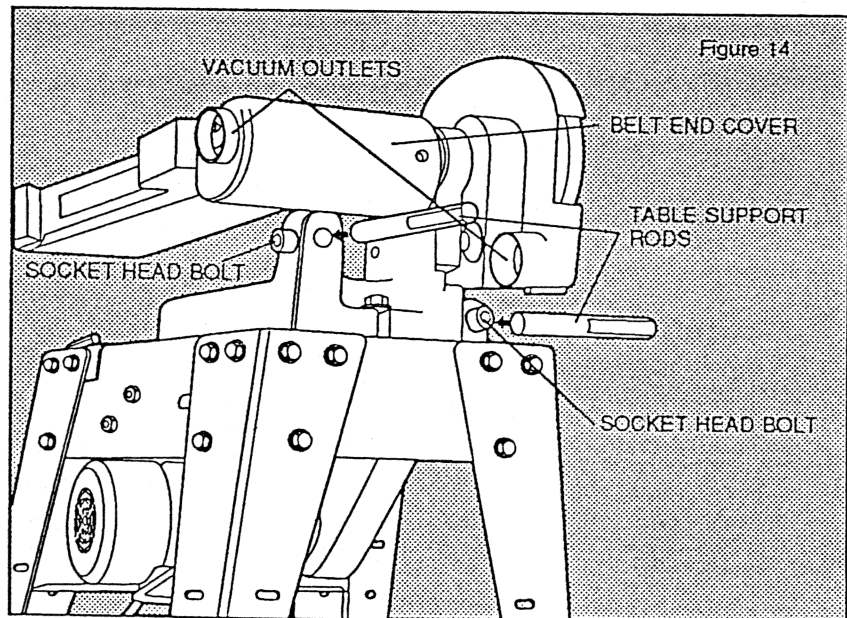

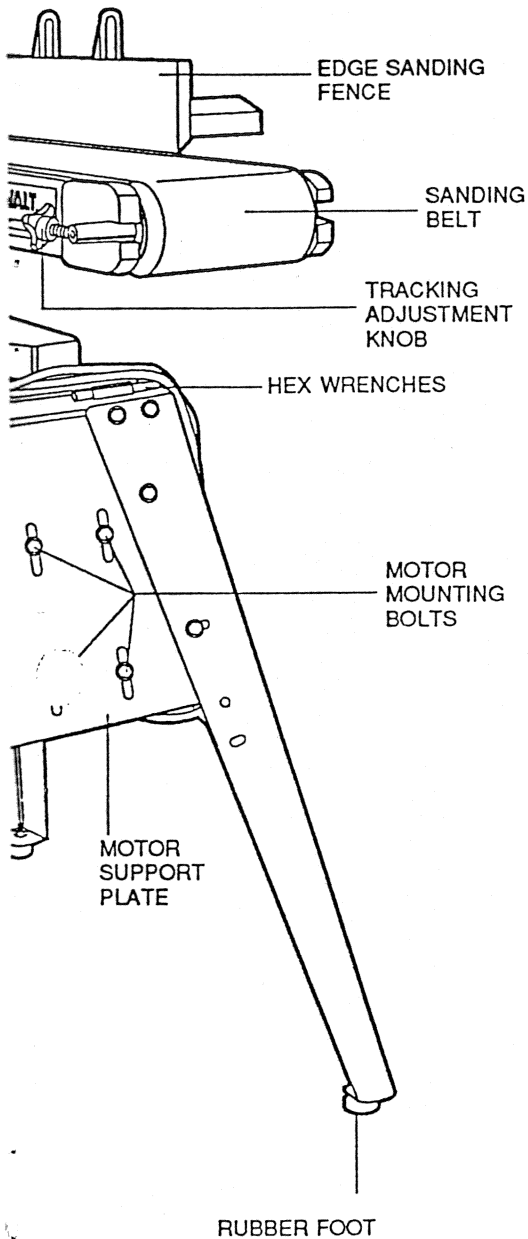

## Adjusting Sanding Disc

The position of the Sanding Disc must be inspected & adjusted, if necessary, before Side Table Installation. Adjust Disc Face to protrude 1/16" past Disc Guard. Use long Allen Wrench provided to loosen and tighten Disc Retaining Set Screw. See Figure 15.

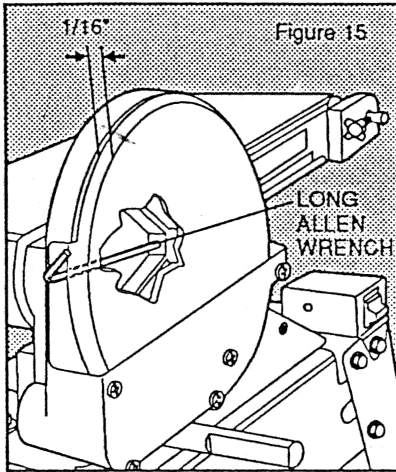

## Install Side Table

The Side Table can be mounted on the Table Rod extending from beneath the sanding disc as shown in Figure 16. It can also be mounted on the Table Rod extending from beneath the sanding belt, as shown in Figure 17. After mounting the Table tighten the Clamping Bolt against the Rod using the wrench provided. Keep gap of 1/16" from Side Table to Sanding Disc.

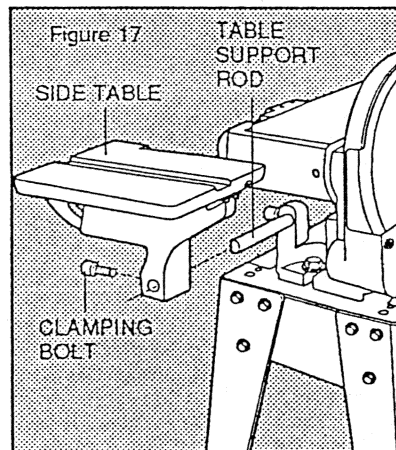
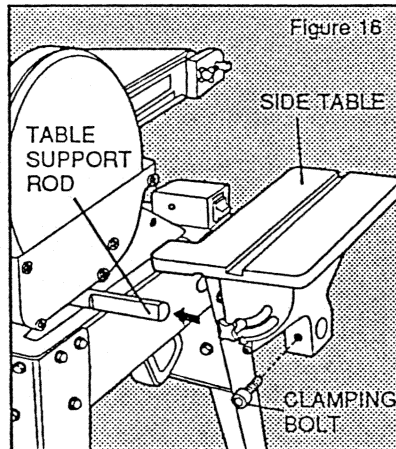

## Install Edge Sanding Fence

The Edge Sanding Fence is an innovative device which should prove to be very useful. First install the Spacer Plate with the wide side toward belt, as shown in Figure 18. NEVER INSTALL EDGE SANDING FENCE WITHOUT SPACER.

Attach Edge Sanding Base with 3/8" x 1-3/4" Hex Head Bolts (2), and 3/8" Flat Washers (2) to sanding table. See Figure 18. Use Large Hex Wrench provided.

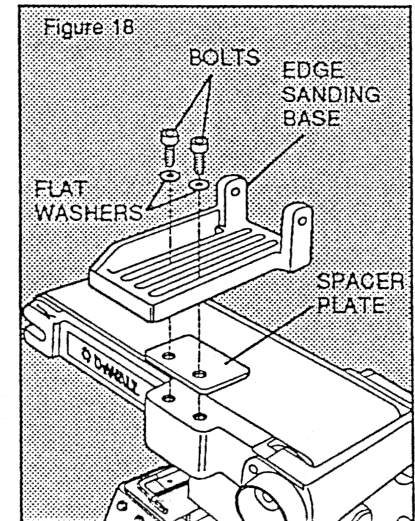

Attach Edge Sanding Fence to Edge Sanding Base with 3/8" x 3/4" Hex Head Bolts (2) and 3/8" Flat Washers, as shown in Figure 19. Use Large Hex Wrench provided.

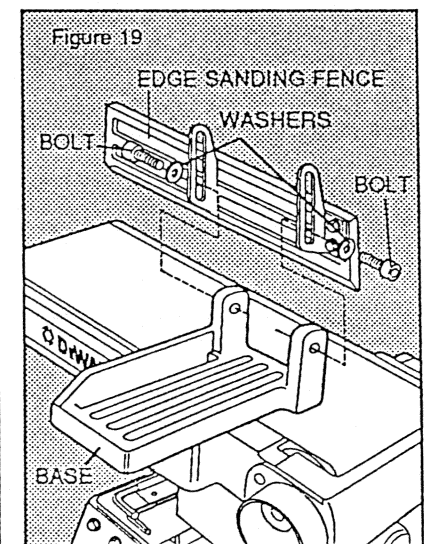



# Adjustments

WHEN MAKING ANY ADJUSTMENTS:

1. ALWAYS UNPLUG THE TOOL
2. TIGHTEN BOLTS AFTER MAKING ADJUSTMENTS.
3. MOVE BELT BY HAND TO CHECK FOR BELT AND DISC CLEARANCE TO SIDE TABLE AND FENCE.

**"V" BELT TENSION ADJUSTMENT:** The "V" drive belt should deflect about one inch at the midpoint between the pulleys with finger pressure. To adjust the belt tension loosen the 4 bolts which fasten the motor to the stand. Slide the motor in the slots on the motor base until the correct tension is achieved, then tighten the bolts firmly. See Figure 20.

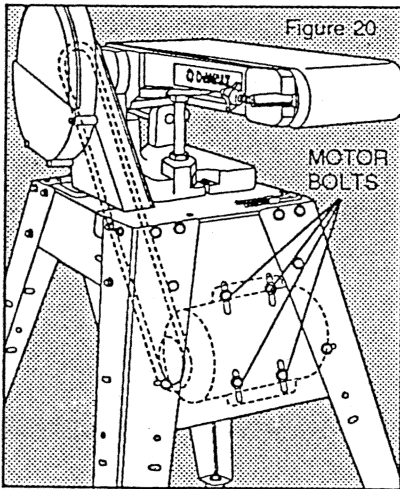

Figure 20

**SANDING BELT TENSION:** The sanding belt has been designed with an automatic spring tension system. Therefore, the sanding belt never requires tension adjustment.

**BELT TRACKING ADJUSTMENT:** With the sander running, turn the Tracking Adjustment Knob until the Belt is centered on both pulleys. See Figures 21 & 22.

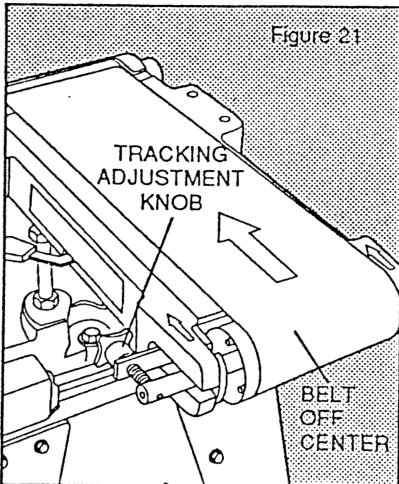
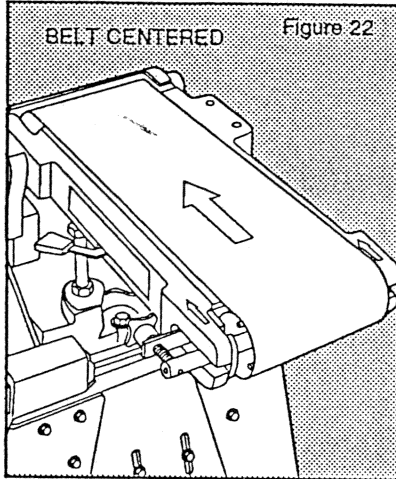

Figure 21



BELT CENTERED Figure 22

## Operation

Your sander is designed to be used in a number of different sanding operations. You can sand horizontally or vertically with the sanding belt and on either side of it or on the rounded end. The Edge Sanding Fence allows for a great deal of flexibility in the use of the Sanding Belt. In addition, of course, is the sanding disc with an adjustable table. Each of these operations will be briefly discussed in this section.

### EDGE SANDING FENCE:

The Edge Sanding fence can be positioned for through-sanding as shown in Figure 23. Note: the Fence can be adjusted to any position across the Belt.

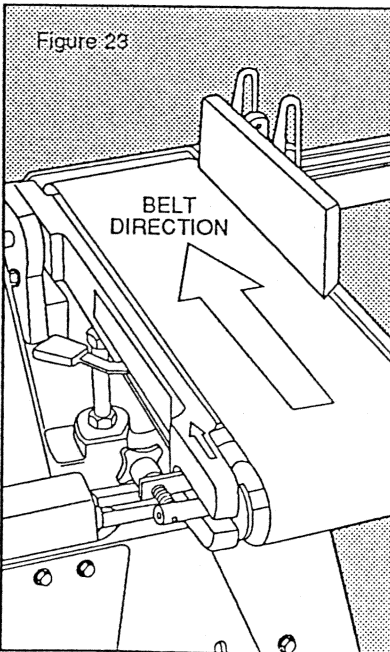

Figure 23

The Edge Sanding fence can be positioned as an End Stop. It can be set in the Short End Stop Position, (Figure 24) or in the Long End Stop Position

(Figure 25). To change from Short to Long End Stop Position simply remove Bolt indicated in Figure 24, rotate the Base, and reinstall Bolt. See Illustrations 24 and 25 below.

NEVER USE EDGE SANDING FENCE WITH BOLTS LOOSE.

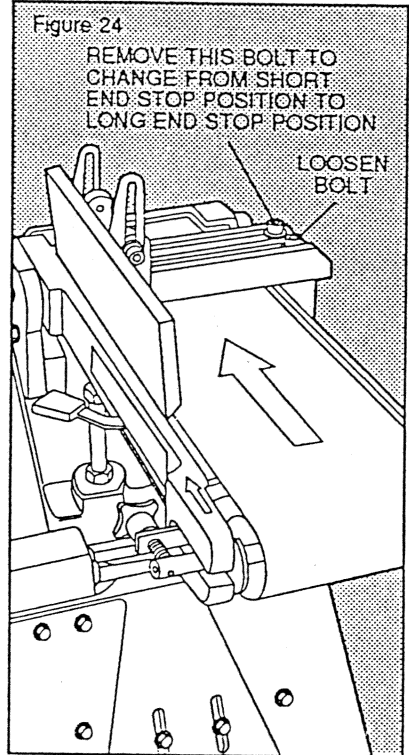

Figure 24

REMOVE THIS BOLT TO CHANGE FROM SHORT END STOP POSITION TO LONG END STOP POSITION

LOOSEN BOLT

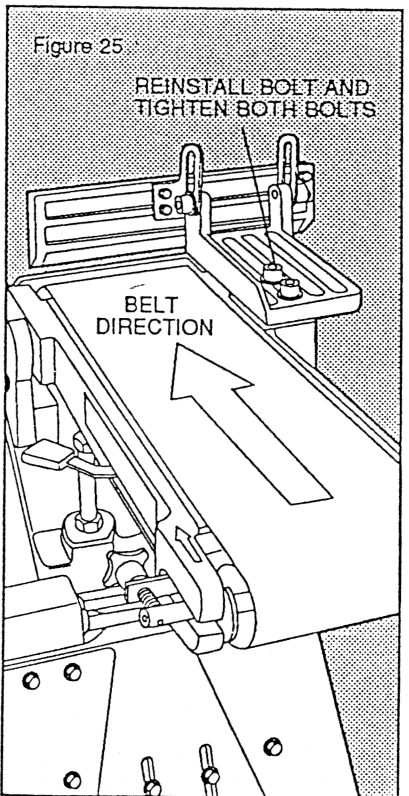
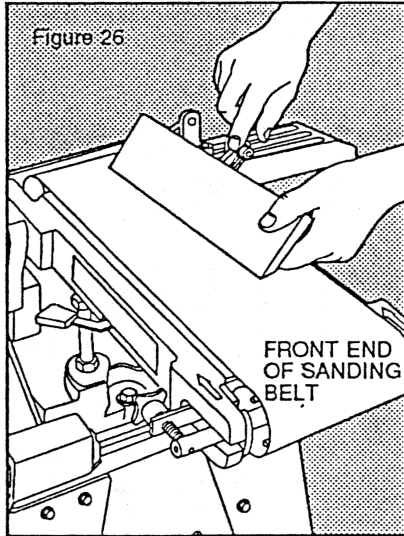

Figure 25

REINSTALL BOLT AND TIGHTEN BOTH BOLTS

BELT DIRECTION

The Edge Sanding fence can be used for sanding beveled edges. Simply position the Edge Sanding Fence for through sanding and adjust the fence to any angle desired. See Figure 26. **IMPORTANT: ALWAYS KEEP A GAP OF 1/16" BETWEEN THE SANDING BELT AND THE SANDING FENCE, AND ALWAYS TIGHTEN THE BEVEL ADJUSTMENT BOLTS SECURELY SO FENCE WILL NOT MOVE WHILE IN USE.**



**INSIDE CONTOUR SANDING:** Inside contours of 1-3/4" and greater radii can be sanded on the pulley at front end of the Sanding Belt. For best results, start at one end of the radius and move the piece up and down following the contour. At the same time, move the piece slowly across the width of the pulley. A little practice on scrap material will prove quite helpful. See Figure 26.

**OUTSIDE CONTOUR SANDING:** For Sanding outside contours the sanding belt must be placed in the vertical position. Loosen the two Table Position Clamping Screws, shown in Figure 27, with an adjustable wrench.

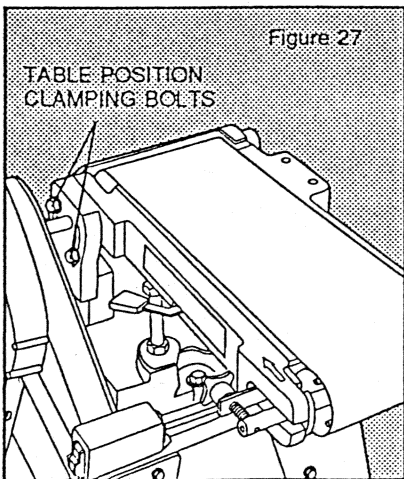

Lift the front end of the Sanding Belt Table and raise it up as far as it will go. Tighten the two table position clamping bolts firmly. See Figures 27 & 28.

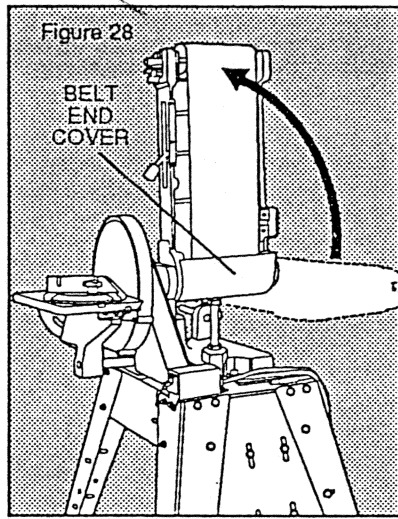

**NOTE:** The Sanding Belt Table is designed to be used in either the horizontal or vertical position. Any position between these two may be hazardous.

Sand outside contours on the unsupported side of the sanding belt.

**SANDING DISC:** The Sanding Disc must always be used with the sanding table in place. Sand only on the part of the disc that is rotating down, as shown in Figure 29.

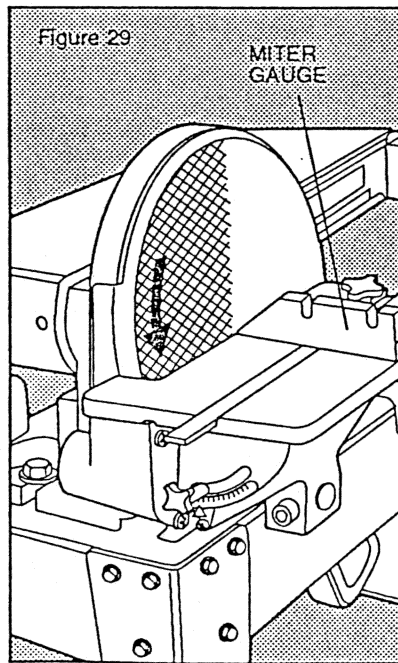

Use the miter gauge to help hold the work piece firmly for best results.

**WORK TABLE AND MITER GAUGE:** The Work Table mounts to either of the table Support Rods. Simply install the Table to the Rod by sliding the hole in the Table Bracket over the Rod and tightening the clamping bolt to the Rod with the large Hex Wrench provided. The Table can be used with the disc or with the sanding belt at the back end of the sanding belt. The table tilts from 0° (horizontal) to 45° bevel by loosening Table Miter Scale Clamp Knob. See Figure 30.

**NOTE:** The gap between the work table and the belt or disc must be maintained at 1/16". The table should not touch the sanding surface. The table tilts and has a handy miter gauge for bevel sanding.

The separate miter gauge fits into the slot in the work table and can be very helpful in holding the workpiece and controlling its movement along the sanding surface. The gauge is adjustable by loosening the large knob on top and selecting the desired angle. Tighten the knob to hold the angle. See Figure 30.

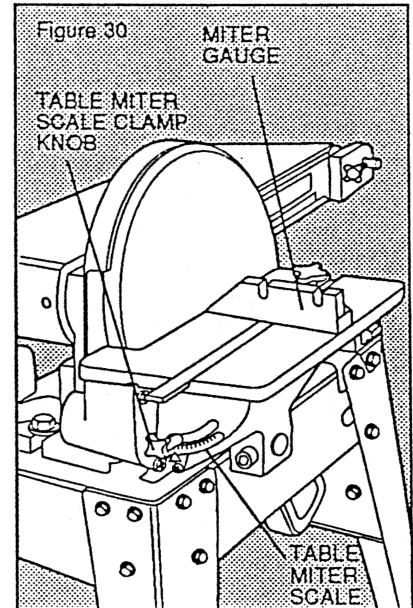

## Vacuum Attachment

Your DeWalt Belt Sander is equipped with two vacuum exhaust ports designed to accept a standard 2-1/2" vacuum connection. We recommend that you do not use a "Y" connection to apply vacuum to both the Sanding Belt and the Sanding Disc vacuum outlets. This would result in significant vacuum loss in both areas. For best dust pick-up use one hose and move it from disc connection to belt connection as needed.

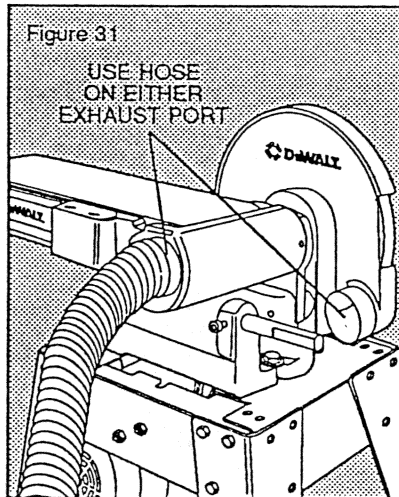

**NOTE:** With the Sanding Belt in vertical position and the Side Table positioned at the Sanding Belt, it will be necessary to remove the Belt End Cover (vacuum attachment) in order to tilt the side table to 45°. See Figure 32.

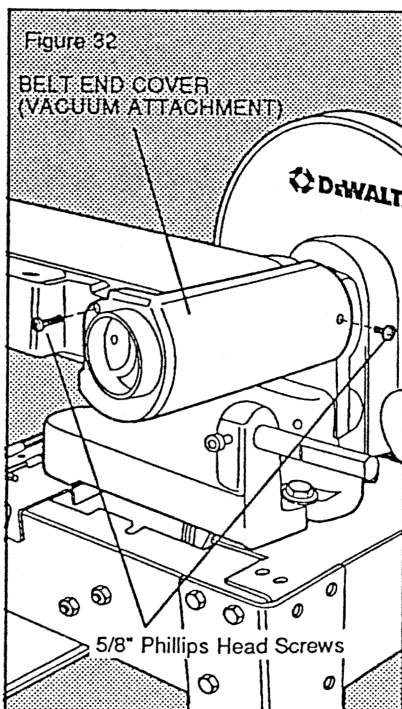

## Storage of Edge Sanding Fence

For your convenience in storing the Edge Sanding Fence, DeWalt has provided two nuts welded onto the Side Support. Using the same two Socket Head Bolts that mount the Fence to the Belt Table, hang the Fence assembly and Spacer by inserting the Bolts through the bottom of the mounting slots. The bottom of the End Stop Base should be facing outward. Finger tighten the two bolts in the two welded nuts. See Figure 33.

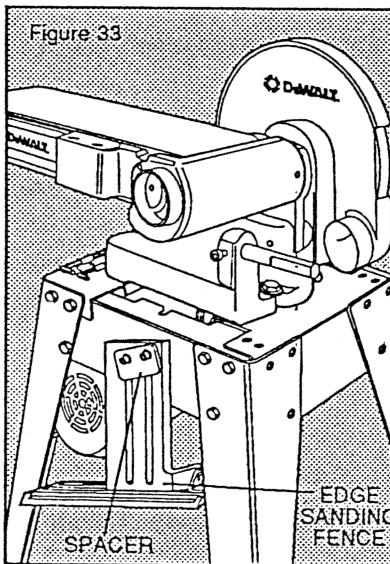

## Storage of Miter Gauge

The Miter Gauge can be easily stored on the tool by inserting the guide down between the Belt Sander and the Side Support. See Figure 34.

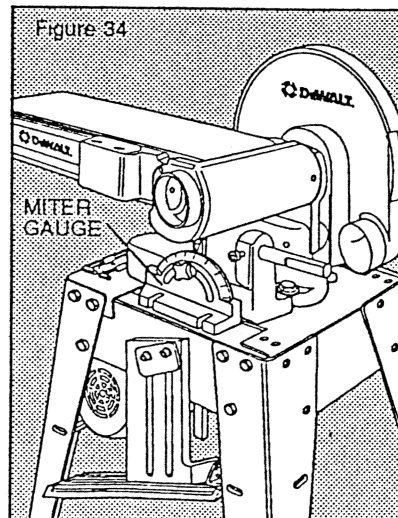

## Changing Sanding Belt

**TURN OFF AND UNPLUG SANDER BEFORE CHANGING THE SANDING BELT.**

The replacement of a worn sanding belt is an easy operation. First, remove the Edge Fence Assembly. Next, the Belt End Cover must be removed. It is held in place with two 5/8" phillips head screws. See Figure 32. Pull the Belt Tension Lever to the forward position. This releases belt tension so the Belt can be removed.

After removing the worn belt, replace with a new belt. **ALWAYS CHECK SANDING BELT FOR PROPER DIRECTION BEFORE INSTALLING NEW BELT. ARROW PRINTED INSIDE BELT WILL SHOW PROPER DIRECTION AND SHOULD AGREE WITH ARROW CAST ON SIDES OF BELT TABLE.** Push Belt Tension Lever to the rear position, as far as it will go. This puts proper tension on the belt. Reattach Belt End Cover and Edge Sanding Fence. See Figures 35, & 18.

Reattach Belt End Cover. See Figure 32.

**Note:** It may be necessary to readjust belt tracking after belt replacement. See **BELT TRACKING ADJUSTMENT**, Figure 21.

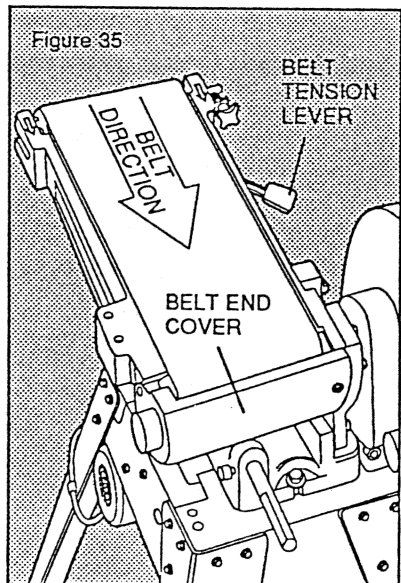

## Important

To assure product **SAFETY** and **RELIABILITY**, repairs, maintenance and adjustment should be performed by Black & Decker Service Centers or other qualified service organizations, always using Black & Decker replacement parts.

## Recommended Accessories

The accessories listed in this manual are available at extra cost from your local dealer or Black & Decker Service Center. A complete listing of service centers is included on the owner's registration card packed with your tool.

If you need assistance in locating any accessory, please contact: Black & Decker (U.S.) Inc., User Services Department, 626 Hanover Pike, P.O. Box 618, Hampstead, MD 21074-0618. **THE USE OF ANY OTHER ACCESSORIES OR ATTACHMENTS MIGHT BE HAZARDOUS.**

	Black & Decker Cat. No.	Size	Grit
Closed Coat Sanding Disc	54436	10"	40
Closed Coat Sanding Disc	54437	10"	80
Closed Coat Sanding Disc	54438	10"	120
Closed Coat Sanding Belt	58413	6" x 48"	40
Closed Coat Sanding Belt	58414	6" x 48"	80
Closed Coat Sanding Belt	58415	6" x 48"	120

## Extension Cords

Tools that have 3-wire cords requiring grounding must only be used with extension cords that have 3-prong grounding type plugs and 3-pole receptacles. Make sure which construction your tool is before choosing an extension cord. Only round jacketed extension cords should be used, and we recommend that they be listed by Underwriters Laboratories. (U.L.) (C.S.A. in Canada.) If the extension will be used outside, the cord must be suitable for outdoor use. Any cord marked as outdoor can also be used for indoor work. The letters "WA" on the cord jacket indicate that the cord is suitable for outdoor use.

An extension cord must have adequate wire size (AWG or American Wire Gauge) for safety, and to prevent loss of power and overheating. The smaller the gauge number of the wire, the greater the capacity of the cable, that is 16 gauge has more capacity than 18 gauge. When using more than one extension to make up the total length, be sure each individual extension contains at least the minimum wire size.

To determine the minimum wire size required, refer to the chart below.

NAMEPLATE RATING - AMPS	CHART FOR MINIMUM WIRE SIZE (AWG) OF EXTENSION CORDS							
	TOTAL EXTENSION CORD LENGTH - FEET							
	25	50	75	100	125	150	175	200
0 - 10.0	18	18	16	16	14	14	12	12
10.1 - 13.0	16	16	14	14	14	12	12	12
13.1 - 15.0	14	14	12	12	12	12	12	—

Before using an extension cord, inspect it for loose or exposed wires, damaged insulation, and defective fittings. Make any needed repairs or replace the cord if necessary. Black & Decker has extension cords available that are U.L. (C.S.A. in Canada) listed for outdoor use.

## HINTS TO BETTER SANDING

1. Read and understand this manual thoroughly. Follow correct assembly procedures. Give careful consideration to safety rules. **NOTE:** Maximum gap is 1/16" between the work table and the belt or disc.
2. Hold the work firmly so that it will not be pulled from your hands.
3. Sand with the direction of the grain where possible.
4. Have different grit belts and discs available—Use rough sanding abrasives for heavy stock removal and repeat with finer grits for finer finish, consult "Recommended Accessories".
5. Move the work—holding it too long in one spot will heat up the belt and the work piece. Sometimes it can heat up enough to shorten belt life and burn the work.
6. Feed the work with light pressure. Let the grit cut and remove the stock. A heavy feed will sometimes load up the belt with dust and decrease its cutting efficiency. Heavy feed also causes excess friction and drag which can result in motor fatigue, belt wear, possible kickback, and overall poor results.

## Maintenance

**WARNING: FOR YOUR OWN SAFETY, TURN SWITCH "OFF" AND REMOVE PLUG FROM POWER SOURCE OUTLET BEFORE ADJUSTING OR MAINTAINING YOUR BELT SANDER.**

If power cord is worn or cut, or damaged in any way, have it replaced immediately.

Frequently blow out any dust that may accumulate around the motor.

A coat of automobile-type wax applied to the work table will help prevent rust and make it a little easier to feed the work while finishing. **DO NOT APPLY WAX TO THE BELT TABLE** because the belt could pick up wax and deposit it on the pulleys, causing the belt to slip.

**WARNING: DO NOT ATTACH A VACUUM CLEANING DEVICE WHEN FINISHING IRON OR STEEL. THE SPARKS COULD IGNITE THE DEBRIS AND CAUSE A FIRE.**

**LUBRICATION:** The drive pulley bearings and the idler pulley bearings on the motor bearings are **SEALED BALL BEARINGS**—they require no further lubrication.

## Trouble Shooting

**CAUTION: FOR YOUR OWN SAFETY TURN SWITCH "OFF" AND ALWAYS REMOVE PLUG FROM POWER SOURCE OUTLET BEFORE TROUBLESHOOTING.**

### GENERAL

PROBLEM	PROBABLE CAUSE	SOLUTION
Machine slows down when sanding	<ol style="list-style-type: none"> <li>1. V-Belt too loose</li> <li>2. Applying too much pressure to work piece</li> <li>3. Too little tension on abrasive belt</li> </ol>	<ol style="list-style-type: none"> <li>1. Increase belt tension. See Pages 8 &amp; 10.</li> <li>2. Ease up on pressure</li> <li>3. Check belt tension lever.</li> </ol>
Abrasive Belt Slips	<ol style="list-style-type: none"> <li>1. Not enough tension</li> </ol>	<ol style="list-style-type: none"> <li>1. Check belt tension lever</li> <li>2. Belt too long</li> </ol>
Abrasive Belt runs off pulleys	<ol style="list-style-type: none"> <li>1. Improper Tracking</li> <li>2. Not enough tension</li> </ol>	<ol style="list-style-type: none"> <li>1. Adjust tracking. See Adjustment Section, Belt Tracking</li> <li>2. Check belt tension lever</li> </ol>
Wood burns while sanding	<ol style="list-style-type: none"> <li>1. Abrasive disc or belt is glazed with sap or worn</li> </ol>	<ol style="list-style-type: none"> <li>1. Replace disc or belt</li> </ol>

### MOTOR

**CAUTION: ALWAYS UNPLUG UNIT WHEN CHECKING ELECTRICAL CONNECTIONS.**

PROBLEM	PROBABLE CAUSE	SOLUTION
Motor will not run	<ol style="list-style-type: none"> <li>1. Circuit breaker (fuse) open</li> <li>2. Low voltage</li> <li>3. On-off switch</li> <li>4. Loose or broken connection in motor compartment or switch terminals</li> </ol>	<ol style="list-style-type: none"> <li>1. Reset circuit breaker or replace fuse</li> <li>2. Check outlet for proper voltage</li> <li>3. Replace switch</li> <li>4. Check all connections in motor compartment and switch</li> </ol>
Motor will not run and/or circuit breakers (fuses) "blow"	<ol style="list-style-type: none"> <li>1. Power line overloaded with lights, appliances and other motors</li> <li>2. Short circuit in line cord or plug</li> <li>3. Short circuit in junction box or loose connections</li> </ol>	<ol style="list-style-type: none"> <li>1. Reduce line load</li> <li>2. Inspect cord and plug for damaged insulation or shorted wires</li> <li>3. Check all connections in motor compartment and switch</li> </ol>
Motor starts slowly, fails to develop full power or speed and/or stalls easily	<ol style="list-style-type: none"> <li>1. Power line overloaded with lights, appliances and other motors</li> <li>2. Voltage too low</li> <li>3. Undersize wire circuit (extension cord) too long</li> <li>4. Incorrect circuit breaker (fuse) in line</li> <li>5. V Belt too tight</li> </ol>	<ol style="list-style-type: none"> <li>1. Reduce line load</li> <li>2. Check and correct if necessary any low line voltage condition</li> <li>3. Increase wire size and/or reduce length of wiring</li> <li>4. Replace fuses or circuit breakers with proper capacity units</li> <li>5. See Page 8</li> </ol>
Motor overheated	<ol style="list-style-type: none"> <li>1. Improper cooling due to restricted air circulation through motor usually caused by buildup of sawdust, etc.</li> </ol>	<ol style="list-style-type: none"> <li>1. Clean out sawdust to provide air circulation through motor</li> </ol>



**NOTES**

## Commercial/Industrial Use Warranty

Black & Decker (U.S.) Inc. warrants this product for one year from date of purchase. We will repair without charge, any defects due to faulty material or workmanship. Please return the complete unit, transportation prepaid, to any Black & Decker Service Center or Authorized Service Station, listed under "Tools Electric" in the yellow pages. This warranty does not apply to accessories or damage caused where repairs have been made or attempted by others.

### Important!

To assure product SAFETY and RELIABILITY, repairs, maintenance and adjustment (excluding maintenance described in this manual) should be performed by BLACK & DECKER Service Centers or other qualified service organizations, always using BLACK & DECKER replacement parts.

Like most Black & Decker products your tool is listed by Underwriters Laboratories to insure that it meets stringent safety requirements.



This symbol on the nameplate means the product is listed by Underwriters Laboratories, Inc.



See 'Tools-Electric'  
— Yellow Pages —  
for Service & Sales



Division of:

BLACK & DECKER (U.S.) INC., U.S. Power Tools Group, 10 North Park Drive, P.O. 798, Hunt Valley, MD 21030-0798 U.S.A.

Form No. 741999

(Sep. 88) ©1988 Printed in Taiwan