

Black & Decker (U.S.) Inc. • 701 East Joppa Road, Towson, Maryland 21286
Printed in U.S.A. (DEC95-CD-1) Form No. 154574 Copyright © 1995

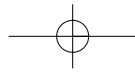



Instruction Manual

2610-220 Spade Handle Drills

Getting the most out of your tool.

Please take time to read this manual and pay particular attention to the safety rules we've provided for your protection. If you have any questions about your tool please call:

1-800-9-BD TOOL
(1-800-923-8665)

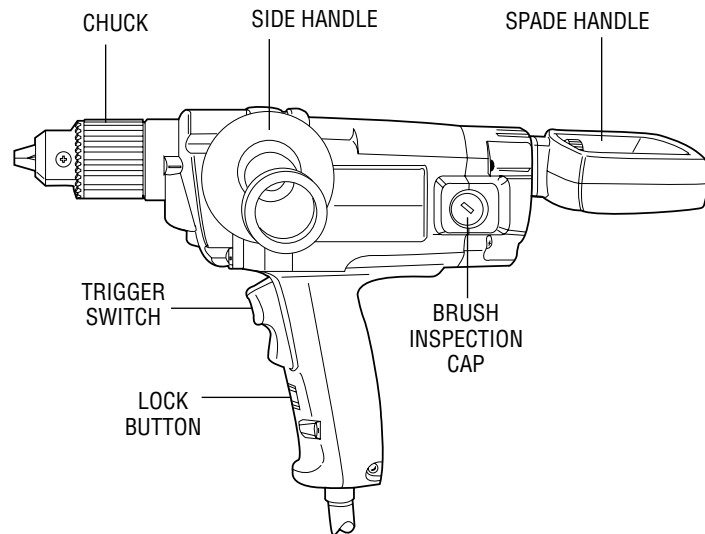

2610-220 1/2" (13mm) Spade Handle Drill with 220 volt plug

IMPORTANT SAFETY INSTRUCTIONS

WARNING: When using electric tools, basic safety precautions should always be followed to reduce risk of fire, electric shock, and personal injury, including the following:

READ ALL INSTRUCTIONS

2610-220



Double Insulation

Double insulated tools are constructed throughout with two separate layers of electrical insulation or one double thickness of insulation between you and the tool's electrical system. Tools built with this insulation system are not intended to be grounded. As a result, your tool is equipped with a two prong plug which permits you to use extension cords without concern for maintaining a ground connection.

NOTE: Double insulation does not take the place of normal safety precautions when operating this tool. The insulation system is for added protection against injury resulting from a possible electrical insulation failure within the tool.

CAUTION: WHEN SERVICING USE ONLY IDENTICAL REPLACEMENT PARTS. Repair or replace damaged cords.

Safety Instructions For All Tools

- **KEEP WORK AREA CLEAN.** Cluttered areas and benches invite injuries.
- **CONSIDER WORK AREA ENVIRONMENT.** Don't expose power tools to rain. Don't use power tools in damp or wet locations. Keep work area well lit. Do not use tool in presence of flammable liquids or gases.
- **GUARD AGAINST ELECTRIC SHOCK.** Prevent body contact with grounded surfaces. For example; pipes, radiators, ranges, and refrigerator enclosures.
- **KEEP CHILDREN AWAY.** Do not let visitors contact tool or extension cord. All visitors should be kept away from work area.
- **STORE IDLE TOOLS.** When not in use, tools should be stored in dry, and high or locked-up place — out of reach of children.
- **DON'T FORCE TOOL.** It will do the job better and safer at the rate for which it was intended.
- **USE RIGHT TOOL.** Don't force small tool or attachment to do the job of a heavy-duty tool. Don't use tool for purpose not intended.
- **DRESS PROPERLY.** Do not wear loose clothing or jewelry. They can be caught in moving parts. Rubber gloves and non-skid footwear are recommended when working outdoors. Wear protective hair covering to contain long hair.
- **USE SAFETY GLASSES.** Also use face or dust mask if operation is dusty.
- **DON'T ABUSE CORD.** Never carry tool by cord or yank it to disconnect from receptacle. Keep cord from heat, oil, and sharp edges.
- **SECURE WORK.** Use clamps or a vise to hold work. It's safer than using your hand and it frees both hands to operate tool.
- **DON'T OVERREACH.** Keep proper footing and balance at all times.
- **MAINTAIN TOOLS WITH CARE.** Keep tools sharp and clean for better and safer performance. Follow instructions for lubricating and changing accessories. Inspect tool cords periodically and if damaged, have repaired by authorized service facility. Inspect extension cords periodically and replace if damaged. Keep handles dry, clean, and free from oil and grease.
- **DISCONNECT OR LOCK OFF TOOLS** when not in use, before servicing, and when changing accessories, such as blades, bits, cutters.
- **REMOVE ADJUSTING KEYS AND WRENCHES.** Form habit of checking to see that keys and adjusting wrenches are removed from tool before turning it on.

1

- **AVOID UNINTENTIONAL STARTING.** Don't carry tool with finger on switch. Be sure switch is off when plugging in.
- **EXTENSION CORDS.** Make sure your extension cord is in good condition. When using an extension cord, be sure to use one heavy enough to carry the current your product will draw. An undersized cord will cause a drop in line voltage resulting in loss of power and overheating. The following table shows the correct size to use depending on cord length and nameplate ampere rating. If in doubt, use the next heavier gage. The smaller the gage number, the heavier the cord.

Minimum Gage for Cord Sets

Volts	Total Length of Cord in Feet				
	0-25	26-50	51-100	101-150	
120V	0-50	51-100	101-200	201-300	
240V					
Ampere Rating		AWG			
More Than	Not more Than				
0	- 6	18	16	16	14
6	- 10	18	16	14	12
10	- 12	16	16	14	12
12	- 16	14	12	Not Recommended	

- **OUTDOOR USE EXTENSION CORDS.** When tool is used outdoors, use only extension cords intended for use outdoors and so marked.
- **STAY ALERT.** Watch what you are doing. Use common sense. Do not operate tool when you are tired.
- **CHECK DAMAGED PARTS.** Before further use of the tool, a guard or other part that is damaged should be carefully checked to determine that it will operate properly and perform its intended function. Check for alignment of moving parts, binding of moving parts, breakage of parts, mounting, and any other conditions that may affect its operation. A guard or other part that is damaged should be properly repaired or replaced by an authorized service center unless otherwise indicated elsewhere in this instruction manual. Have defective switches replaced by authorized service center. Do not use tool if switch does not turn it on and off.

- **CAUTION:** When drilling or driving into walls, floors or wherever live electrical wires may be encountered, DO NOT TOUCH ANY METAL PARTS OF THE TOOL! Hold the tool only by insulated grasping surfaces to prevent electric shock if you drill or drive into a live wire.

SAVE THESE INSTRUCTIONS

TOOL OPERATION

Spade Handle

The spade handle can be attached either horizontally or vertically. Place the handle into the locating boss on the back of the drill and assemble with holding knob (Figure 1).

Side Handle

The side handle screws into the top or either side of the drill for added control (Figure 1).

CAUTION: Always use and hold firmly the side handle or spade handle. This is a high-torque drill- always hold it with both hands when operating.

Switch

(Figure 2) Pressing the top part of the rocker switch runs the tool in reverse. Pressing the bottom part of the switch runs the tool in a forward direction. Always let the motor stop completely before changing direction.

To lock trigger in forward position, depress lower part of trigger and push up lock button (Figure 2). Then, while holding lock button in position, gently release trigger. To release locking mechanism, depress trigger fully, then release it.

NOTE: The locking mechanism will not function if the upper part of trigger is depressed (reverse operation). Do not lock the switch on when drilling by hand so that you can instantly release the trigger switch if the bit binds in the hole. The locking feature is for use when the drill is mounted in a drill stand or otherwise firmly held- NOT BY HAND.

Be sure to release the switch locking button before disconnecting the plug from the power supply. Failure to do so will cause the tool to start immediately the next time it is plugged in. Damage or injury could result.

Chuck

To insert bit, open chuck jaws by turning collar with fingers and insert shank of bit about 3/4" into chuck. Tighten chuck collar by hand. Place chuck key in each of the three holes and tighten in clockwise direction. It's important to tighten chuck with all three holes.

To release bit, turn chuck key counterclockwise in just one hole, then loosen the chuck by hand.

Chuck Key Holder

May be installed already.

1. Push double hole end of holder through slot in other end of holder as shown in Figure 3.
2. Slip loop over electric plug and draw loop tight around cord.
3. Push ends of chuck key handle through two holes in end of holder.

Chuck Removal

1. TURN OFF TOOL AND DISCONNECT FROM POWER SUPPLY.
2. Place chuck key in chuck as shown in Figure 4.
3. Using a wooden mallet or similar object, strike key sharply in a clockwise direction. This will loosen screw inside chuck (Figure 4).

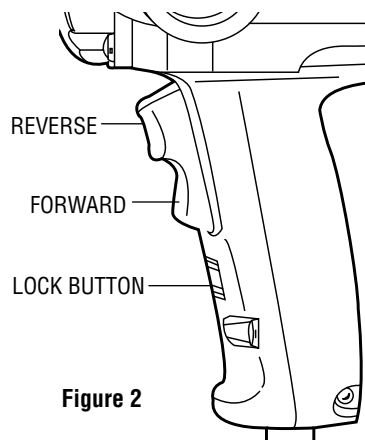
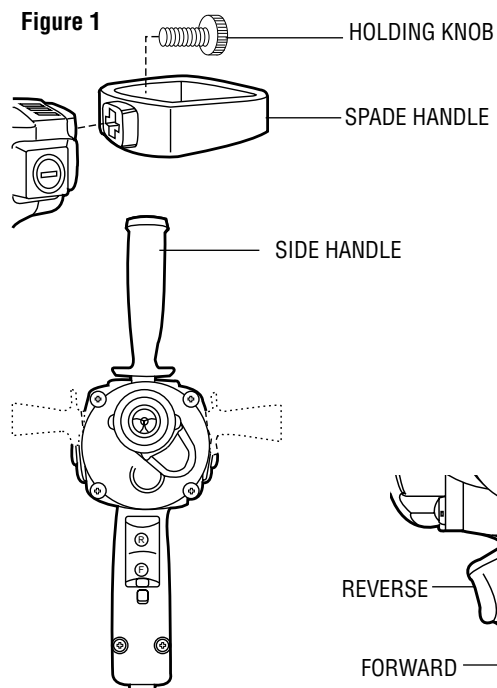

3

4. Open chuck jaws fully. Insert screwdriver (or 3/16" hex wrench if required) into front of chuck between jaws to engage screw head.
5. Remove screw by turning clockwise (left-hand thread).
6. Place key in chuck as shown in Figure 5.
7. Using a wooden mallet or similar object, strike key sharply in a counterclockwise direction. This will loosen chuck so that it can be unscrewed by hand (Figure 5).

Drilling

1. Always turn off tool and disconnect from power supply when attaching or changing bits or accessories.
2. Use sharp drill bits only. For WOOD, use twist drill bits, spade bits, power auger bits, or hole saws. For METAL, use high speed steel twist drill bits or hole saws. For MASONRY, such as brick, cement, cinder block, etc., use carbide-tipped bits

Figure 3

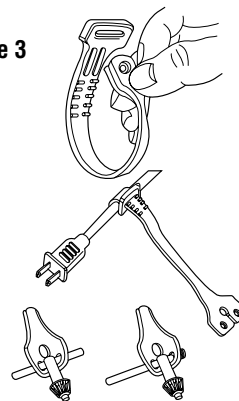

3. Be sure the material to be drilled is anchored or clamped firmly. If drilling thin material, use a "back-up" block to prevent damage to the material.
4. Always apply pressure in a straight line with the bit. Use enough pressure to keep the drill bit biting, but do not push hard enough to stall the motor or deflect the bit.
5. Hold tool firmly to control the twisting action of the drill.
6. IF DRILL STALLS, it is usually because it is being overloaded. RELEASE TRIGGER IMMEDIATELY, remove drill bit from work, and determine cause of stalling. DO NOT CLICK TRIGGER OFF AND ON IN AN ATTEMPT TO START A STALLED DRILL – THIS CAN DAMAGE THE DRILL.
7. To minimize stalling on breaking through the material, reduce pressure on drill and ease the bit through the last fractional part of the hole.
8. Keep the motor running when pulling the bit back out of a drilled hole. This will help prevent jamming.

Drilling in Wood

Holes in wood can be made with the same twist drills used for metal. These bits may overheat unless pulled out frequently to clear chips from the flutes. For larger holes, use spade bits, power auger bits, or hole saws. Work that is likely to splinter should be backed up with a block of wood.

Figure 4

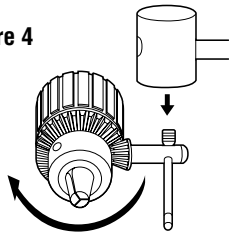
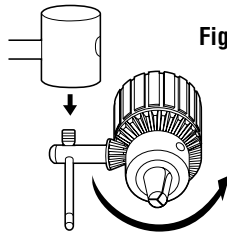

Figure 5



4

Drilling in Metals

Use a cutting lubricant when drilling metals. The exceptions are cast iron and brass which should be drilled dry. The cutting lubricants that work best are sulphurized cutting oil or lard oil; bacon grease will also serve the purpose.

Drilling in Masonry

Use carbide tipped masonry bits at low speeds. Keep even force on the drill but not so much that you crack the brittle materials. A smooth, even flow of dust indicates the proper drilling rate.

Lubrication

All ball and sleeve bearings used are factory lubricated to last the life of the bearings. All needle bearings used receive their lubrication from the grease in the gear case. Clean and relubricate gear case yearly or whenever servicing requires the gear case to be removed. Use type and quantity of grease shown on Parts Bulletin packed with your tool. Gear case is removed by removing the three screws from the front of the tool. If the chuck is too large to permit removal of the two top screws, see instructions for chuck removal.

Motor Brushes

TURN OFF TOOL AND DISCONNECT FROM POWER SUPPLY.

To inspect brushes, unscrew the plastic brush inspection caps (located in the sides of the motor housing) and the spring and brush assemblies may be withdrawn from the tool. Keep brushes clean and sliding freely in their guides. Carbon brushes have varying symbols stamped into them, and if the brush is worn down to a point where the symbol is not visible, they must be replaced. New brush assemblies are available at B&D authorized service centers.

NOTE: This tool uses the CHECKPOINT™ brush system and is designed to automatically turn itself off when the brushes are worn out.

Important

To assure product SAFETY and RELIABILITY, repairs, maintenance and adjustment (including brush inspection and replacement) should be performed by authorized service centers or other qualified service organizations, always using identical replacement parts.

Accessories

Recommended accessories for use with your tool are available at extra cost from your distributor or local service center.

CAUTION: The use of any non-recommended accessory may be hazardous.

If you need any assistance in locating any accessory call 1-800-9-BD TOOL: (1-800-923-8665) or contact Black & Decker (U.S.) Inc., Consumer Services Department, 626 Hanover Pike, P.O. Box 618, Hampstead, MD 21074.

MAXIMUM RECOMMENDED CAPACITIES

Steel twist bit	1/2"
Auger	1-1/2"
Self-feed	3"
Spade	1-1/2"
Wood holesaw	5"
Steel holesaw	4"

ACCESSORY MUST BE RATED FOR USE AT SPEED EQUAL TO OR HIGHER THAN NAMEPLATE RPM OF TOOL WITH WHICH IT IS BEING USED.

Every B&D tool is of the highest quality.

If you wish to contact us regarding this product, please call toll free between 8:00am and 8:00pm ET, seven days a week:

1-800-9-BD TOOL

(1-800-923-8665)

One Year Free Maintenance

All B&D tools for Industry and Construction are covered under a one year free maintenance program where B&D will inspect your tool for safety and provide necessary maintenance or repairs, including normal wear and tear parts, for one year, FREE OF CHARGE.

Full Warranty

All B&D tools for Industry and Construction are warranted to be free of any defects in materials or workmanship. Upon thorough examination of tool, B&D will repair or replace, at our option, any product that is determined to be defective.

Conditions

The service/safety check and the warranty do not apply to: repairs made or attempted by anyone other than an authorized B&D service location; misuse, abuse, neglect, improper application of the tool; missing parts; or normal wear and tear (after first year of ownership). Please return the complete unit, transportation prepaid, to any B&D factory owned or B&D authorized service center location (list provided with tool or see yellow pages under "Tools Electric").