

Black & Decker (U.S.) Inc. • 701 East Joppa Road, Towson, Maryland 21286
Printed in U.S.A. (JAN96-CD-1) Form No. 154559 Copyright © 1996

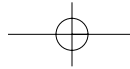



Instruction Manual

2750-220

4-1/2" Small Angle Grinder

Getting the most out of your tool.

Please take time to read this manual and pay particular attention to the safety rules we've provided for your protection. Don't forget to send in your owner's registration card. If you have any questions about your tool please call:

1-800-9-BD TOOL
(1-800-923-8665)

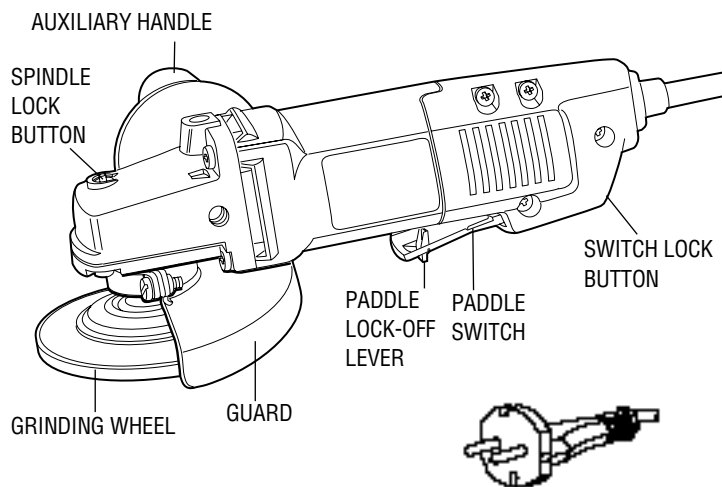

2750-220 4-1/2" Angle Grinder with 220 volt plug

FOR YOUR SAFETY - ALL TOOLS

WARNING: When using electric tools, basic safety precautions should be followed to reduce risk of fire, electric shock, and personal injury, including the following:

READ ALL INSTRUCTIONS

Double Insulation

Double insulated tools are constructed throughout with two separate layers of electrical insulation or one double thickness of insulation between the tool's electrical system and the tool's electrical system. Tools built with this insulation system are not intended to be grounded. As a result, your tool is equipped with a two-prong plug which permits you to use extension cords without concern for maintaining a ground connection.

NOTE: Double insulation does not take the place of normal safety precautions when operating this tool. The insulation system is for protection against injury resulting from a possible electrical insulation failure within the tool.

CAUTION: WHEN SERVICING USE ONLY IDENTICAL REPLACEMENT PARTS. Repair or replace damaged cords.

Safety Instructions For All Tools

- **KEEP WORK AREA CLEAN.** Cluttered areas and benches invite injuries.
- **CONSIDER WORK AREA ENVIRONMENT.** Don't expose power tools to rain. Don't use power tools in damp or wet locations. Keep work area well lit. Do not use tool in presence of flammable liquids or gases.
- **GUARD AGAINST ELECTRIC SHOCK.** Prevent body contact with grounded surfaces. For example; pipes, radiators, ranges, and refrigerator enclosures.
- **KEEP CHILDREN AWAY.** Do not let visitors contact tool or extension cord. All visitors should be kept away from work area.
- **STORE IDLE TOOLS.** When not in use, tools should be stored in dry, and high or locked-up place — out of reach of children.
- **DON'T FORCE TOOL.** It will do the job better and safer at the rate for which it was intended.
- **USE RIGHT TOOL.** Don't force small tool or attachment to do the job of a heavy-duty tool. Don't use tool for purpose not intended.
- **DRESS PROPERLY.** Do not wear loose clothing or jewelry. They can be caught in moving parts. Rubber gloves and non-skid footwear are recommended when working outdoors. Wear protective hair covering to contain long hair.
- **USE SAFETY GLASSES.** Also use face or dust mask if operation is dusty.
- **DON'T ABUSE CORD.** Never carry tool by cord or yank it to disconnect from receptacle. Keep cord from heat, oil, and sharp edges.
- **SECURE WORK.** Use clamps or a vise to hold work. It's safer than using your hand and it frees both hands to operate tool.
- **DON'T OVERREACH.** Keep proper footing and balance at all times.
- **MAINTAIN TOOLS WITH CARE.** Keep tools sharp and clean for better and safer performance. Follow instructions for lubricating and changing accessories. Inspect tool cords periodically and if damaged, have repaired by authorized service facility. Inspect extension cords periodically and replace if damaged. Keep handles dry, clean, and free from oil and grease.

- **DISCONNECT OR LOCK OFF TOOLS** when not in use, before servicing when changing accessories, such as blades, bits, cutters.
- **REMOVE ADJUSTING KEYS AND WRENCHES.** Form habit of check see that keys and adjusting wrenches are removed from tool before t it on.
- **AVOID UNINTENTIONAL STARTING.** Don't carry tool with finger on s Be sure switch is off when plugging in.
- **EXTENSION CORDS.** Make sure your extension cord is in good con When using an extension cord, be sure to use one heavy enough to the current your product will draw. An undersized cord will cause a d line voltage resulting in loss of power and overheating. The following shows the correct size to use depending on cord length and nam ampere rating. If in doubt, use the next heavier gage. The smaller the number, the heavier the cord.
- **OUTDOOR USE EXTENSION CORDS.** When tool is used outdoors, us extension cords intended for use outdoors and so marked.

Volts	Minimum Gage for Cord Sets				
	Total Length of Cord in Feet				
120V	0-25	26-50	51-100	101-150	
240V	0-50	51-100	101-200	201-300	
Ampere Rating					
More Than	Not more Than	American Wire Gage			
0	- 6	18	16	16	14
6	- 10	18	16	14	12
10	- 12	16	16	14	12
12	- 16	14	12	Not Recommended	

- **STAY ALERT.** Watch what you are doing. Use common sense. Do not operate tool when you are tired.
- **CHECK DAMAGED PARTS.** Before further use of the tool, a guard or other part that is damaged should be carefully checked to determine that it will operate properly and perform its intended function. Check for alignment of moving parts, binding of moving parts, breakage of parts, mounting, and any other conditions that may affect its operation. A guard or other part that is damaged should be properly repaired or replaced by an authorized service center unless otherwise indicated elsewhere in this instruction manual. Have defective switches replaced by authorized service center. Do not use tool if switch does not turn it on and off.

ADDITIONAL SAFETY INSTRUCTIONS

- **ALWAYS WEAR EYE PROTECTION.**
- **KEEP GUARDS IN PLACE.**
- Use only grinding wheels having a maximum operating speed at least as "No Load RPM" marked on the tool's nameplate.
- Before using, inspect recommended accessory for cracks or flaws. If a crack or flaw is evident, discard the accessory. The accessory should be inspected whenever you think the tool may have been dropped.
- When starting the tool (with a new or replacement wheel installed) hold the tool in a well protected area and let it run for one minute. If the wheel has an undetected crack or flaw, it should burst in less than one minute. Never operate the tool with a person in line with the wheel. This includes the operator.
- In operation, avoid bouncing the wheel or giving it rough treatment. If a vibration occurs, stop the tool and inspect the wheel.
- Always use guards with depressed center wheels or flaring cup grinding wheels.
- Clean your tool out periodically.
- **CAUTION:** Some wood contains preservatives such as copper chromate arsenate (CCA) which can be toxic. When sanding these materials extra care should be taken to avoid inhalation and minimize skin contact.

**SAVE THESE INSTRUCTIONS
FOR FUTURE USE**

Auxiliary Handle

An auxiliary handle is furnished with your grinder and can be installed on either side of the front housing. **THIS HANDLE SHOULD BE USED AT ALL TIMES** to maintain complete control of the tool.

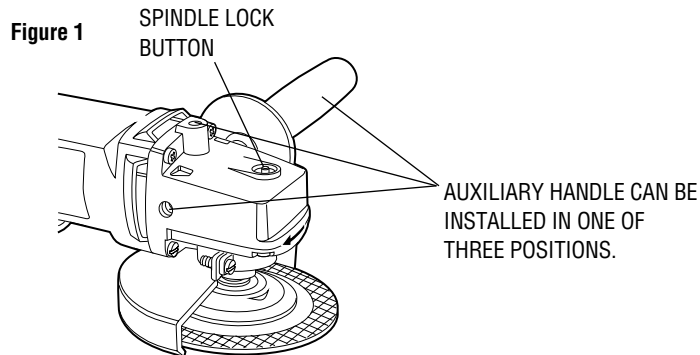

TOOL OPERATION

Paddle Switch

To start the grinder, slide the lock off lever to the rear of the tool while you are depressing it at the same time. To turn the tool off, release the paddle. The switch can be locked on by engaging the lock button located near the rear of the tool while holding the paddle depressed. Always be sure that the tool is not locked on before plugging it in. To turn the tool off when it is locked on, squeeze and release the paddle once.

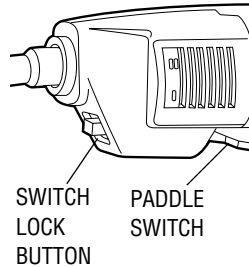

Spindle Lock Button

Turn off and unplug grinder. In order to prevent the spindle of the tool from rotating while installing or removing accessories, a spindle lock button has been provided in the gear head of the machine, as shown in Figure 1. Depress the spindle lock button and rotate the spindle until the lock pin engages the spindle. **NEVER DEPRESS THE LOCK BUTTON WITH THE TOOL RUNNING OR COASTING.**

Sanding With Abrasive Discs (Figure 3)

To install sanding discs:

1. TURN OFF TOOL AND DISCONNECT FROM POWER SUPPLY.
2. Push the hub of the disc nut through the center of the sanding disc as far as it will go, and also through the backing disc.
3. Put the assembled discs on the tool spindle and engage the disc into the disc nut hub.

4. Thread the assembly clockwise, completely down on the spindle.
5. Engage the lock button to lock the spindle in place.

When using a sanding disc, hold the tool at an angle of 10°-15° to the work as shown in Figure 4. If only the outer edge of the sanding disc is used, a rough cut surface will result. If the sanding disc is pressed flat against the work, the surface will be irregular and bumpy, and the tool will be difficult to control.

Figure 3

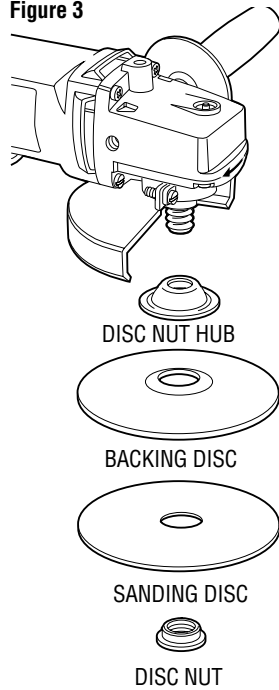
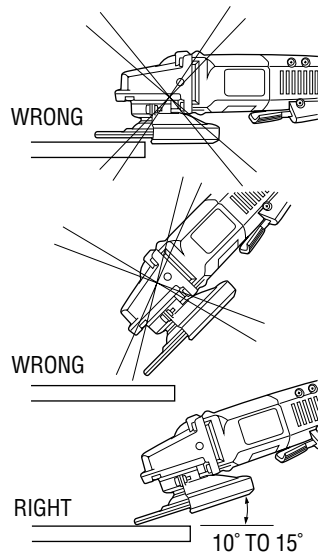

Figure 4



To remove disc:

1. Engage spindle lock button to lock the spindle in place.
2. Using a cloth or glove to protect your hand, turn disc assembly counterclockwise to remove it from the tool spindle.

Depressed-Center Wheels

Depressed center wheels may be used for moderate metal removal on flat or contoured surfaces (see Figure 5).

CAUTION: Never use depressed center wheels without the proper guard.

To install depressed center wheels:

1. TURN OFF TOOL AND DISCONNECT FROM POWER SUPPLY.
2. Be sure the guard assembly is securely attached to the spindle housing. Position guard so that the open part of the guard is facing away from the operator.
3. Put the backing flange onto the tool spindle.
4. Check rated speed on depressed center wheel. Never use wheel with rated speed lower than the speed in the "WARNING" statement on the nameplate of the tool.

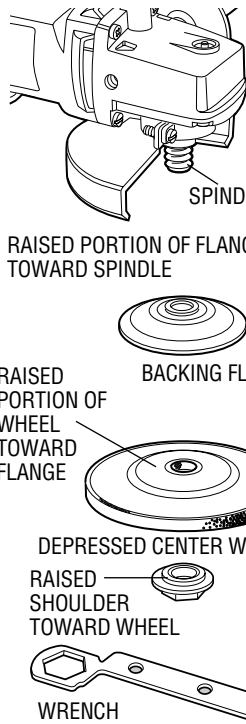

5. Place the depressed center wheel on the tool spindle.
6. Thread the clamp washer on tool spindle, hold the tool spindle by engaging the lock button, and tighten clamp washer with wrench.

When using a depressed center wheel, hold the tool so that an angle of approximately 30° exists between the wheel and the work.

Wire Brushing

Common applications for wire cup brushes include cleaning welds, angles, corners and removal of paint.

1. Disconnect tool from power source. Rest grinder on its back with spindle facing up.
2. Ensure that the rated speed of the wire brush is equal to or higher than the rated speed of the grinder found on the nameplate.
3. Thread wire cup brush onto spindle and tighten.
4. Always wear eye protection and appropriate protective clothing.

Precautions To Take When Sanding Paint

1. Sanding of lead based paint is NOT RECOMMENDED due to the difficulty of controlling the contaminated dust. The greatest danger of lead poisoning is to children and pregnant women.
2. Since it is difficult to identify whether or not a paint contains lead without a chemical analysis, we recommend the following precautions when sanding any paint:

PERSONAL SAFETY

- a. No children or pregnant women should enter the work area where the paint sanding is being done until all clean up is completed.
- b. A dust mask or respirator should be worn by all persons entering the work area. The filter should be replaced daily or whenever the wearer has difficulty breathing.

NOTE: Only those dust masks suitable for working with lead paint and fumes should be used. Ordinary painting masks do not offer protection. See your local hardware dealer for the proper N.I.C. approved mask.

- c. NO EATING, DRINKING or SMOKING should be done in the work area to prevent ingesting contaminated paint particles. Workers should clean up BEFORE eating, drinking or smoking. Articles of clothing, drink, or smoking should not be left in the work area where dust will settle on them.

ENVIRONMENTAL SAFETY

- a. Paint should be removed in such a manner as to minimize the amount of dust generated.
- b. Areas where paint removal is occurring should be sealed with plastic sheeting of 4 mils thickness.
- c. Sanding should be done in a manner to reduce tracking of paint chips outside the work area.

CLEANING AND DISPOSAL

- a. All surfaces in the work area should be vacuumed and thoroughly cleaned daily for the duration of the sanding project. Vacuum filters should be changed frequently.
- b. Plastic drop cloths should be gathered up and disposed of along with any dust chips or other removal debris. They should be placed in sealed refuse receptacles and disposed of through regular trash pick-up procedures.

During clean up, children and pregnant women should be kept away from the immediate work area.

- c. All toys, washable furniture and utensils used by children should be washed thoroughly before being used again.

MAINTENANCE

Cleaning

Blowing dust and grit out of the motor housing using compressed air is a necessary regular maintenance procedure. Dust and grit containing metal particles often accumulate on interior surfaces and could create an electrical shock hazard if not frequently cleaned out. **ALWAYS WEAR SAFETY GLASSES.**

CAUTION: Never use solvents or other harsh chemicals for cleaning the non-metallic parts of the tool. Use clean, dry rag only.

Lubrication

B&D tools are properly lubricated at the factory and are ready for use. Tools should be relubricated regularly every sixty days to six months, depending on usage. (Tools used constantly on production or heavy-duty jobs and tools exposed to heat may require more frequent lubrication.) This lubrication should only be attempted by trained power tool repairpersons, such as those at B&D service centers or in other qualified service organizations.

Motor Brushes

Your tool is equipped with the B&D CHECKPOINT™ system. When the brushes become worn out, the tool will automatically stop and prevent damage to the motor. Brush replacement should be performed by B&D authorized service centers.

IMPORTANT!

To assure product safety and reliability, particularly for double insulated tools, repairs, maintenance and adjustment (excluding maintenance described in this manual) should be performed by B&D service centers or authorized service centers, using identical B&D replacement parts.

ACCESSORIES

NOTE: Use accessories recommended per chart below:

Accessory Type	Notes	Usage
DEPRESSED CENTER WHEEL	Use guard supplied with Tool	Use for moderate metal and masonry removal on flat or contour surfaces
SANDING DISCS		Use for smoothing welds and sharp edges, and automotive body preparation
WIRE CUP BRUSHES	MAX- 4" KNOTTED WHEEL MAX- 2-3/4" CUP WHEEL	Use for rust removal and surface preparation before painting

Depressed center grinding wheels must fit within the confines of the tool and must be rated higher than the recommended speed as marked on the nameplate.

CAUTION: Strands of wire cup brushes may break and fly off while in use. Users and others in the area should wear adequate eye, face and head protection. Use only wire cup brushes that are rated at or greater than the RPM shown on the tool's nameplate.

WARNING: To reduce the risk of injury, always use proper guards during grinding and wear eye protection.

CAUTION: The use of any non-recommended accessory may be hazardous. Recommended accessories for use with your tool are available at extra cost from your distributor or local service center. A complete listing of service centers is included with your tool.

If you need any assistance in locating any accessory call: 1-800-9-BD TOOL (1-800-923-8665) or contact Black & Decker (U.S.) Inc., Consumer Services Department, 626 Hanover Pike, P.O. Box 618, Hampstead, MD 21074.

Every B&D tool is of the highest quality.

If you wish to contact us regarding this product, please call toll free between 8:00am and 8:00pm ET, seven days a week:

1-800-9-BD TOOL
(1-800-923-8665)

One Year Free Maintenance

All B&D tools for Industry and Construction are covered under a one year free maintenance program where B&D will inspect your tool for safety and provide necessary maintenance or repairs, including normal wear and tear on parts, for one year, FREE OF CHARGE.

Full Warranty

All B&D tools for Industry and Construction are warranted to be free of defects in materials or workmanship. Upon thorough examination of the tool, B&D will repair or replace, at our option, any product that is determined to be defective.

Conditions

The service/safety check and the warranty do not apply to: repairs made or attempted by anyone other than an authorized B&D service location; misuse, abuse, neglect, improper application of the tool; missing parts; or normal wear and tear (after first year of ownership). Please return the complete tool with transportation prepaid, to any B&D factory owned or B&D authorized service center location (list provided with tool or see yellow pages under "Tools Electric").