

---

**Black & Decker (U.S.) Inc. • 701 East Joppa Road, Towson, Maryland 21286**  
Printed in Italy (JUN96-1) Form No. 154708 Copyright © 1996

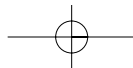



# **Instruction Manual**

## **3339-220 3.0 H.P. Plunge Cut Router**

## Getting the most out of your tool.

Please take time to read this manual and pay particular attention to the safety rules we've provided for your protection. If you have any questions about your tool please call:

**1-800-9-BD TOOL**  
**(1-800-923-8665)**

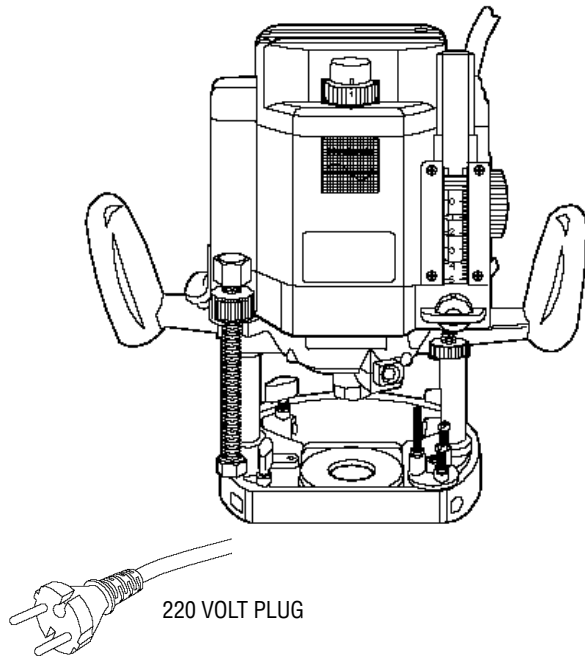

## **IMPORTANT SAFETY INSTRUCTIONS**

### **Important Safety Instructions**

**WARNING:** When using electric tools, basic safety precautions should always be followed to reduce risk of fire, electric shock, and personal injury, including the following:

#### **READ ALL INSTRUCTIONS**

### **Double Insulation**

Double insulated tools are constructed throughout with two separate layers of electrical insulation or one double thickness of insulation between you and the tool's electrical system. Tools built with this insulation system are not intended to be grounded. As a result, your tool is equipped with a two prong plug which permits you to use extension cords without concern for maintaining a ground connection.

**NOTE:** Double insulation does not take the place of normal safety precautions when operating this tool. The insulation system is for added protection against injury resulting from a possible electrical insulation failure within the tool.

**CAUTION:** WHEN SERVICING USE ONLY IDENTICAL REPLACEMENT PARTS. Repair or replace damaged cords.

## Safety Instructions For All Tools

- **KEEP WORK AREA CLEAN.** Cluttered areas and benches invite injuries.
- **CONSIDER WORK AREA ENVIRONMENT.** Don't expose power tools to rain. Don't use power tools in damp or wet locations. Keep work area well lit. Do not use tool in presence of flammable liquids or gases.
- **GUARD AGAINST ELECTRIC SHOCK.** Prevent body contact with grounded surfaces. For example; pipes, radiators, ranges, and refrigerator enclosures.
- **KEEP CHILDREN AWAY.** Do not let visitors contact tool or extension cord. All visitors should be kept away from work area.
- **STORE IDLE TOOLS.** When not in use, tools should be stored in dry, and high or locked-up place — out of reach of children.
- **DON'T FORCE TOOL.** It will do the job better and safer at the rate for which it was intended.
- **USE RIGHT TOOL.** Don't force small tool or attachment to do the job of a heavy-duty tool. Don't use tool for purpose not intended.
- **DRESS PROPERLY.** Do not wear loose clothing or jewelry. They can be caught in moving parts. Rubber gloves and non-skid footwear are recommended when working outdoors. Wear protective hair covering to contain long hair.
- **USE SAFETY GLASSES.** Also use face or dust mask if operation is dusty.
- **DON'T ABUSE CORD.** Never carry tool by cord or yank it to disconnect from receptacle. Keep cord from heat, oil, and sharp edges.
- **SECURE WORK.** Use clamps or a vise to hold work. It's safer than using your hand and it frees both hands to operate tool.
- **DON'T OVERREACH.** Keep proper footing and balance at all times.
- **MAINTAIN TOOLS WITH CARE.** Keep tools sharp and clean for better and safer performance. Follow instructions for lubricating and changing accessories. Inspect tool cords periodically and if damaged, have repaired by authorized service facility. Inspect extension cords periodically and replace if damaged. Keep handles dry, clean, and free from oil and grease.
- **DISCONNECT OR LOCK OFF TOOLS** when not in use, before servicing, and when changing accessories, such as blades, bits, cutters.
- **REMOVE ADJUSTING KEYS AND WRENCHES.** Form habit of checking to see that keys and adjusting wrenches are removed from tool before turning it on.

- **AVOID UNINTENTIONAL STARTING.** Don't carry tool with finger on switch. Be sure switch is off when plugging in.
- **EXTENSION CORDS.** Make sure your extension cord is in good condition. When using an extension cord, be sure to use one heavy enough to carry the current your product will draw. An undersized cord will cause a drop in line voltage resulting in loss of power and overheating. The following table shows the correct size to use depending on cord length and nameplate ampere rating. If in doubt, use the next heavier gage. The smaller the gage number, the heavier the cord.

Volts	Minimum Gage for Cord Sets				
	Total Length of Cord in Feet				
120V	0-25	26-50	51-100	101-150	
240V	0-50	51-100	101-200	201-300	
Ampere Rating		AWG			
More Than	Not more Than				
0	- 6	18	16	16	14
6	- 10	18	16	14	12
10	- 12	16	16	14	12
12	- 16	14	12	Not Recommended	

- **OUTDOOR USE EXTENSION CORDS.** When tool is used outdoors, use only extension cords intended for use outdoors and so marked.
- **STAY ALERT.** Watch what you are doing. Use common sense. Do not operate tool when you are tired.
- **CHECK DAMAGED PARTS.** Before further use of the tool, a guard or other part that is damaged should be carefully checked to determine that it will operate properly and perform its intended function. Check for alignment of moving parts, binding of moving parts, breakage of parts, mounting, and any other conditions that may affect its operation. A guard or other part that is damaged should be properly repaired or replaced by an authorized service center unless otherwise indicated elsewhere in this instruction manual. Have defective switches replaced by authorized service center. Do not use tool if switch does not turn it on and off.

**SAVE THESE INSTRUCTIONS**

## Motor

Your B&D tool is powered by a B&D built motor. Be sure your power supply agrees with the nameplate marking. Voltage decrease of more than 10% will cause loss of power and overheating. All B&D tools are factory tested; if this tool does not operate, check the power supply.

## SPECIFICATIONS

### Preparation For Use

The motor in this router is high-powered. Despite this, it is advisable to cut deep grooves or remove large amounts of material in two or more passes.

### Technical Data

Voltage	220/240 AC only
Speed	8,000- 22,000 r.p.m.
Insulation	double insulated
Column	spring loaded twin column
Plunging stroke	70mm (2-3/4")
Routing depth	0-70 mm adjustable
Cutter mounting	precision collet, size 1/2"(12.9 mm)
Cutter cap routing	max. 2-1/2" (63.5 mm) (shallow)
Rotary depth stop	3 stage depth position

## OPERATING INSTRUCTIONS

### TURN OFF AND UNPLUG ROUTER

**NOTE:** Before installing a router bit in your unit, position the tool so that the collet is easily accessible. To do this, rotate the height stop thumb wheel, shown in Figure 1, counterclockwise until it is about 1/2" from the top of the threaded height stop rod. Raise the plunge release lever, shown in Figure 2, and let the router rise to its full height. Depress the plunge release lever to lock the tool in place.

### Bit Installation and Removal

#### TURN OFF AND UNPLUG ROUTER

**IMPORTANT NOTE:** Always snap the collet firmly into the collet nut, (past the retainer spring) before installing a bit.

Use the supplied wrench and the spindle lock as necessary to loosen (counterclockwise) the collet nut, as shown in Figure 3.

Insert the round shank of the desired router bit into the loosened collet as far as it will go and then pull it out about 1/16". Hold the spindle shaft by depressing the spindle lock button, shown in figure 3, while firmly tightening the collet nut with the wrench provided.

Your router has a unique locking system for retaining the bit. When removing a bit, the collet nut must be loosened with the wrench. The collet nut will turn approximately 3/4 of a turn and then become tight again. At this point the bit can't be removed. Using the same procedure, loosen the nut a second time. This lifts the collet and makes it very easy to remove the bit.

Figure 1

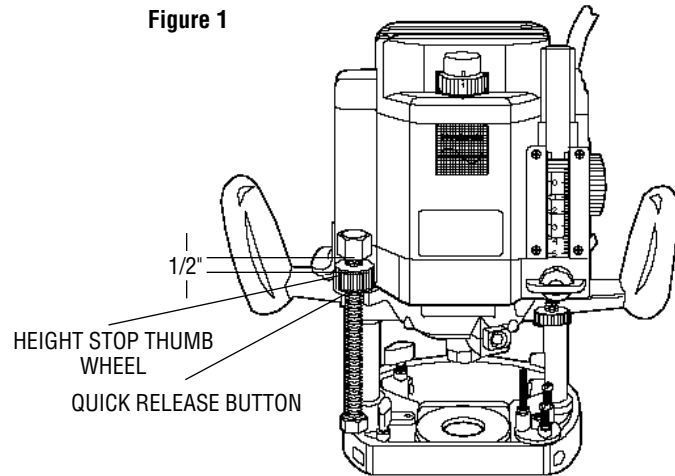
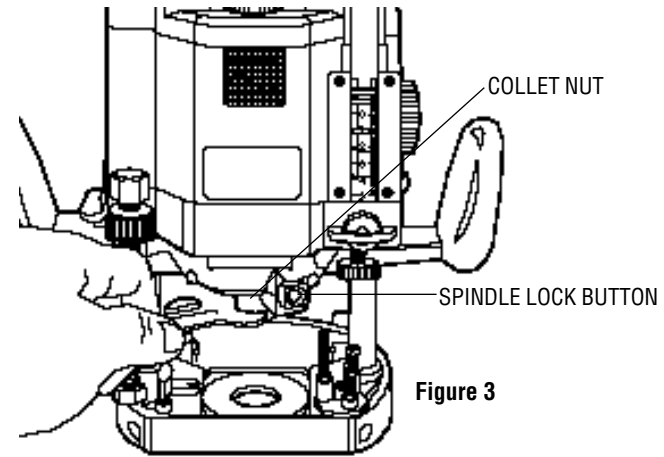
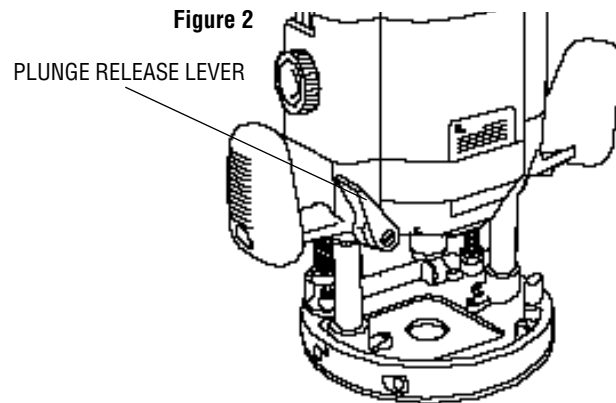

Figure 2



### Collets

NEVER TIGHTEN THE COLLET ON THIS TOOL WITHOUT FIRST INSTALLING A ROUTER BIT IN IT. TIGHTENING AN EMPTY COLLET CAN DAMAGE THE COLLET.

To change collets, unscrew the collet assembly, as described above, sharply pull the old collet out of the collet nut and insert the new collet. Push firmly so that it snaps past the retainer spring in the collet nut.

### Controls

IMPORTANT NOTE: Before operating any of the controls, read this whole section.

## Plunge Release Lever

The plunge release lever allows the router bit to be plunged directly into the workpiece. Simply raise the plunge release lever when you want to lower the router into the work, as shown in Figure 2. You can lower the unit until it reaches your preset stop. To lock the tool in place anywhere along its vertical travel, depress the lever.

## Height Stop Rod and Height Stop Thumb Wheel

As its name implies, the height stop rod and thumb wheel limit how high the unit can travel up the rails. The system is adjustable from full down where the unit cannot rise regardless of the position of the plunge release lever to full up where the bottom of the collet is 2-7/8" above the workpiece (See Figure 4).

For convenience, the thumb wheel is equipped with a quick release button that allows you to disengage the threads for fast positioning by simply depressing the button in the side of the wheel.

NOTE: It is easier to move the height stop thumb wheel UP if the plunge release lever is locked and easier to move the thumb wheel DOWN if the unit is first moved down by releasing the plunge release lever and then tightening it.

## Multi-Position Turret Stop

The turret stop limits the downward distance that the tool can be plunged. It consists of three screws of different lengths that serve to define the depth of cut by limiting the travel of the depth stop bar (see Figure 5). Routing depth can be set by selecting the screw of the appropriate length on the turret. The turret is rotatable with detent stops to properly align the screws.

It is the interaction of the depth stop bar and the turret stop that determine the routing depth.

Figure 4

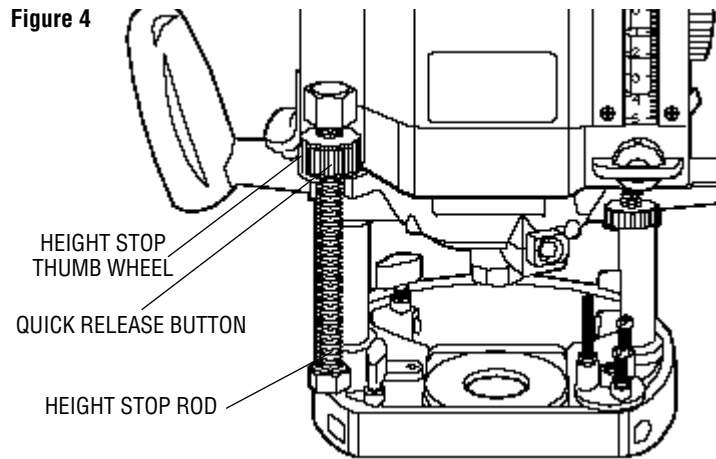
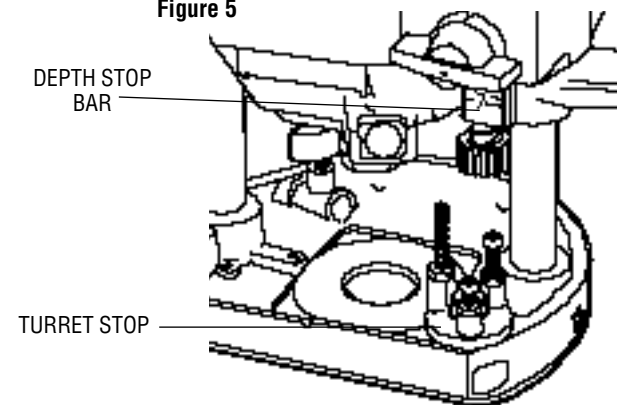
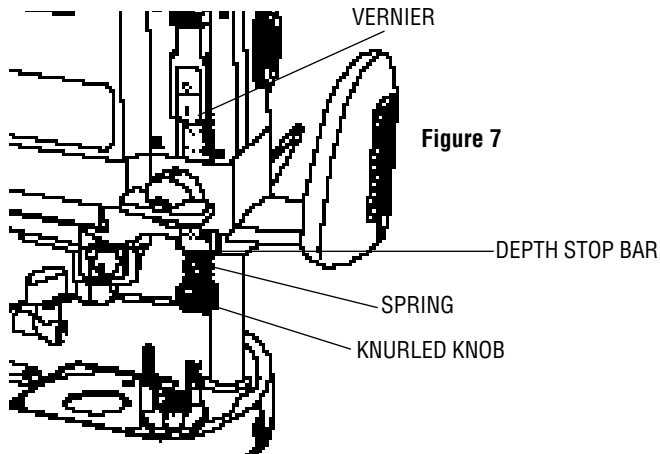
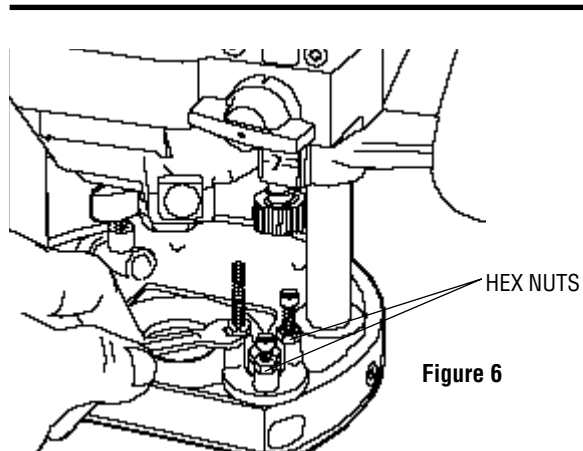

Figure 5







If none of the provided screws seems close to the desired height each can be adjusted by loosening the hex nut at the bottom and then turning the screw either in or out to make it the proper length. After adjusting this screw be sure to tighten the hex nut at the bottom. (See Figure 6).

See the section “Setting the Routing Depth” for instructions on how to use the turret stop in an actual operation.

### Depth Stop Bar and Vernier

The depth stop bar is what contacts the selected screw in the turret stop to limit the routing depth. At the bottom of the depth stop bar is a threaded shaft, a spring and a knurled knob, as shown in Figure 7.

A precision vernier scale is provided for extremely accurate adjustment of the routing depth.

See the section below “Setting the Routing Depth” for instructions on how to use the depth stop bar and vernier in an actual operation.

### Familiarization

Please take a little time now and, without plugging the tool in, practice with these adjustments and controls and become familiar with their operation. Only with a complete, “hands on” understanding of these systems will you be able to get the most out of this quality router.

### Setting the Routing Depth

#### TURN OFF AND UNPLUG THE ROUTER

To set the routing depth follow the steps below:

1. Install the desired router bit as described previously.
2. Position the height stop thumb wheel at the top of the height stop rod.

- (See Figure 4) You can either turn the thumb wheel or use the handy quick release button discussed above.
3. Adjust the depth stop bar to the top of its travel by rotating the depth stop control knob shown in Figure 9.
  4. Rotate the turret stop to position the shortest screw under the depth stop bar.
  5. Raise the plunge release lever and push the router down until the end of the bit just touches the workpiece.
  6. Lower the depth stop bar until the knurled knob on the bottom of it touches the selected screw in the turret stop.
  7. Raise or lower the plastic vernier to align the hairline in the vernier with the 0 mark on the graduated scale, as shown in Figure 8.
  8. Using the depth stop control knob, raise the depth stop bar and align the desired mark on the graduated scale with the hairline in the vernier, as shown in Figure 9. (Scale graduated in 1/16ths of an inch)
  9. Tighten the depth stop bar clamp.
  10. The router is now set to cut to the set depth when plunged into the workpiece.

### Fine Adjustment of Routing Depth

TURN OFF AND UNPLUG ROUTER.

If, after setting the desired depth of cut, a small adjustment is needed, it is not necessary to go through the entire procedure for setting the depth. Minor adjustment can be easily made by rotating the knurled knob on the bottom end of the depth stop bar, as shown in Figure 8.

Rotating the knob clockwise (looking down from the top of the router) will result in a more shallow cut. Rotating the knob counterclockwise will result in a deeper cut. One complete rotation of the knob represents about 1 mm in depth adjustment.

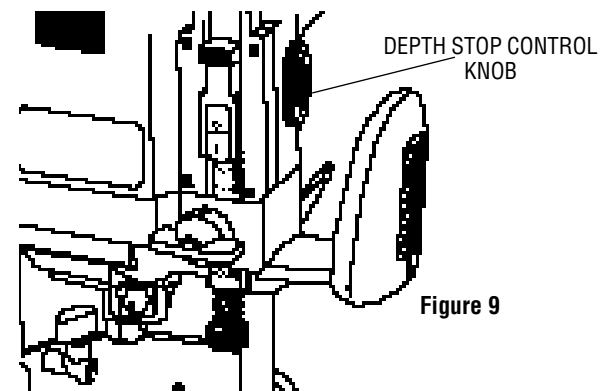
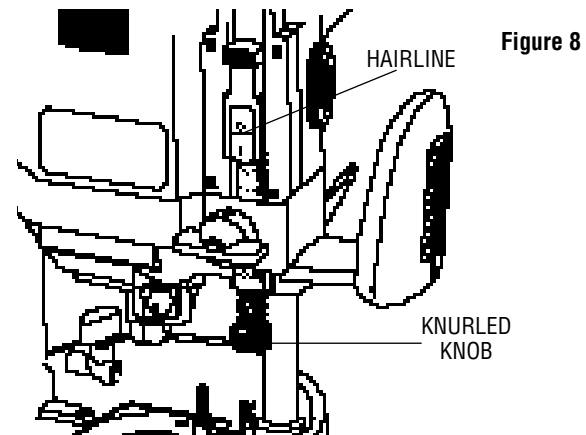

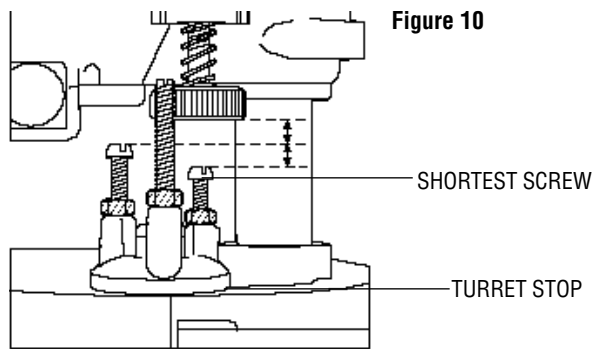

### Using the Turret Stop for Sequential Routing Depth Settings

TURN OFF AND UNPLUG ROUTER.

It is recommended that particularly deep grooves be cut with several passes rather than one deep pass. In order to do this and still maintain accuracy of depth when the job is finished, perform the following procedure.

1. Set the final desired routing depth as instructed above. For the purpose of this discussion, assume that the desired depth is 1/2".
2. With a depth of 1/2" set on the shortest screw in the turret stop, adjust the second shortest screw to a point about halfway between the bottom of the knurled knob and the top of the shortest screw, as shown in Figure 10.
3. Leave the vernier setting alone and turn the adjusted second shortest screw into position under the depth stop bar.
4. Make your first cut at this setting.

Figure 11

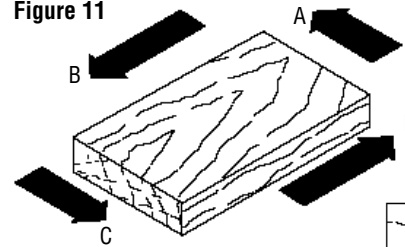
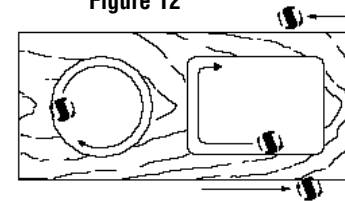

Figure 12



5. Rotate the turret stop so that the shortest screw is directly under the depth stop bar and make your final cut.

NOTE: The third screw in the turret stop is provided if your cut is even deeper and you want to make three cuts to achieve the final depth, or set final depth for multiple cuts at one time.

### Operation

After setting the cutting depth as described, locate the router such that the bit is directly over the place you will be cutting. With the router running, lower the unit smoothly down into the workpiece. (DO NOT JAM THE ROUTER DOWN). When the tool reaches the pre-set depth, depress the plunge lock lever. When you have finished routing, raise the lever and let the spring lift the router directly out of the workpiece.

All common routing tasks can be performed with ease with the plunge cut router: Grooving, rabbeting, recessing, veining, and profiling on all types of wood and plastic.

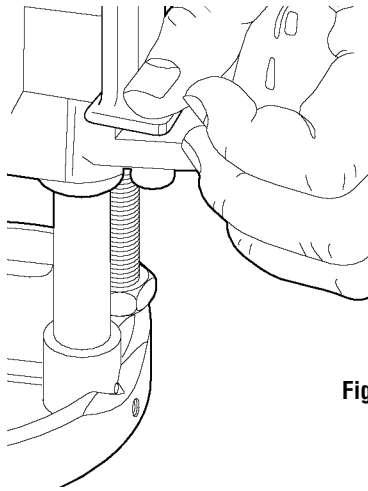

**Figure 13**

Always feed the router opposite to the direction in which the cutter is rotating.

Only carbide-tipped cutters should be used on panels faced with plastic laminates. The hard laminates will quickly dull steel cutters.

### **Direction Of Feed**

The direction of feed is very important when routing and can make the difference between a successful job and a ruined project. Figures 11 and 12 show proper direction of feed for some typical cuts.

Mold the outside edge of a piece of stock by a) mold the end grain, left to right, b) do the straight grain side moving left to right, c) finish the other end grain side, and d) do the remaining straight grain edge.

The direction of feed is important in router usage. Be sure the cutter is rotating into the stock by moving left to right on outside edges and clockwise on inside cuts.

### **Switch (Figure 13)**

TO SWITCH ON THE MACHINE

NOTE: Always pull the plug on the cord set out of its receptacle when changing a cutter or fitting the accessories in order to avoid any chance of an accident.

CONVENIENT SWITCH ACTUATOR PUSH UP FOR "ON" DOWN FOR "OFF".

### **Template Guide Adapter**

Your router comes equipped with a template guide adapter and two mounting screws. Put these away in a safe place for future use.

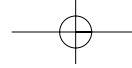

**Every B&D tool is of the highest quality.**  
**If you wish to contact us regarding this product, please call toll free between 8:00am and 8:00pm ET, seven days a week:**

**1-800-9-BD TOOL**  
**(1-800-923-8665)**

## **NOTES**

### **One Year Free Maintenance**

All B&D tools for Industry and Construction are covered under a one year free maintenance program where B&D will inspect your tool for safety and provide necessary maintenance or repairs, including normal wear and tear parts, for one year, FREE OF CHARGE.

### **Full Warranty**

All B&D tools for Industry and Construction are warranted to be free of any defects in materials or workmanship. Upon thorough examination of tool, B&D will repair or replace, at our option, any product that is determined to be defective.

### **Conditions**

The service/safety check and the warranty do not apply to: repairs made or attempted by anyone other than an authorized B&D service location; misuse, abuse, neglect, improper application of the tool; missing parts; or normal wear and tear (after first year of ownership). Please return the complete unit, transportation prepaid, to any B&D factory owned or B&D authorized service center location (list provided with tool or see Yellow Pages under "Tools Electric").

