

EluTM

WOODWORKING TOOLS BY
BLACK & DECKER

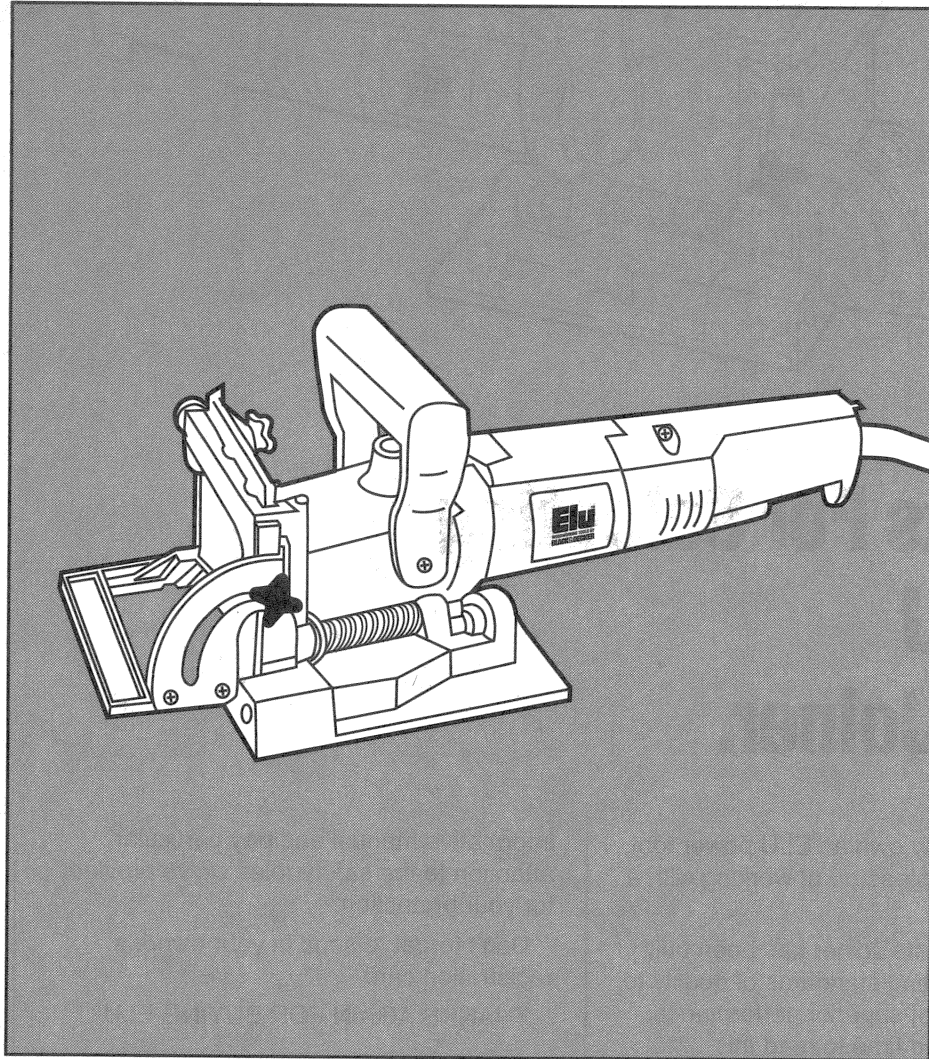

Instruction Manual
Plate Joiner
3379

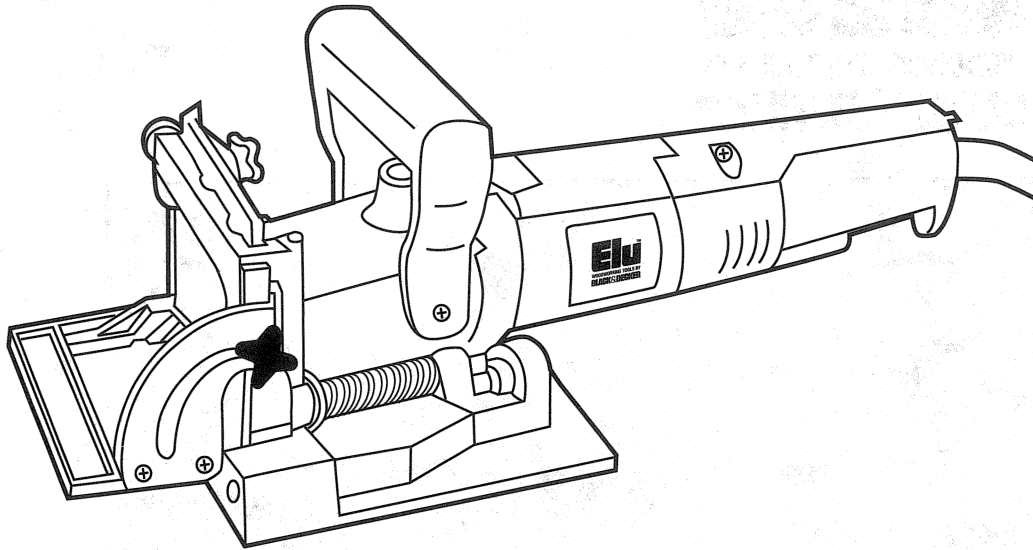

Thanks For Selecting An ELU Plate Joiner.

If you already own an ELU power tool, you know the pleasure of working with a real pro.

Your new Plate Joiner has been built to ELU's exacting standards of quality to ensure years of superior performance. Please take the time to read this

informative manual and pay particular attention to the safety rules we've provided for your protection.

Don't forget to send in your owner's registration card.

THANKS AGAIN FOR BUYING ELU!

ELUTM
WOODWORKING TOOLS BY
BLACK & DECKER

Important Safety Instructions

WARNING: When using electric tools, basic safety precautions should always be followed to reduce risk of fire, electric shock, and personal injury, including the following:

READ ALL INSTRUCTIONS

Double Insulation

Double insulated tools are constructed throughout with two separate layers of electrical insulation or one double thickness of insulation between you and the tool's electrical system. Tools built with this insulation system are not intended to be grounded. As a result, your tool is equipped with a two prong plug which permits you to use extension cords without concern for maintaining a ground connection.

NOTE: Double insulation does not take the place of normal safety precautions when operating this tool. The insulation system is for added protection against injury resulting from a possible electrical insulation failure within the tool.

CAUTION: WHEN SERVICING USE ONLY IDENTICAL REPLACEMENT PARTS. Repair or replace damaged cords.

Polarized Plugs

Polarized plugs (one blade is wider than the other) are used on equipment to reduce the risk of electric shock. When provided, this plug will fit into a polarized outlet only one way. If the plug does not fit fully into the outlet, reverse the plug. If it still does not fit, contact a qualified electrician to install the proper outlet. Do not change the plug in any way.

Safety Instructions For All Tools

- **KEEP WORK AREA CLEAN.** Cluttered areas and benches invite injuries.
- **CONSIDER WORK AREA ENVIRONMENT.** Don't expose power tools to rain. Don't use power tools in damp or wet locations. Keep work area well lit. Do not use tool in presence of flammable liquids or gases.
- **GUARD AGAINST ELECTRIC SHOCK.** Prevent body contact with grounded surfaces. For example; pipes, radiators, ranges, and refrigerator enclosures.
- **KEEP CHILDREN AWAY.** Do not let visitors contact tool or extension cord. All visitors should be kept away from work area.
- **STORE IDLE TOOLS.** When not in use, tools should be stored in dry, and high or locked-up place — out of reach of children.
- **DON'T FORCE TOOL.** It will do the job better and safer at the rate for which it was intended.
- **USE RIGHT TOOL.** Don't force small tool or attachment to do the job of a heavy-duty tool. Don't use tool for purpose not intended.
- **DRESS PROPERLY.** Do not wear loose clothing or jewelry. They can be caught in moving parts. Rubber gloves and non-skid footwear are recommended when working outdoors. Wear protective hair covering to contain long hair.
- **USE SAFETY GLASSES.** Also use face or dust mask if operation is dusty.
- **DON'T ABUSE CORD.** Never carry tool by cord or yank it to disconnect from receptacle. Keep cord from heat, oil, and sharp edges.
- **SECURE WORK.** Use clamps or a vise to hold work. It's safer than using your hand and it frees both hands to operate tool.
- **DON'T OVERREACH.** Keep proper footing and balance at all times.
- **MAINTAIN TOOLS WITH CARE.** Keep tools sharp and clean for better and safer performance. Follow instructions for lubricating and changing accessories. Inspect tool cords periodically and if damaged, have repaired by authorized service facility. Inspect extension cords periodically and replace if damaged. Keep handles dry, clean, and free from oil and grease.
- **DISCONNECT OR LOCK OFF TOOLS** when not in use, before servicing, and when changing accessories, such as blades, bits, cutters.
- **REMOVE ADJUSTING KEYS AND WRENCHES.** Form habit of checking to see that keys and adjusting wrenches are removed from tool before turning it on.
- **AVOID UNINTENTIONAL STARTING.** Don't carry tool with finger on switch. Be sure switch is off when plugging in.
- **EXTENSION CORDS.** Make sure your extension cord is in good condition. When using an extension cord, be sure to use one heavy enough to carry the current your product will draw. An undersized cord will cause a drop in line voltage resulting in loss of power and overheating. The following table shows the correct size to use depending on cord length and nameplate ampere rating. If in doubt, use the next heavier gage. The smaller the gage number, the heavier the cord.

Volts	Minimum Gage for Cord Sets			
	Total Length of Cord in Feet			
120V	0-25	26-50	51-100	101-150
240V	0-50	51-100	101-200	201-300
Ampere Rating				
More Than	Not more Than	American Wire Gage		
0	6	18	16	16
6	10	18	16	14
10	12	16	16	14
12	16	14	12	Not Recommended

- **OUTDOOR USE EXTENSION CORDS.** When tool is used outdoors, use only extension cords intended for use outdoors and so marked.
- **STAY ALERT.** Watch what you are doing. Use common sense. Do not operate tool when you are tired.
- **CHECK DAMAGED PARTS.** Before further use of the tool, a guard or other part that is damaged should be carefully checked to determine that it will operate properly and perform its intended function. Check for alignment of moving parts, binding of moving parts, breakage of parts, mounting, and any other conditions that may affect its operation. A guard or other part that is damaged should be properly repaired or replaced by an authorized service center unless otherwise indicated elsewhere in this instruction manual. Have defective switches replaced by authorized service center. Do not use tool if switch does not turn it on and off.

SAVE THESE INSTRUCTIONS

Introduction

Examine Figure 1 and your Plate Joiner for a few minutes to become familiar with the various features and the names used to describe them. The following sections will discuss the various controls and you will need to know where they are.

Overview

You have purchased a precision woodworking tool. The function of the Plate Joiner is to enable you to make extremely strong and accurate joints in wood and wood byproducts.

The tool works by a plunging action to precisely cut crescent shaped slots for the placement of flat wooden dowels or "biscuits" like those shown in Figure 2.

The various adjustments on the patented base/fence assembly will enable you to make virtually any biscuit joint imaginable. The tool

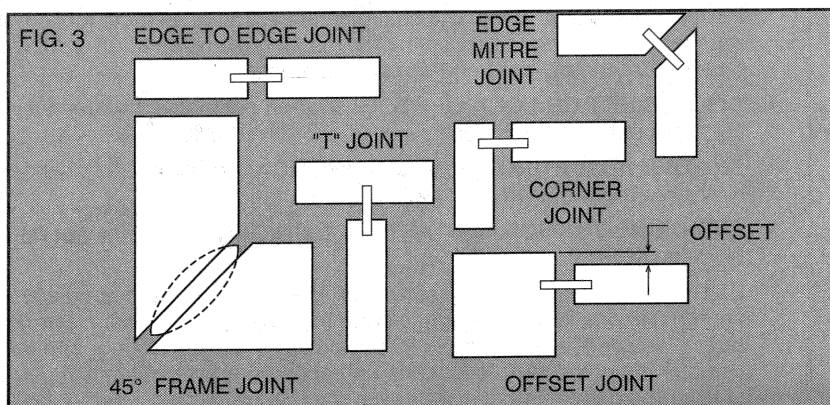
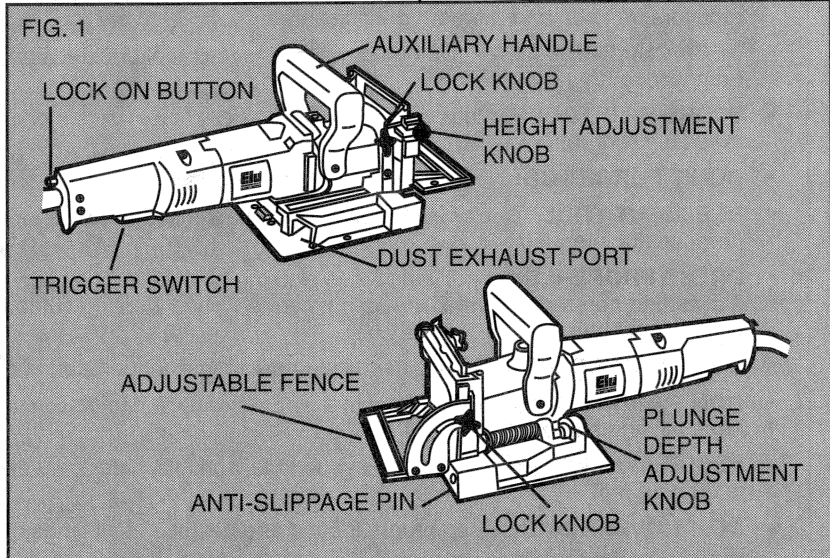
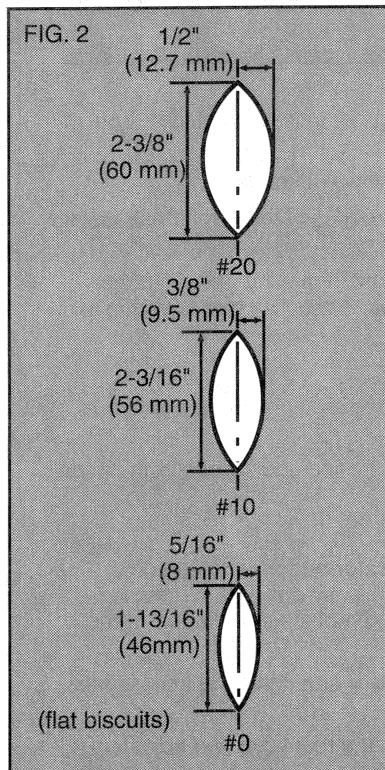

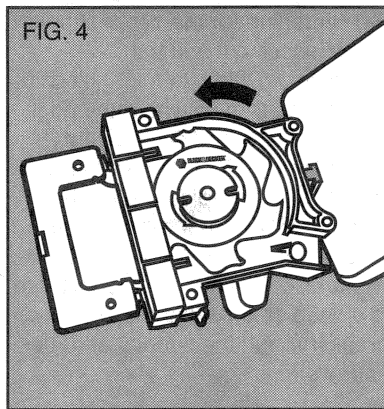

may be further enhanced by some simple jigs and fixtures that can be easily made. Some of the more common biscuit joinery applications are shown in Figure 3 and are discussed in detail in the applications section of this manual.

Form the habit of thinking through each operation before you perform it. This will result in a better job and will help you avoid any unexpected situations.

Switch

Your Plate Joiner has a trigger switch located on the underside, as shown in Figure 1. To turn the tool on, depress the trigger. To turn the tool off, release the trigger. To lock the tool on for continuous operation, there is a "Lock On" button located at the rear of the tool just above the cord. When cutting always hold the tool with one hand on the switch handle and one hand on the auxiliary handle. To lock the tool on, depress and hold the trigger as you depress the lock button. Hold the lock button in as you gently release the trigger. The tool will continue to run. To turn the tool off from a locked on condition, depress and release the trigger once.

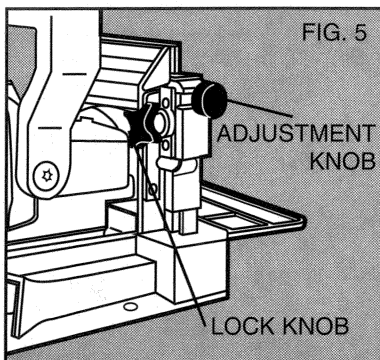

Blade Replacement

In time your saw blade will wear out and need replacement. To remove the blade, follow the steps below.

1. Turn off and unplug the Plate Joiner.
2. Remove the 4 torx head screws from the bottom of the shoe, using the T20 torx screwdriver provided.
3. Rotate the shoe out of the way.
4. Use the spanner wrench provided to loosen (counter clockwise) the blade nut. Depress the spindle lock pin on the top of the gear case to hold the spindle while you unscrew the nut.
5. Remove the blade and have it sharpened or replace it with a new one.
6. Reinstall the blade by reversing the steps above. Be sure blade teeth point counterclockwise as shown in Figure 4.
7. **IMPORTANT:** Always check the fine depth adjustment when sharpening or replacing the blade. Adjust if necessary. (See "Controls" section).

The Controls

The heart of your Plate Joiner is the base/fence assembly. All of the controls that let you make a variety of precision cuts are located on this assembly. Take a few minutes to become familiar with the various controls.

ALWAYS TURN OFF AND UNPLUG THE PLATE JOINER BEFORE MAKING ANY ADJUSTMENTS.

1. ADJUSTABLE FENCE

The adjustable fence provides a

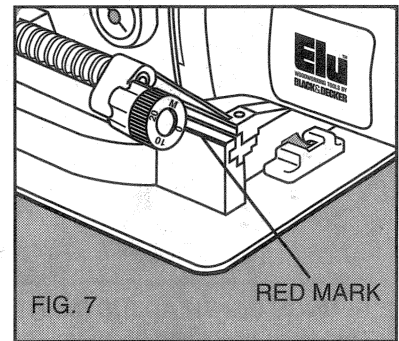
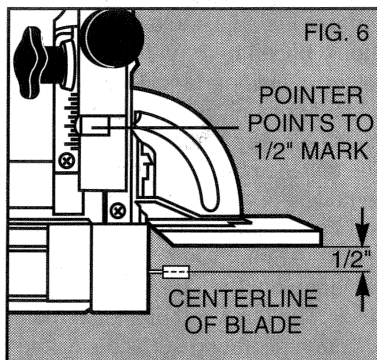

sturdy, precise reference surface to determine the point at which the slots for the biscuits will be cut. Its adjustable height feature allows you to position biscuit slots as close as 3/16" (4.76mm) and as distant as 1-3/8" (35 mm) measured from the workpiece surface to the centerline of the blade (See Figure 6). The adjustable angle feature allows a full range of settings from 0° to 90° as well as a reverse 45° bevel which

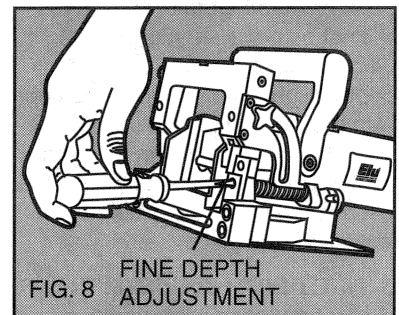

allows outside registration on miter joints. (See Applications section under Miter Joints, Figure 26).

The height adjustment is accomplished by first loosening the lock knob on the right side of the fence and then rotating the knurled adjustment knob until the desired height is reached. (See Figure 5).

Tightening the lock knob will then automatically align the fence parallel to the blade and lock it in position. The vertical scale and pointer located directly under the lock knob can be used to assist in setting this height. The scale readings indicate distance from the blade centerline to the fence surface when the fence is set at 90°. (See Figure 6). The fence angle can be set simply by loosening the lock knob on the left side of the tool, aligning the protractor scale with the pointer and tightening the lock knob.

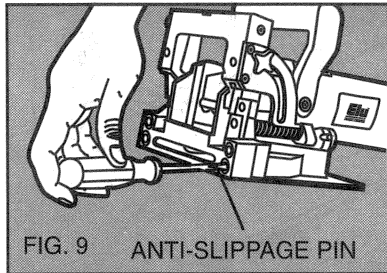

2. PLUNGE DEPTH ADJUSTMENT

The depth of cut can be set to match the dimensions of the particular size biscuit you will be using. The numbers on the depth adjustment knob (0,10,20,M) coincide with the three sizes of biscuits shown in Figure 2. The letter 'M' stands for the maximum depth capacity of the tool which is 20mm (25/32"). This depth is obtainable only with a new blade and by backing out the fine adjustment screw (see next section). NOTE: The 'M' setting has been provided for future use and will not be necessary for most biscuiting operations. To select a depth, align the appropriate number with the red mark scribed in the tool's housing, as shown in Figure 7. Rotate the depth adjustment knob to the desired position and it will "click" into place.

3. FINE DEPTH ADJUSTMENT

You may encounter situations where you want to leave a little looseness in your joint so that you can move it slightly before the glue sets up. For these instances a fine depth adjustment has been provided. To adjust, you must first raise the adjustable fence to its uppermost position. Then insert the T20 torx screwdriver provided into the opening as shown in Figure 8. Turn the depth

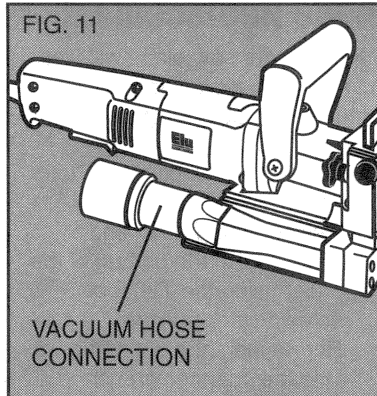
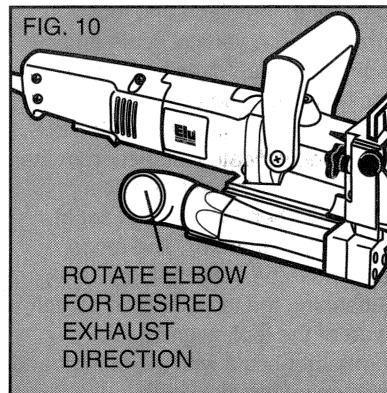

adjustment screw clockwise for less depth and counterclockwise for increased depth. Each full turn causes a change in depth of 1mm (0.040"). Always check the depth adjustment by first making test cuts in scrap wood.

4. ANTI-SLIPPAGE PINS

Plate Joiners tend to slide to the right with respect to the workpiece when making a cut. This tendency is increased with a dull blade or when plunging very rapidly. Anti-slippage pins have been provided to reduce this tendency and are located on the front registration surface on either side of the blade opening slot. When making some joints, you may wish to retract the anti-slippage pins so as not to scratch your workpiece in a visible area. For this purpose, simply rotate the anti-slippage pins approximately 1/6 of a turn and they will retract back behind the front registration surface. A flat blade screwdriver can be used to rotate the pins as shown in Figure 9.

5. BOTTOM REGISTRATION SURFACE

For certain applications, you will want to use the bottom surface of the Plate Joiner for alignment. When using the bottom registration surface, the adjustable fence should be set to 0° and the height setting is unimportant. This surface is used primarily when making 'T' joints (see Applications section). The distance between the centerline of the blade and the bottom registration surface is fixed at 3/8" (9.5mm) which allows centering on 3/4" (19mm) thick stock. The three red marks on the bottom registration surface indicate

the centerline (or the deepest point) of the biscuit cut and the approximate width of a #20 biscuit so that you'll know where the edge of the blade is and can prevent breakthrough. To avoid breaking through the workpiece, align the shoe so that neither outside mark extends beyond the end of the workpiece. If either side does, there is a good chance that the blade will break through the surface and ruin your work.

6. DUST EXTRACTION

There are three options provided for collecting dust from your Plate Joiner as described below.

- A. Adjustable Direction Elbow (See Figure 10). This attachment inserts into the dust exhaust port on the right side at the rear of the base assembly and clicks into place. To remove, pull out firmly. The directional elbow rotates easily to aim the dust in the most convenient direction suitable for the particular application.
- B. Dust Adaptor (See Figure 11). This attachment, when inserted as described above, allows the use of several common sizes of vacuum hose to be attached for direct vacuum pick-up of the dust.
- C. Dust Bag (See Figure 12). The dust bag provided fits snugly over the dust adaptor described above. To empty the bag, open the zipper underneath and dump dust out. NOTE: When the bag becomes full, the dust will back-up into the adaptor and the exhaust port on the right rear of the tool. To clean out, turn off and unplug the tool and remove packed dust. The bag will hold the dust generated from

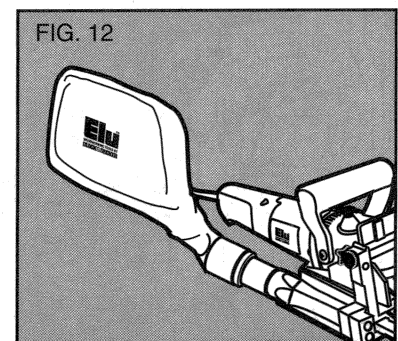

approximately 70 to 100 #20 biscuit cuts before filling up.

General Operation

Plate Joiners are primarily used for making cabinetry and furniture, joining millwork or other similar applications where a strong, accurate joint is required in wood or wood by products. There are literally hundreds of variations of joints that can be made with your Plate Joiner. We will limit our discussion to six basic joints that can be used to build on and adapt to your own applications. The following are some basic set-up steps that will apply to all biscuit joints.

1. BISCUIT SIZE ELECTION

As mentioned earlier, the three biscuit sizes are #0, #10 and #20. It is a good rule of thumb to use the largest biscuit size that will physically fit in the application. Unless you are joining narrow face or picture frames or using 1/2" or thinner stock, you will find the #20 biscuit size to suit most applications. After selecting the biscuit size, set the depth adjustment knob to the corresponding size (see Controls

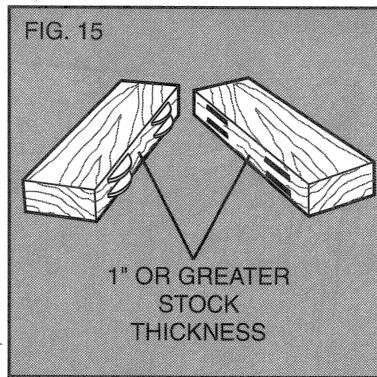
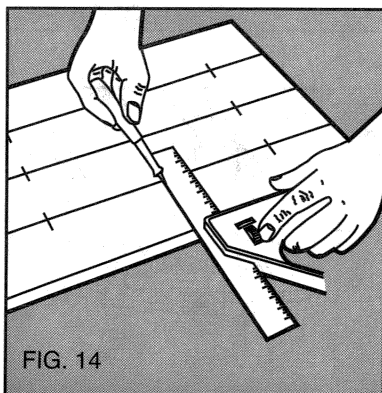
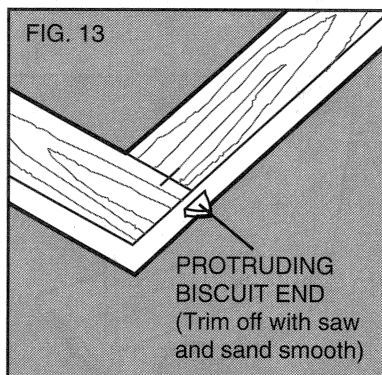

section). Also, be sure the fine depth adjustment is correctly set by first testing in a scrap piece. This is extremely important as you do not want to discover during glue-up that your biscuit slots are not quite deep enough.

2. BISCUIT LOCATION AND LAYOUT

Generally, biscuits may be spaced and located at your discretion. For edge joints, a good rule of thumb is to space biscuits every 6-10 inches on center. It is further recommended that biscuits be placed so that the centerline of the end biscuits is 2-3 inches from the end of the workpiece. When joining face frames or picture frames where the workpiece is narrow, you may have to choose the smaller biscuit sizes to keep from "breaking out" on the end of the joint. Breaking out should be avoided if possible, but if not you can assemble the joint and trim off the exposed biscuit tip after the glue sets. (See Figure 13). When working with material up to 1" thick, we advise to use a single biscuit located in the approximate center of the material thickness. If thicker stock is to be joined, you may choose to use 2 biscuits across the thickness for greater strength. (See Figure 15). Biscuit locations should be marked by first positioning the mating pieces exactly as they are to be assembled. Next, make a mark at 90° to the joint interface across both pieces at the desired biscuit locations. (See Figure 14). See Applications section for more specific information on joint layout. The marks you make will then be aligned with one of the center registration marks on the tool,

again, depending upon your specific application.

3. MAKING THE CUT

Prior to making any cut, be sure that all fence adjustments are set and lock knobs are tight. Also, be sure you have selected the proper depth setting. Clamp your workpiece firmly and align the Plate Joiner's center registration mark with your layout mark. Grasp the switch handle and auxiliary handle. Turn on the tool and let the blade come up to full speed (approximately 1 second). Position the fence firmly and squarely against the workpiece, and plunge the blade until it bottoms against the stop. Continuing to hold the tool squarely and firmly, allow the return spring to retract the blade from the work and then release the switch to shut the tool off. It will take some practice to obtain a "feel" for the tool to produce accurate joints, so practicing in scrap wood first is advisable.

4. JOINT ASSEMBLY

After your joints are cut, you may wish to trial fit everything together before gluing. When you are satisfied with your joints, evenly spread any good quality wood-working glue in each slot as well as on the mating flat surfaces of your joint. Place biscuits in the slots, assemble the joint and clamp until dry. For a biscuit joint to be most effective, it is important that the biscuits themselves be in contact with the glue. This is because the biscuits absorb the moisture in the glue and expand to form a tight joint.

Applications

1. EDGE TO EDGE JOINTS (SEE FIGURE 16)

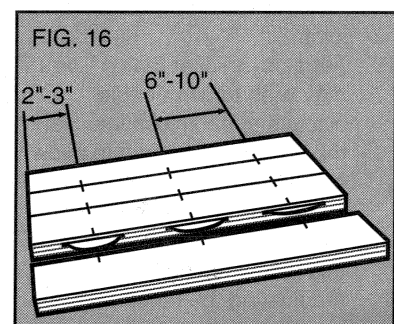

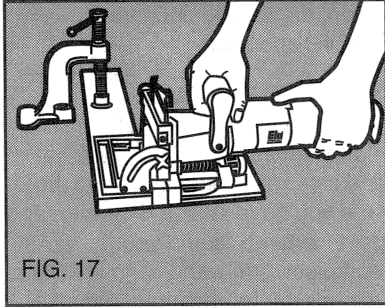

FIG. 17

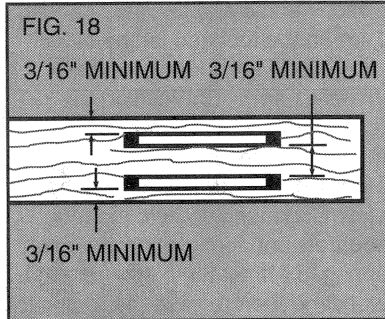

FIG. 18

This is the simplest to make and most common joint for the Plate Joiner. Follow the steps below to produce this joint.

- A. Prepare the workpieces and lay them on a work surface exactly as they are to be assembled.
- B. Spacing biscuits 2-3" in from the ends and 6-10" apart, lay out the biscuit centers.
- C. Set up the Plate Joiner by first selecting the proper depth setting. Set the fence to 90°. Set the height adjustment to position the biscuit in the approximate center of the stock thickness.
- D. Clamp the workpiece and position the tool so that the center indicator mark lines up with the first layout mark. (See Figure 17). Turn on the tool and make the plunge cut. Retract the tool and release the trigger to turn the tool off. Repeat for each layout mark.
- E. Glue, assemble and clamp the joint.
- F. For stock thicker than 1", you may wish to use double biscuits at each location. Set the height adjustment to allow at least 3/16" of stock between the biscuit and the edge of the work surface. Make all cuts at this fence setting before readjusting the fence for the

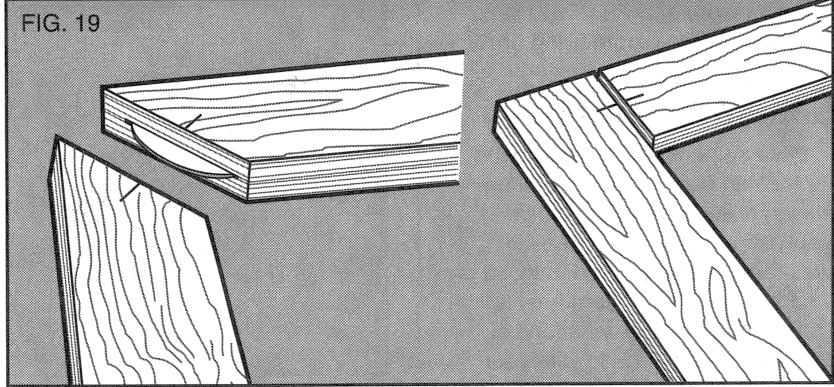

FIG. 19

lower cuts. Again, there should be at least 3/16" of stock between the biscuit and the outside wall and between the biscuits themselves. (See Figure 18).

2. FRAME JOINTS (SEE FIGURE 19)

Frame joints are an ideal application for biscuit joinery. With the Plate Joiner you can create a very strong, precise joint that is much faster to make than a dowel or mortise and tenon joint. Figure 19 shows two types of frame joints. Follow the steps outlined below.

- A. Arrange the workpieces on a flat work surface exactly as they are to be assembled.
- B. Select the proper biscuit size based on the length of the joint. (If the frame pieces are too narrow for a #0 biscuit, you will have to allow the biscuit tip to protrude slightly and then trim it off after the joint is dry. (See Figure 13).
- C. Lay out the biscuit locations.
- D. Set up the tool by selecting the depth that corresponds to the chosen biscuit size. Lock the fence at 90° and adjust the fence height to center the biscuit on the stock thickness.
- E. Clamp the workpiece and position the Plate Joiner to

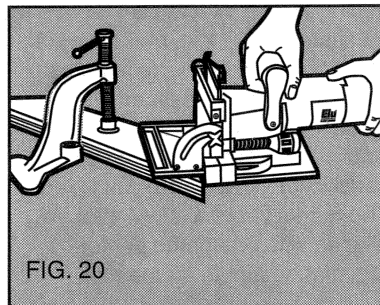

FIG. 20

make the first cut. (See Figure 20).

- F. Turn on the tool and make the plunge cut.
- G. Repeat for each layout mark.
- H. Glue, assemble and clamp the frame.

3. CORNER JOINTS (SEE FIGURE 21)

Corner joints are another common and excellent application for biscuit joinery. Follow the procedure below.

- A. Arrange the workpieces exactly as they are to be joined.
- B. Select the biscuit size and lay out the biscuit locations.
- C. Set up the tool by selecting the proper depth setting, adjusting the fence to center on the stock thickness and setting the angle to 90°.

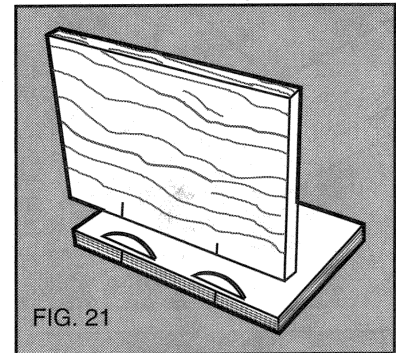

FIG. 21

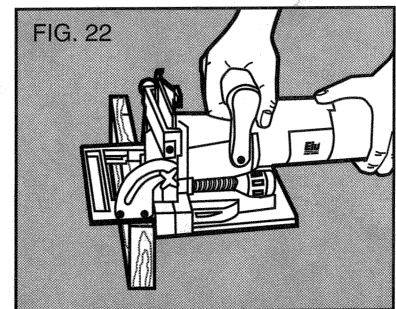

FIG. 22

- D. For this joint, you will make cuts into the edge of one workpiece and the face of another. The edge cut is performed the same as for edge to edge joints. The face cut is made by clamping the workpiece and aligning the tool as shown in Figure 22. Turn the tool on, make the plunge cut and repeat for each layout mark.
- E. Glue, assemble and clamp the joint.

4. OFFSET JOINTS (SEE FIGURE 23)

You may wish to have a deliberate offset between two workpieces. This is easily accomplished with your Plate Joiner by performing the following steps.

- A. Arrange the workpieces as they are to be assembled and lay out the biscuit locations.
- B. Set up the tool by selecting the proper biscuit size and adjusting the fence angle to 90°. Select the workpiece that will be set back and adjust the fence height to center the cut within the thickness of that piece.
- C. Clamp the workpiece, align the tool and make the plunge cut.
- D. Next, adjust the fence up by an amount equal to the desired offset. Use the scale and

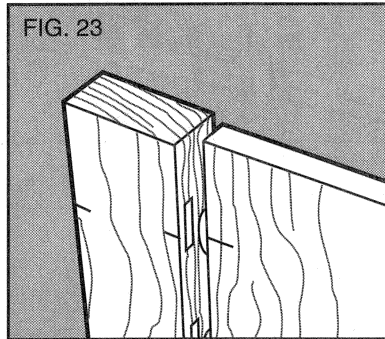

- pointer located on the right side of the tool under the fence lock knob.
- E. Clamp the second workpiece, align the tool and make the plunge cut.
- F. Glue, assemble and clamp the joint.

5. EDGE MITER JOINTS (SEE FIGURE 24)

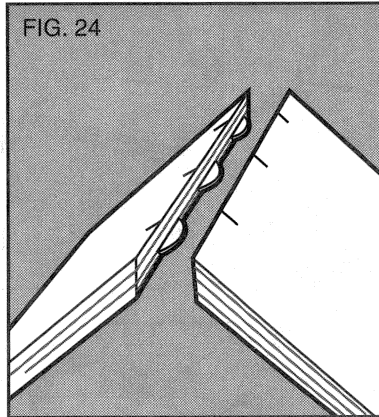

Edge miters are most commonly used in box structures or for making multi-sided pedestals where you would like to hide the end grain. Once again, biscuit joinery is an outstanding method to use both for added strength as well as ease of assembly. Follow the steps below to assemble a 90° joint.

- A. Position the workpieces as they are to be assembled and lay out biscuit locations on the outside of the joint.
- B. Set up tool by first setting the fence angle to 90°. Make the fence adjustment such that the biscuit is located toward the inside of the joint where the material is thicker, then select the biscuit size so that the blade does not protrude through the outside wall when the cut is made. (See Figure 25).
- C. Clamp the workpiece and align the tool as shown in Figure 26.
- D. Turn on the tool and make the plunge cut.
- E. Glue, assemble and clamp the joint.
- F. For joints other than 90° see outside registration column in Figure 27 for proper fence angle setting.

The above method will produce a joint where the outside surfaces of the joint are aligned. If you wish to produce a joint where the inside surfaces are aligned, use the following procedures for a 90° joint.

- A. Position workpieces as they are to be assembled.
- B. Lay out biscuit locations on the inside of the angle.
- C. Set up tool by setting fence angle to 45°. Set vertical fence adjustment so that the biscuit is

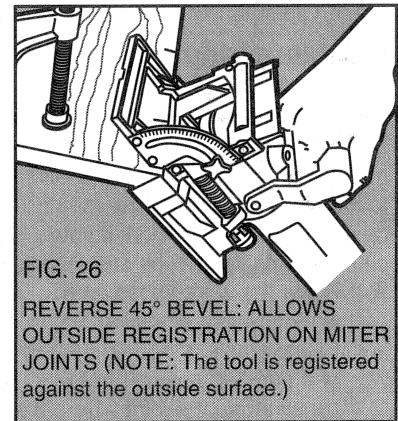
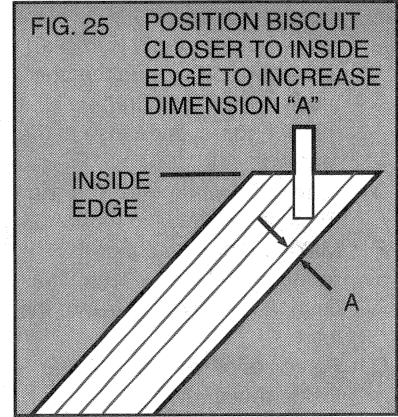
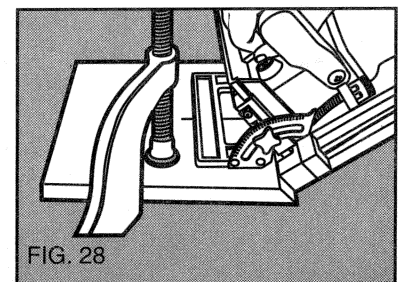

FIG. 27

# OF SIDES	JOINT ANGLE	FENCE ANGLE SETTING	
		OUTSIDE REGISTRATION	INSIDE REGISTRATION
4	90°	90°	45°
5	108°	81°	54°
6	120°	75°	60°
8	135°	67.5°	67.5°



located toward the inside of the joint where material is thicker. Select biscuit size so that the blade does not protrude through the outside face of the material.

- D. Clamp the workpiece and align the tool as shown in Figure 28.
- E. Make the plunge cut and repeat for all biscuit locations.
- F. Glue, assemble and clamp the joint.
- G. For joints other than 90° see inside registration column in Figure 27 for proper fence angle setting.

6. T-JOINTS (FIGURE 29)

Biscuit joining is a viable alternative to dadoing when making a T-joint. T-joints are most commonly used when attaching shelves to the sides of a case. The method described below will work if your shelf material is at least 5/8" thick.

- A. Place the workpieces on a work surface exactly as you will be assembling them in the form of an upside down "T." Mark lightly along the joint where the top of the shelf is to end up (See Figure 30). Mark biscuit locations at the joint interface on the shelf piece only.
- B. Lay the shelf down on the mating workpiece. Clamp the two workpieces together and to the work surface in this position (See Figure 31).
- C. Set up the tool by selecting the proper biscuit size and setting the adjustable fence angle at 0°.
- D. Using the bottom registration surface, align the tool with the biscuit location marks and make a vertical and a horizontal plunge cut for each biscuit location as shown in Figure 32.
- E. Glue, assemble and clamp the joint.

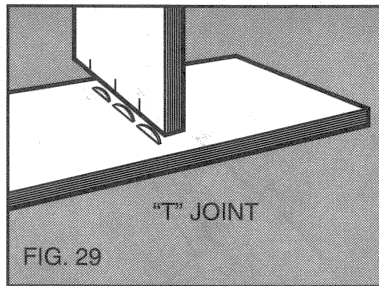

FIG. 29

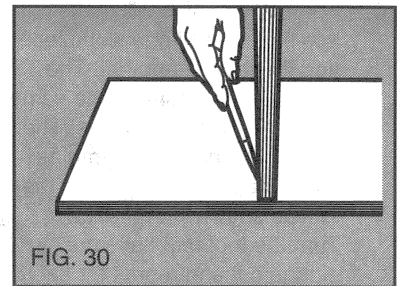

FIG. 30

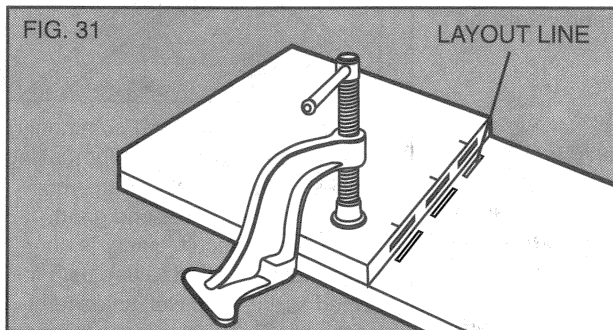

FIG. 31

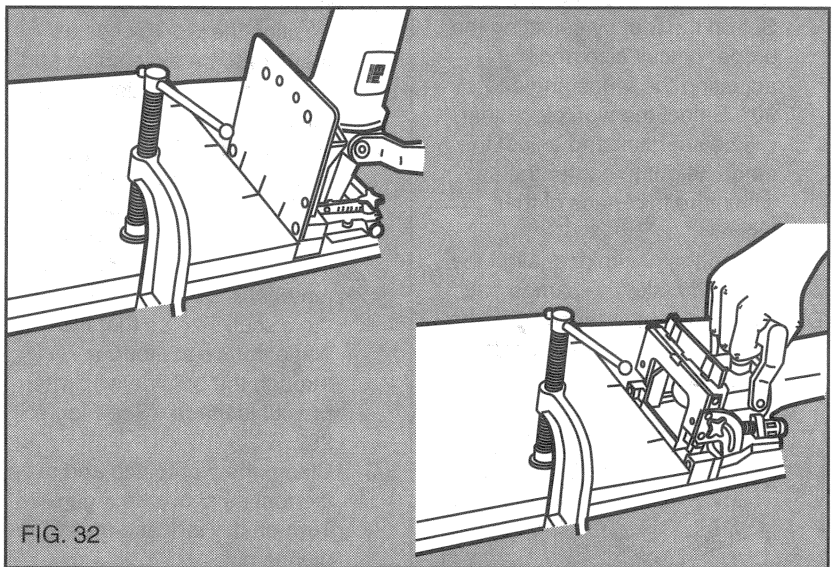

FIG. 32

Notes

Important

To assure product SAFETY and RELIABILITY, repairs, maintenance, and adjustment should be performed by Black & Decker (U.S.) Inc. industrial service centers or other qualified service organizations. These service organizations service ELU tools always using ELU replacement parts.

Accessories

Recommended accessories for use with your tool are available at extra cost from your local dealer or service center.

A complete listing of service centers is included on the owner's registration card packed with your tool.

If you need assistance in locating any accessory, please contact Black & Decker (U. S.) Inc., Consumer Service Department, P.O. Box 626 Hanover Pike, Hampstead, MD 21074.

Full Warranty

ELU warrants this tool for one year from date of purchase. We will repair, without charge, any defects due to faulty materials or workmanship. Please return the complete unit, transportation prepaid, to any Black & Decker (U.S.) Inc. industrial service center or authorized service station listed under "Tools, Electric" in the yellow pages. This warranty does not apply to accessories or damage caused where repairs have been made or attempted by others. This warranty gives you specific legal rights and you may have other rights which vary from state to state.

Every Black & Decker tool is of the highest quality. If you wish to contact us regarding this product, please call toll free between 8:00 a.m. and 8:00 p.m. ET, seven days a week.

1-800-762-6672



See 'Tools-Electric'
– Yellow Pages –
for Service & Sales

ELUTM
WOODWORKING TOOLS BY
BLACK & DECKER

Form No. 158992-01
Printed in U.S.A.

(APR95-CD-4) Copyright © 1992, 1995 Black & Decker
BLACK & DECKER (U.S.) Power Tools Group 701 E. Joppa Road, Towson MD 21286 U.S.A.