

Master

SERIES
by BLACK&DECKER®

NEW! **5590 5000 RPM 7"/9" Angle Grinder**
5591 6000 RPM 7"/9" Angle Grinder:
Premium quality large angle grinders designed to work with 7" and 9" grinding wheels and backing pads for grinding and sanding in the most demanding applications.

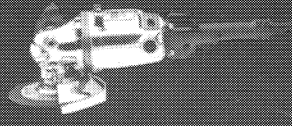

NEW! **5580 4 1/2" Angle Grinder:**
Premium quality small angle grinder for grinding and sanding for a variety of jobs.

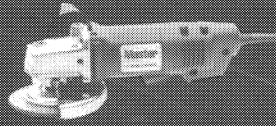

NEW! **5581 4 1/2" Angle Grinder Kit:**
The same high quality grinder as the 5580 with a metal kit box.

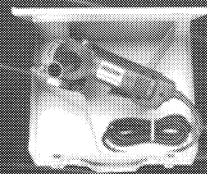

NEW! **5321 Variable-Speed Cut-Saw™ Reciprocating Saw:**
Premium quality saw with an easy-to-use thumb dial variable-speed control.

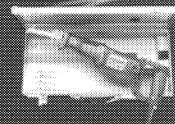

5111 Holgun® 3/8" VSR Drill:
Premium quality pistol-grip drill designed for long life in heavy-duty use in a variety of materials—wood, masonry and composites.



5130 Holgun® 1/2" VSR Drill:
Premium quality drill with maximum power for its compact size. Designed for drilling larger diameter holes with a no-load speed of 600 RPM.



5140 1/2" Spade Handle Drill:
Premium quality spade handle drill for the heaviest industrial and construction demands.

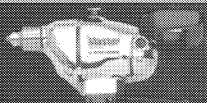

5274 Versa-Clutch® Scrugun® VSR Screwdriver:
Premium quality adjustable clutch screwdriver designed to drive a wide variety of fasteners to perfect tightness.



5158 Timberwolf™ 1/2" Right Angle Drill:
Premium quality drill designed for plumbers and electricians who need to drill large diameter holes in tight quarters.

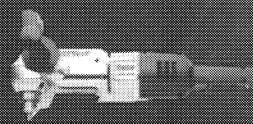

5159 Timberwolf™ 1/2" Right Angle Drill Kit:
The same quality drill as the 5158 with a metal kit box.



Black & Decker (U.S.) Inc.
10 North Park Drive
P.O. Box 798
Hunt Valley, Maryland
21030-0798

Form No. 741580-04
(SEP91-CD-1)
Copyright ©1991 Black & Decker
Printed in U.S.A.

Master

SERIES
by BLACK&DECKER®

Instruction Manual

5580
4 1/2" Angle Grinder
5581
4 1/2" Angle Grinder Kit

Masterpieces of Power and Performance



Finally, a small angle grinder designed to improve upon perfection.

Removable cord protector makes replacing the power supply cord fast and easy.

10 foot long rubber power supply cord provides extra length for ease of use and stays flexible at low temperatures.

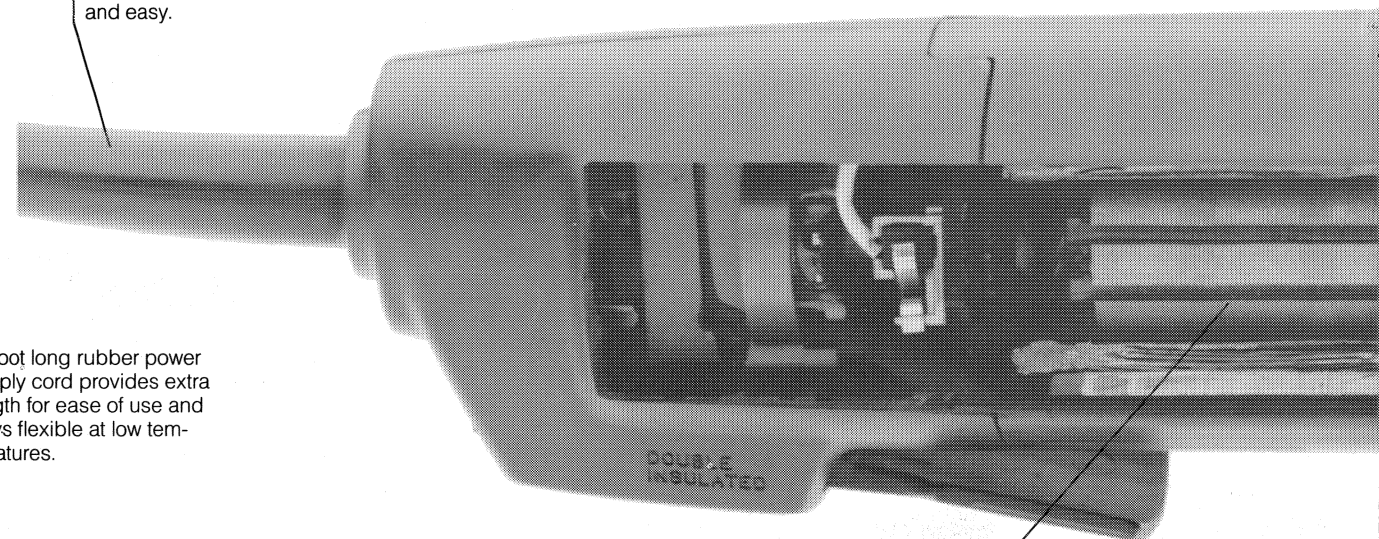

Powerful 6.5 amp Black & Decker built motor gives long service.

You're a pro. Proud of your work, always ready to take on a new challenge. Confident you'll do the best job possible.

With the new Master Series™ small angle grinder you can count on doing the job even better, because your new grinder is better than any you've used before. This model is designed specifically to handle 4½" grinding wheels and discs for grinding and sanding in the most demanding applications. This tool will exceed the durability requirements of your work environment.

The Master Series small angle grinder gives you more of what you want: more power, more performance. And gives it to you better. With better design, better parts and better service.

You get top performance with the reliable and powerful Black & Decker built motor.

You get more durability and quieter operation from the precision-engineered cut-steel spiral bevel gears.

You get an adjustable position wheel guard with the tool that complies with the ANSI safety code.

The polished gear case guarantees you superior quality inside and out.

Look at the other special features of your new Master Series grinder in the cutaway view we've provided.

Once you use your new Master Series grinder, we think you are going to agree Master Series tools are masterpieces of power and performance.

Size and dimensional clearances:

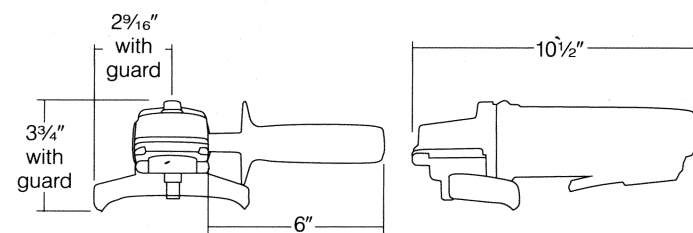

Available accessories:

Black & Decker's complete line of grinding and sanding accessories.

Extension Cords

Tools that have 3-wire cords requiring grounding must only be used with extension cords that have 3-prong grounding type plugs and 3-pole receptacles. Only round jacketed extension cords should be used, and we recommend that they be listed by Underwriters Laboratories (U.L.) (C.S.A. in Canada). If the extension will be used outside, the cord must be suitable for outdoor use. Any cord marked as outdoor can also be used for indoor work. The letters "WA" on the cord jacket indicate that the cord is suitable for outdoor use.

An extension cord must have adequate wire size (AWG or American Wire Gauge) for safety, and to prevent loss of power and overheating. The smaller the gauge number of the wire, the greater the capacity of the cable, that is 16 gauge has more capacity than 18 gauge. When using more than one extension to make up the total length, be sure each individual extension contains at least the minimum wire size.

To determine the minimum wire size required, refer to the chart below.

CHART FOR MINIMUM WIRE SIZE (AWG) OF EXTENSION CORDS

NAMEPLATE RATING-AMPS	TOTAL EXTENSION CORD LENGTH-FEET							
	25	50	75	100	125	150	175	200
0 - 10.0	18	18	16	16	14	14	12	12
10.1 - 13.0	16	16	14	14	14	12	12	12
13.1 - 15.0	14	14	12	12	12	12	12	---

Before using an extension cord, inspect it for loose or exposed wires, damaged insulation, and defective fittings. Make any needed repairs or replace the cord if necessary. Black & Decker has extension cords available that are U.L. (C.S.A. in Canada) listed for outdoor use.

Caution

To assure product SAFETY and RELIABILITY, repairs, maintenance and adjustment should be performed by BLACK & DECKER Service Centers or other qualified service organizations, always using BLACK & DECKER replacement parts.

Warranty

Black & Decker (U.S.) Inc. warrants this product for one year from date of purchase. We will repair without charge, any defects due to faulty material or workmanship. Please return the complete unit, transportation prepaid, to any Black & Decker Service Center or Authorized Service Station listed under "Tools Electric" in the yellow pages. This warranty does not apply to accessories or damage caused where repairs have been made or attempted by others.

Every Black & Decker tool is of the highest quality. If you wish to contact us regarding this product, please call toll free between 8:00 a.m. and 5:00 p.m. EST, Monday through Friday. 1-800-762-6672

Like most Black & Decker products, your tool is listed by Underwriters Laboratories to ensure that it meets stringent safety requirements.

This symbol on the nameplate means the product is listed by Underwriter's Laboratories, Inc.



See 'Tools-Electric'
—Yellow Pages—
for Service & Sales

Notes

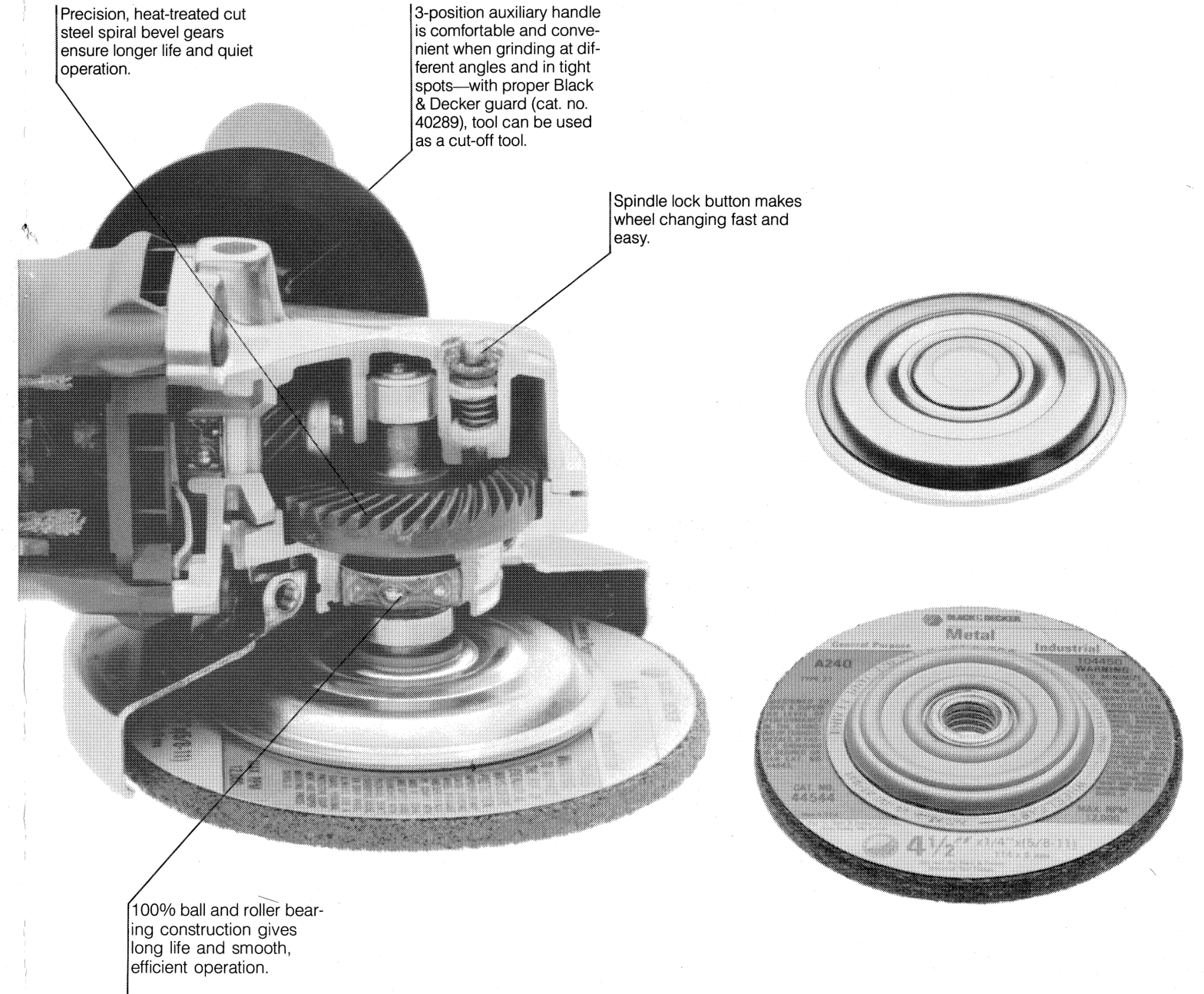

Specifications:

Wheel capacity (inches)	4½
Current rating @ 120V AC/DC (amps)	6.5
No load speed (rpm) (nominal)	10000
Speed at rated current (rpm)	7778
Maximum power output (watts/horsepower)	700/9
Power output @ rated current (watts/horsepower)	298/4
Maximum torque output (in. lb.)	37.6
Torque output at rated current (in. lbs.)	3.3
Overall gear reduction ratio	2.92:1
Spindle thread (inches)	5/8-11
Weight w/o guard (lbs.)	5580 3.75
Kit weight (lbs.)	5581 12.5
Shipping weight (lbs.)	5580 5.0
Shipping weight (lbs.)	5581 13.75

Commonly used service parts' numbers:

Power supply cord	448557-98
Separable cord protector	24288-00
Switch	445861-01
Brushes (2 required)	445861-00
Armature	447844-00
Field	445859-71

Standard Equipment:

5581 includes same equipment and metal kit box. Spindle nut and spanner wrench are included for your convenience.

Regulatory agency listing and compliance:

5580 and 5581 are U.L. listed and in compliance with OSHA.

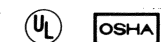

Important Safety Instructions (For All Tools)

WARNING: When using Electric Tools, basic safety precautions should always be followed to reduce the risk of fire, electric shock, and personal injury, including the following:

READ ALL INSTRUCTIONS

1. **KEEP WORK AREA CLEAN.** Cluttered areas and benches invite injuries.
2. **CONSIDER WORK AREA ENVIRONMENT.** Don't expose power tools to rain. Don't use power tools in damp or wet locations. Keep work area well lit.
3. **GUARD AGAINST ELECTRIC SHOCK.** Prevent body contact with grounded surfaces. For example: pipes, radiators, ranges, refrigerator enclosures.
4. **KEEP CHILDREN AWAY.** All visitors should be kept away from work area. Do not let visitors contact tool or extension cord.
5. **STORE IDLE TOOLS.** When not in use, tools should be stored in dry, and high or locked-up place—out of reach of children.
6. **DON'T FORCE TOOL.** It will do the job better and safer at the rate for which it is intended.
7. **USE RIGHT TOOL.** Don't force small tool or attachment to do the job of a heavy-duty tool. Don't use tool for purpose not intended, for example, don't use circular saw for cutting tree limbs or logs.
8. **DRESS PROPERLY.** Do not wear loose clothing or jewelry. They can be caught in moving parts. Rubber gloves and non-skid footwear are recommended when working outdoors. Wear protective hair covering to contain long hair.
9. **USE SAFETY GLASSES.** Also use face or dustmask if cutting operation is dusty.
10. **DON'T ABUSE CORD.** Never carry tool by cord or yank it to disconnect from receptacle. Keep cord from heat, oil, and sharp edges.
11. **SECURE WORK.** Use clamps or a vise to hold work. It's safer than using your hand and it frees both hands to operate tool.
12. **DON'T OVERREACH.** Keep proper footing and balance at all times.
13. **MAINTAIN TOOLS WITH CARE.** Keep tools sharp and clean for better and safe performance. Follow instructions for lubricating and changing accessories. Inspect tool cords periodically and if damaged have repaired by authorized service facility. Inspect extension cords periodically and replace if damaged. Keep handles dry, clean, and free from oil and grease.
14. **DISCONNECT TOOLS.** When not in use, before servicing, and when changing accessories, such as blades, bits, cutters.
15. **REMOVE ADJUSTING KEYS AND WRENCHES.** Form habit of checking to see that keys and adjusting wrenches are removed from tool before turning it on.
16. **AVOID UNINTENTIONAL STARTING.** Don't carry plugged-in tool with finger on switch. Be sure switch is off when plugging in.
17. **OUTDOOR USE EXTENSION CORDS.** When tool is used outdoors, use only extension cords intended for use outdoors and so marked. More detailed information can be found on page 11.
18. **STAY ALERT.** Watch what you are doing. Use common sense. Do not operate tool when you are tired.
19. **CHECK DAMAGED PARTS.** Before further use of the tool, a guard or other part that is damaged should be carefully checked to determine that it will operate properly and perform its intended function. Check for alignment of moving parts, binding of moving parts, breakage of parts, mounting and any other conditions that may affect its operation. A guard or other part that is damaged should be properly repaired or replaced by an authorized service center unless otherwise indicated elsewhere in this instruction manual. Have defective switches replaced by authorized service center. Do not use tool if switch does not turn it on and off.
20. **DO NOT OPERATE** portable electric tools near flammable liquids or in gaseous or explosive atmospheres. Motors in these tools normally spark, and the sparks might ignite fumes.

SAVE THESE INSTRUCTIONS FOR FUTURE USE.

Wire Cup and Knotted Wire Wheel Brushes

1. Be sure tool is disconnected from power supply and switch is in "OFF" position. Rest grinder on its back with spindle facing up.
2. Ensure that the rated speed of the wire brush is equal to or higher than 12,000 RPM.

3. REMOVE THE UNIVERSAL TOOL FLANGE SHOWN IN FIGURE 4. SAVE THIS PART FOR FUTURE USE. This part cannot be used with Wire Brushes.
4. Thread brush onto spindle and tighten.
5. Common applications for wire brushes include cleaning welds, angles, corners and rust removal.

Accessories

The accessories listed in this manual are available at extra cost from your local dealer or Black & Decker Service Center. A complete listing of service centers is included on the owner's registration card packed with your tool.

If you need assistance in locating any accessory, please contact: Black & Decker (U.S.) Inc., User Services Department, 626 Hanover Pike, P.O. Box 618, Hampstead, MD 21074-0618.

CAUTION: The use of any accessory or attachment other than those recommended in this manual may be hazardous.

Accessory Type	Notes	Usages
* DEPRESSED CENTER WHEELS	USE GUARD SUPPLIED WITH TOOL	Use for moderate metal & masonry removal on flat or contoured surfaces.
SANDING DISCS		Use for smoothing welds, and sharp edges, and automotive body work.
WIRE BRUSHES	MAX. 4" KNOTTED WHEEL MAX. 2 3/4" CUP WHEEL	Use for rust removal and surface preparation before painting.

* Depressed Center Grinding Wheels must fit within the confines of the guard.

WARNING—To reduce the risk of injury, always use proper guards when grinding and wear eye protection.

Your Grinder can operate with the following accessories which are rated at or above 12,000 RPM.

- All Black & Decker 4" & 4 1/2" diameter Depressed Center Grinding Wheels.
- All Black & Decker 4" & 4 1/2" Sanding Discs, Backing Pads & Backing Flanges.
- All Black & Decker Crimped Wire Cup Brushes, Knotted Wire Cup Brushes & Knotted Wire Wheels

Maintenance of Tool Cleaning

Blowing dust and grit out of the motor housing using compressed air is a necessary regular maintenance procedure. Dust and grit containing particles from metal grinding often accumulate on interior surfaces and could create an electrical shock hazard if not frequently cleaned out.

CAUTION: Never use solvents or other harsh chemicals for cleaning the non-metallic parts of the tool. Use clean, dry rag only.

Lubrication

B&D tools are properly lubricated at the factory and are ready for use. Tools should be relubricated regularly every sixty days to six months, depending on usage. (Tools used constantly on production for heavy-duty jobs and tools exposed to heat may require more frequent lubrication.) This lubrication should only be attempted by trained power tool repairpersons such as those at B&D Service Centers or in other qualified service organizations.

Motor Brushes

Your tool is equipped with the Black & Decker Checkpoint™ Brush System. When the brushes become worn out, the tool will automatically stop and prevent damage to the motor. Brush replacement should be performed by Black & Decker service centers or other qualified service organizations.

Removal of Fiber Backing Disc and Sanding Disc

1. Be sure tool is disconnected from power supply and switch is in "OFF" position.
2. Depress the spindle lock pin to lock the spindle. Using a cloth or glove to protect your hand, grasp the sanding disc and fiber backing disc and turn in the direction of the sanding direction arrow as indicated on tool until sanding disc loosens. Remove used sanding disc. See Figure 7.

Sanding Operation

When using a sanding disc, hold the tool so that an angle of 10° to

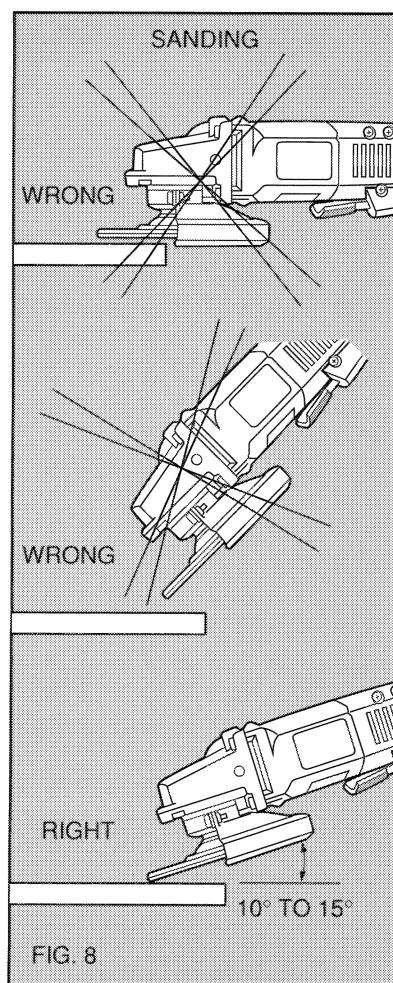

15° exists between the disc and the work, as shown in Figure 8. If only the outer edge of the sanding disc is used, a rough cut surface will result. If the sanding disc is pressed flat against the work the sanding action will be irregular and bumpy, and the tool will be difficult to control.

Using Wheelfast™ Rubber Backing Pad Sanding Accessory

Black & Decker accessory catalog number 54641 (not included with unit).

Installation of Wheelfast™ Rubber Backing Pad and Sanding Discs

1. Be sure tool is disconnected from power supply and switch is in "OFF" position.
2. Install the Wheelfast rubber backing pad. Install the sanding disc and Wheelfast™ clamp washer. (Wheelfast™ clamp washer included with cat. no. 54641 Backing Pad.)
3. Depress the spindle lock pin to lock the spindle. Grasp the sanding disc and the Wheelfast™ rubber backing pad and turn until the Wheelfast™ clamp washer is tight. See Figure 6.

Removal of Wheelfast™ Rubber Backing Pad and Sanding Disc

1. Be sure tool is disconnected from power supply and switch is in "OFF" position.
2. Depress the spindle lock pin to lock the spindle.
3. Using a cloth or glove to protect your hand, grasp the sanding disc and the Wheelfast™ rubber backing pad and turn in the direction of the sanding direction arrow as indicated on tool until sanding disc loosens. Remove used sanding disc. See Figure 6.

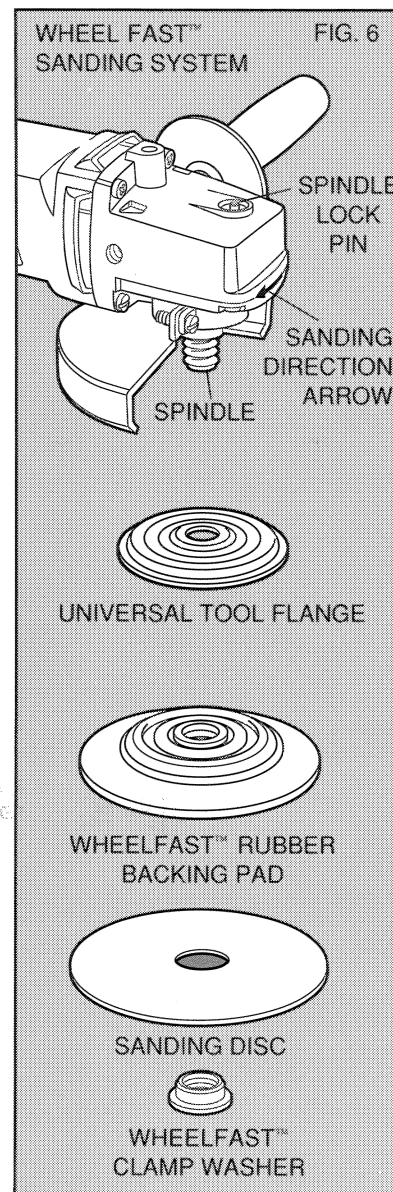

Safety Rules For Grinders

1. Always wear safety goggles or other eye protection when using this tool.
2. When grinding, always keep guard in place.
3. Use only rotating accessories, such as grinding wheels, sanding discs and wire brushes which are marked to show maximum safe RPM equal to or greater than the maximum RPM stated on the tool's nameplate. The 5580 Grinder discussed in this manual has an RPM statement on its nameplate that is explicit about the RPM of the accessories to use.

The nameplate on the 5580 Grinder says "DO NOT USE ACCESSORIES RATED LESS THAN 12,000 RPM".

4. Before using, inspect recommended accessory for cracks or flaws. If such a crack or flaw is evident—discard the wheel! The wheel should also be inspected whenever you think the tool may have been dropped.
5. When starting the tool (with a new or replacement wheel installed) hold the tool in a well protected area and let it run for one minute. If the wheel has an undetected crack or flaw, it should burst in less than one minute. Never start the tool with a person in line with the wheel. This includes the operator.
6. In operation, avoid bouncing the wheel or giving it rough treatment. If this occurs, stop the tool and inspect the wheel.
7. Always use guards with abrasive wheels and discs.
8. Clean your tool out periodically following the procedure in the maintenance section.

SAVE THESE INSTRUCTIONS

Grounding

This tool should be grounded while in use to protect the operator from electric shock. The tool is equipped with an approved three-conductor cord and three prong

grounding type plug to fit the proper grounding type receptacle. The green (or green and yellow) conductor in the cord is the grounding wire. Never connect the green (or green and yellow) wire to a live terminal. Your unit is for use on less than 150 volts and has a plug like that shown in Figure A. An adapter, Figures B and C, is available for connecting Figure A plugs to two-prong receptacles. The green-colored rigid ear, lug, etc., must be connected to a permanent ground such as a properly grounded outlet box. **ADAPTOR SHOWN IN FIGURES B & C IS NOT FOR USE IN CANADA.**

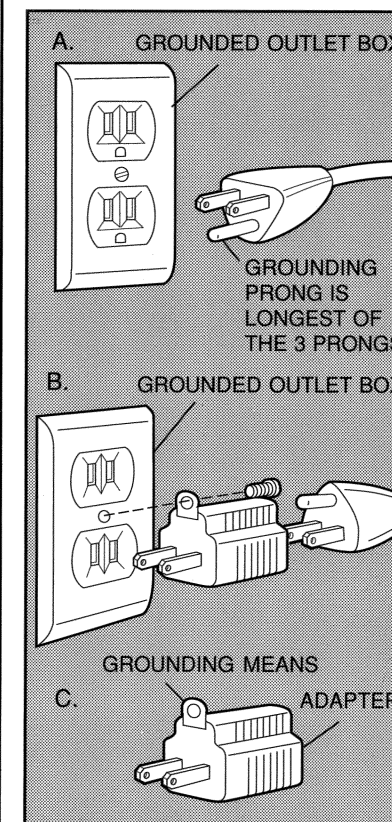

Switch Operation Paddle Switch (Fig. 1)

To start the grinder, depress the paddle by squeezing. To turn the tool off, release the paddle. The switch can be locked on by engaging the lock button, shown in Figure 1, while holding the paddle depressed. Always be sure that the

tool is not locked on before plugging it in. To turn the tool off when it is locked on, squeeze and release the paddle once.

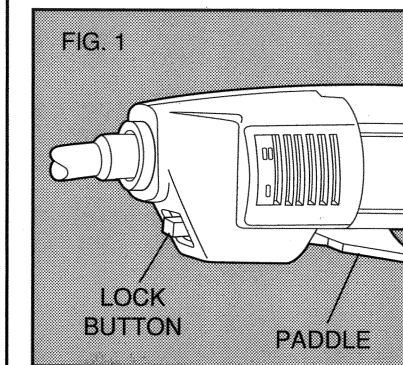

Auxiliary Handle (Fig. 2)

An auxiliary handle is furnished with your grinder and can be screwed into either side or the top of the front housing. This handle **SHOULD BE USED AT ALL TIMES** to maintain complete control of the tool.

Spindle Lock Pin Operation (Fig. 2)

Depress spindle lock pin and rotate the spindle until the spindle lock pin engages to lock the spindle. **NOTE:** Never depress the Spindle Lock Pin when the tool is running or coasting. Damage to the gear and lock pin will result.

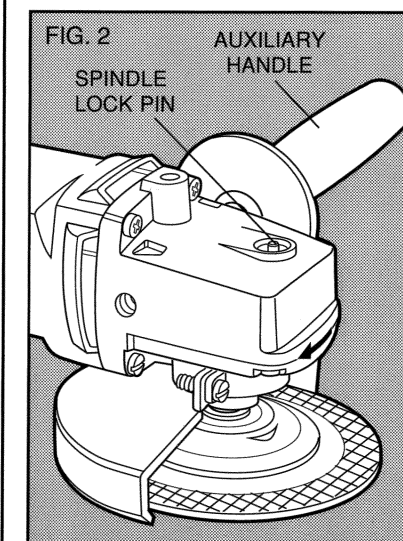

Grinding With Depressed Center Wheels

CAUTION:

Never use Depressed Center Wheels without the proper guard.

Depressed center wheels may be used for moderate metal removal on flat or contoured surfaces.

Installation of Standard Depressed Center Wheels (Non-Hubbed)

1. Be sure tool is disconnected from power supply and switch is in "OFF" position.

STANDARD DEPRESSED CENTER WHEELS (NON-HUBBED)

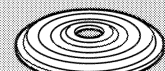
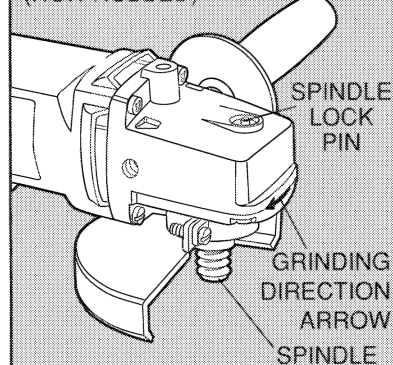

UNIVERSAL TOOL FLANGE



DEPRESSED CENTER GRINDING WHEEL



SPINDLE NUT

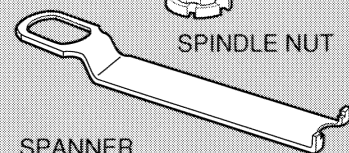

SPANNER WRENCH

FIG. 5

2. Be sure the guard assembly is securely attached to the spindle housing, as shown in Figure 3.
3. Put the Universal Tool Flange onto the tool spindle as shown. See Figure 5.
4. Check MAX. RPM rating on the Depressed Center wheel. Never use wheel with MAX. RPM lower than 12,000 RPM.
5. Install the Depressed Center Wheel on the spindle as shown in Figure 5.
6. Install the spindle nut on the spindle. Depress the spindle lock pin to lock the spindle. Tighten spindle nut with the spanner wrench provided. See Figure 5.

Removal of Standard Depressed Center Wheels

1. Be sure tool is disconnected from power supply and switch is in "OFF" position.
2. Depress the spindle lock pin to lock the spindle.
3. Insert the spanner wrench into the rectangular slots in the spindle nut. Remove the depressed center wheel by turning the spindle nut in the direction of the grinding direction arrow as indicated on tool. See Figure 5.

NOTE: The Wheelfast™ wheel does not use the spindle nut or spanner wrench.

The Universal Tool Flange is required to mount either type of grinding wheel.

NOTE: Never depress the Spindle Lock Pin when the tool is running or coasting. Damage to the gear and lock pin will result.

Grinding Operation

When using any Depressed Center Wheel, hold the tool so that an angle of approximately 30° exists between the wheel and the work.

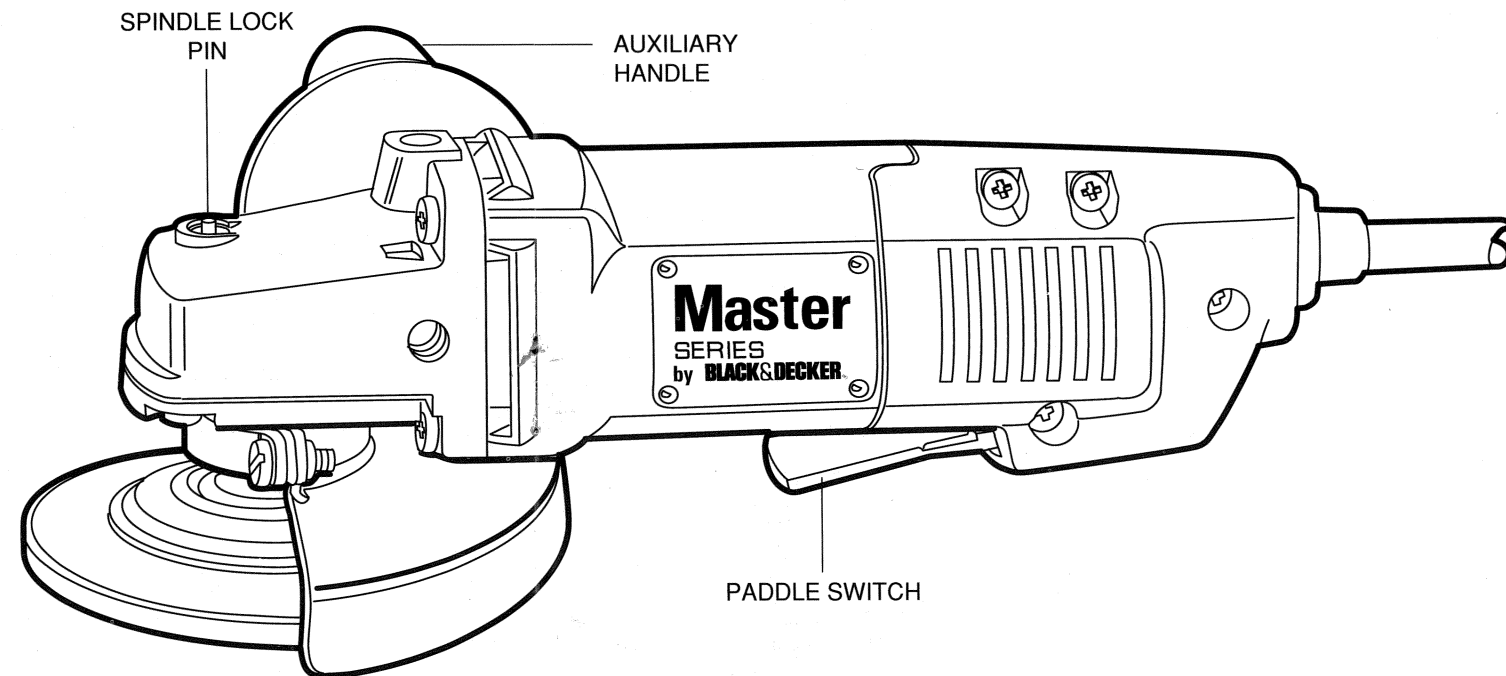

Installation of Wheelfast™ Wheels

1. Be sure tool is disconnected from power supply and switch is in "OFF" position.
2. Be sure the guard assembly is securely attached to the spindle housing, as shown in Figure 3.

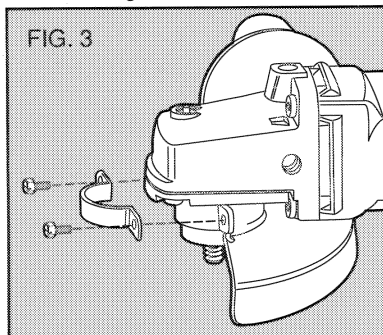

3. Put the Universal Tool Flange onto the tool spindle as shown. NOTE: Once the Universal Tool Flange is installed, it need never be removed. (Exception-When using wire cup & knotted wire wheel brushes and fiber backing discs.)
4. Check MAX. RPM rating on Wheelfast™ wheel. Never use wheel with MAX. RPM lower than 12,000 RPM.
5. Thread the Wheelfast™ Wheel on the tool spindle as shown. Tighten the wheel firmly by hand while depressing the Spindle Lock Pin. See Figure 4.

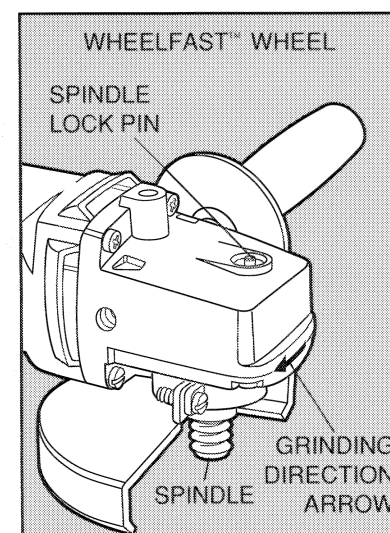

UNIVERSAL TOOL FLANGE

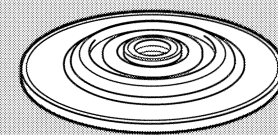

WHEELFAST™ WHEEL

FIG. 4

Removal of Wheelfast™ Wheels

1. Be sure tool is disconnected from power supply and switch is in "OFF" position.
2. Depress the spindle lock pin to lock the spindle.
3. Using a cloth or glove to protect your hand, turn the Wheelfast™ wheel in the direction of the grinding direction arrow as indicated on tool to remove it from the spindle. See Figure 4.

CAUTION:

Tightening wheel by activating motor may necessitate the use of the supplied wrench to remove the wheel. Also, under certain conditions such as very heavy or shock-loading type of grinding, the Wheelfast™ wheel may become too tight for easy hand removal. It may be necessary to remove the wheel with the supplied wrench applied to the flats on the bottom of the Wheelfast™ wheel.

Sanding with Sanding Discs

Using Fiber Backing Disc Sanding Accessory

Black & Decker Accessory Catalog Number 50937 (not included with

unit). Backing Flange and Disc Nut shown in Figure 7 are included in 50937.

Installation of Fiber Backing Disc and Sanding Disc

1. Be sure tool is disconnected from power supply and switch is in "OFF" position.
2. Remove the universal tool flange.
3. Assemble steel backing flange, fiber backing disc, sanding disc, and disc nut to the spindle.
4. Depress the spindle lock pin to lock the spindle. Grasp the sanding disc and the fiber backing disc and turn until the disc nut is tight. See Figure 7.

FIBER BACKING DISC SANDING SYSTEM

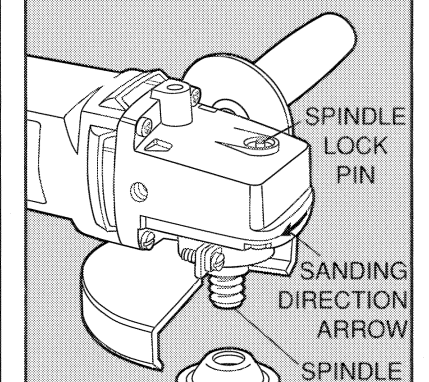

BACKING FLANGE

FIBER BACKING DISC

SANDING DISC



DISC NUT

FIG. 7