

4" Belt / 6" Disc Sander (Model SA446)



PART NO. A05754 - 04-18-05
Copyright © 2005 Delta Machinery



To learn more about DELTA MACHINERY
visit our website at: www.deltamachinery.com.

For Parts, Service, Warranty or other Assistance,

please call **1-800-223-7278** (In Canada call **1-800-463-3582**).

ESPAÑOL: PÁGINA 23

TABLE OF CONTENTS

IMPORTANT SAFETY INSTRUCTIONS2
SAFETY GUIDELINES3
GENERAL SAFETY RULES4
ADDITIONAL SPECIFIC SAFETY RULES5
FUNCTIONAL DESCRIPTION7
CARTON CONTENTS8
ASSEMBLY9
OPERATION13
TROUBLESHOOTING20
MAINTENANCE21
SERVICE21
ACCESSORIES21
WARRANTY22
ESPAÑOL23
SERVICE CENTER LOCATIONSback cover

IMPORTANT SAFETY INSTRUCTIONS

▲ WARNING Read and understand all warnings and operating instructions before using any tool or equipment. When using tools or equipment, basic safety precautions should always be followed to reduce the risk of personal injury. Improper operation, maintenance or modification of tools or equipment could result in serious injury and property damage. There are certain applications for which tools and equipment are designed. Delta Machinery strongly recommends that this product NOT be modified and/or used for any application other than for which it was designed.

If you have any questions relative to its application DO NOT use the product until you have written Delta Machinery and we have advised you.

Online contact form at www.deltamachinery.com

Postal Mail: Technical Service Manager
Delta Machinery
4825 Highway 45 North
Jackson, TN 38305

(IN CANADA: 505 SOUTHGATE DRIVE, GUELPH, ONTARIO N1H 6M7)

Information regarding the safe and proper operation of this tool is available from the following sources:

Power Tool Institute
1300 Sumner Avenue, Cleveland, OH 44115-2851
www.powertoolinstitute.org

National Safety Council
1121 Spring Lake Drive, Itasca, IL 60143-3201

American National Standards Institute, 25 West 43rd Street, 4 floor, New York, NY 10036 www.ansi.org
ANSI 01.1 Safety Requirements for Woodworking Machines, and

the U.S. Department of Labor regulations www.osha.gov

SAVE THESE INSTRUCTIONS!

SAFETY GUIDELINES - DEFINITIONS

It is important for you to read and understand this manual. The information it contains relates to protecting YOUR SAFETY and PREVENTING PROBLEMS. The symbols below are used to help you recognize this information.



- ▲ DANGER** Indicates an imminently hazardous situation which, if not avoided, will result in death or serious injury.
- ▲ WARNING** Indicates a potentially hazardous situation which, if not avoided, could result in death or serious injury.
- ▲ CAUTION** Indicates a potentially hazardous situation which, if not avoided, may result in minor or moderate injury.
- CAUTION** Used without the safety alert symbol indicates potentially hazardous situation which, if not avoided, may result in property damage.

CALIFORNIA PROPOSITION 65

▲ WARNING **SOME DUST CREATED BY POWER SANDING, SAWING, GRINDING, DRILLING, AND OTHER CONSTRUCTION ACTIVITIES** contains chemicals known to cause cancer, birth defects or other reproductive harm.

Some examples of these chemicals are:

- lead from lead-based paints,
- crystalline silica from bricks and cement and other masonry products, and
- arsenic and chromium from chemically-treated lumber.

Your risk from these exposures varies, depending on how often you do this type of work. To reduce your exposure to these chemicals: work in a well ventilated area, and work with approved safety equipment, always wear **NIOSH/OSHA** approved, properly fitting face mask or respirator when using such tools.

GENERAL SAFETY RULES



⚠ WARNING READ AND UNDERSTAND ALL WARNINGS AND OPERATING INSTRUCTIONS BEFORE USING THIS EQUIPMENT. Failure to follow all instructions listed below, may result in electric shock, fire, and/or serious personal injury or property damage.

IMPORTANT SAFETY INSTRUCTIONS

- FOR YOUR OWN SAFETY, READ THE INSTRUCTION MANUAL BEFORE OPERATING THE MACHINE.** Learning the machine's application, limitations, and specific hazards will greatly minimize the possibility of accidents and injury.
- WEAR EYE AND HEARING PROTECTION. ALWAYS USE SAFETY GLASSES.** Everyday eyeglasses are NOT safety glasses. USE CERTIFIED SAFETY EQUIPMENT. Eye protection equipment should comply with ANSI Z87.1 standards. Hearing equipment should comply with ANSI S3.19 standards.
- WEAR PROPER APPAREL.** Do not wear loose clothing, gloves, neckties, rings, bracelets, or other jewelry which may get caught in moving parts. Nonslip footwear is recommended. Wear protective hair covering to contain long hair.
- DO NOT USE THE MACHINE IN A DANGEROUS ENVIRONMENT.** The use of power tools in damp or wet locations or in rain can cause shock or electrocution. Keep your work area well-lit to prevent tripping or placing arms, hands, and fingers in danger.
- MAINTAIN ALL TOOLS AND MACHINES IN PEAK CONDITION.** Keep tools sharp and clean for best and safest performance. Follow instructions for lubricating and changing accessories. Poorly maintained tools and machines can further damage the tool or machine and/or cause injury.
- CHECK FOR DAMAGED PARTS.** Before using the machine, check for any damaged parts. Check for alignment of moving parts, binding of moving parts, breakage of parts, and any other conditions that may affect its operation. A guard or any other part that is damaged **should be properly repaired or replaced.** Damaged parts can cause further damage to the machine and/or injury.
- KEEP THE WORK AREA CLEAN.** Cluttered areas and benches invite accidents.
- KEEP CHILDREN AND VISITORS AWAY.** Your shop is a potentially dangerous environment. Children and visitors can be injured.
- REDUCE THE RISK OF UNINTENTIONAL STARTING.** Make sure that the switch is in the "OFF" position before plugging in the power cord. In the event of a power failure, move the switch to the "OFF" position. An accidental start-up can cause injury.
- USE THE GUARDS.** Check to see that all guards are in place, secured, and working correctly to reduce the risk of injury.
- REMOVE ADJUSTING KEYS AND WRENCHES BEFORE STARTING THE MACHINE.** Tools, scrap pieces, and other debris can be thrown at high speed, causing injury.
- USE THE RIGHT MACHINE.** Don't force a machine or an attachment to do a job for which it was not designed. Damage to the machine and/or injury may result.
- USE RECOMMENDED ACCESSORIES.** The use of accessories and attachments not recommended by Delta may cause damage to the machine or injury to the user.
- USE THE PROPER EXTENSION CORD.** Make sure your extension cord is in good condition. When using an extension cord, be sure to use one heavy enough to carry the current your product will draw. An undersized cord will cause a drop in line voltage, resulting in loss of power and overheating. See the Extension Cord Chart for the correct size depending on the cord length and nameplate ampere rating. If in doubt, use the next heavier gauge. The smaller the gauge number, the heavier the cord.
- SECURE THE WORKPIECE.** Use clamps or a vise to hold the workpiece when practical. Loss of control of a workpiece can cause injury.
- FEED THE WORKPIECE AGAINST THE DIRECTION OF THE ROTATION OF THE BLADE, CUTTER, OR ABRASIVE SURFACE.** Feeding it from the other direction will cause the workpiece to be thrown out at high speed.
- DON'T FORCE THE WORKPIECE ON THE MACHINE.** Damage to the machine and/or injury may result.
- DON'T OVERREACH.** Loss of balance can make you fall into a working machine, causing injury.
- NEVER STAND ON THE MACHINE.** Injury could occur if the tool tips, or if you accidentally contact the cutting tool.
- NEVER LEAVE THE MACHINE RUNNING UNATTENDED. TURN THE POWER OFF.** Don't leave the machine until it comes to a complete stop. A child or visitor could be injured.
- TURN THE MACHINE "OFF", AND DISCONNECT THE MACHINE FROM THE POWER SOURCE** before installing or removing accessories, before adjusting or changing set-ups, or when making repairs. An accidental start-up can cause injury.
- MAKE YOUR WORKSHOP CHILDPROOF WITH PADLOCKS, MASTER SWITCHES, OR BY REMOVING STARTER KEYS.** The accidental start-up of a machine by a child or visitor could cause injury.
- STAY ALERT, WATCH WHAT YOU ARE DOING, AND USE COMMON SENSE. DO NOT USE THE MACHINE WHEN YOU ARE TIRED OR UNDER THE INFLUENCE OF DRUGS, ALCOHOL, OR MEDICATION.** A moment of inattention while operating power tools may result in injury.
- ⚠ WARNING** USE OF THIS TOOL CAN GENERATE AND DISBURSE DUST OR OTHER AIRBORNE PARTICLES, INCLUDING WOOD DUST, CRYSTALLINE SILICA DUST AND ASBESTOS DUST. Direct particles away from face and body. Always operate tool in well ventilated area and provide for proper dust removal. Use dust collection system wherever possible. Exposure to the dust may cause serious and permanent respiratory or other injury, including silicosis (a serious lung disease), cancer, and death. Avoid breathing the dust, and avoid prolonged contact with dust. Allowing dust to get into your mouth or eyes, or lay on your skin may promote absorption of harmful material. Always use properly fitting NIOSH/OSHA approved respiratory protection appropriate for the dust exposure, and wash exposed areas with soap and water.

ADDITIONAL SPECIFIC SAFETY RULES

⚠ WARNING

FAILURE TO FOLLOW THESE RULES MAY RESULT IN SERIOUS INJURY.

1. **DO NOT OPERATE THIS MACHINE** until it is completely assembled and installed according to the instructions. A machine incorrectly assembled can cause serious injury.
2. **OBTAIN ADVICE** from your supervisor, instructor, or another qualified person if you are not thoroughly familiar with the operation of this machine. Knowledge is safety.
3. **FOLLOW ALL WIRING CODES** and recommended electrical connections to prevent shock or electrocution.
4. **NEVER TURN THE MACHINE "ON"** before clearing the table/work area of all objects (tools, scraps of wood, etc.). Flying debris is dangerous.
5. **NEVER TURN THE MACHINE "ON"** with the workpiece contacting the abrasive surface. Kickback can occur.
6. **SECURE THE MACHINE** to a supporting surface. Vibration can cause the machine to slide, walk, or tip over.
7. **COVER THE POWER TAKE-OFF SHAFT** when not using accessories. Unguarded rotating shafts can create an entanglement hazard which can result in injury.
8. **USE A DUST COLLECTION SYSTEM.** Some types of wood are known to cause disease or other health problems.
9. **CLEAN THE MACHINE** and dust collector thoroughly when processing different types of workpieces (wood, steel, or aluminum). Combining wood and metal dust can create an explosion or fire hazard. **DO NOT SAND OR POLISH MAGNESIUM.** Fire will result.
10. **PREVENT THE WORKPIECE** from contacting the sanding belt before starting the tool. Loss of control of the workpiece is dangerous.
11. **AVOID AWKWARD OPERATIONS AND HAND POSITIONS.** A sudden slip could cause a hand to move into the abrasive disc or belt.
12. **MAINTAIN A MAXIMUM CLEARANCE OF 1/16"** between the table and the abrasive disc or belt. The workpiece could be drawn into the space between the abrasive disc or belt and the table.
13. **SUPPORT THE WORKPIECE** firmly with a miter gauge, backstop, or work table when sanding with a belt. Hold the workpiece firmly. Loss of control of the workpiece can result in injury.
14. **AVOID KICKBACK** by sanding in accordance with the directional arrows. Feed the workpiece against the downward rotation side of the disc or the forward rotation of the belt. Loss of control of the workpiece can result in injury.
15. **DO NOT SAND** very small or very thin workpieces that cannot be safely controlled. Loss of control of the workpiece can result in injury.
16. **PROPERLY SUPPORT LONG OR WIDE WORKPIECES.** Loss of control of the workpiece is dangerous.
17. **NEVER PERFORM LAYOUT, ASSEMBLY, OR SET-UP WORK** on the table/work area when the machine is running. A sudden slip could cause a hand to move into the abrasive surface. Severe injury can result.
18. **TURN THE MACHINE "OFF"**, disconnect the machine from the power source, and clean the table/work area before leaving the machine. **LOCK THE SWITCH IN THE "OFF" POSITION** to prevent unauthorized use. Someone else might accidentally start the machine and cause injury to themselves.
19. **ADDITIONAL INFORMATION** regarding the safe and proper operation of power tools (i.e. a safety video) is available from the Power Tool Institute, 1300 Sumner Avenue, Cleveland, OH 44115-2851 (www.powertoolinstitute.com). Information is also available from the National Safety Council, 1121 Spring Lake Drive, Itasca, IL 60143-3201. Please refer to the American National Standards Institute ANSI 01.1 Safety Requirements for Woodworking Machines and the U.S. Department of Labor OSHA 1910.213 Regulations.

SAVE THESE INSTRUCTIONS.
Refer to them often
and use them to instruct others.

POWER CONNECTIONS

A separate electrical circuit should be used for your machines. This circuit should not be less than #12 wire and should be protected with a 20 Amp time lag fuse. If an extension cord is used, use only 3-wire extension cords which have 3-prong grounding type plugs and matching receptacle which will accept the machine's plug. Before connecting the machine to the power line, make sure the switch (s) is in the "OFF" position and be sure that the electric current is of the same characteristics as indicated on the machine. All line connections should make good contact. Running on low voltage will damage the machine.

⚠ DANGER DO NOT EXPOSE THE MACHINE TO RAIN OR OPERATE THE MACHINE IN DAMP LOCATIONS.

MOTOR SPECIFICATIONS

Your machine is wired for 120 Volt, 60 HZ alternating current. Before connecting the machine to the power source, make sure the switch is in the "OFF" position.

GROUNDING INSTRUCTIONS

⚠ DANGER THIS MACHINE MUST BE GROUNDED WHILE IN USE TO PROTECT THE OPERATOR FROM ELECTRIC SHOCK.

1. All grounded, cord-connected machines:

In the event of a malfunction or breakdown, grounding provides a path of least resistance for electric current to reduce the risk of electric shock. This machine is equipped with an electric cord having an equipment-grounding conductor and a grounding plug. The plug must be plugged into a matching outlet that is properly installed and grounded in accordance with all local codes and ordinances.

Do not modify the plug provided - if it will not fit the outlet, have the proper outlet installed by a qualified electrician.

Improper connection of the equipment-grounding conductor can result in risk of electric shock. The conductor with insulation having an outer surface that is green with or without yellow stripes is the equipment-grounding conductor. If repair or replacement of the electric cord or plug is necessary, do not connect the equipment-grounding conductor to a live terminal.

Check with a qualified electrician or service personnel if the grounding instructions are not completely understood, or if in doubt as to whether the machine is properly grounded.

Use only 3-wire extension cords that have 3-prong grounding type plugs and matching 3-conductor receptacles that accept the machine's plug, as shown in Fig. A.

Repair or replace damaged or worn cord immediately.

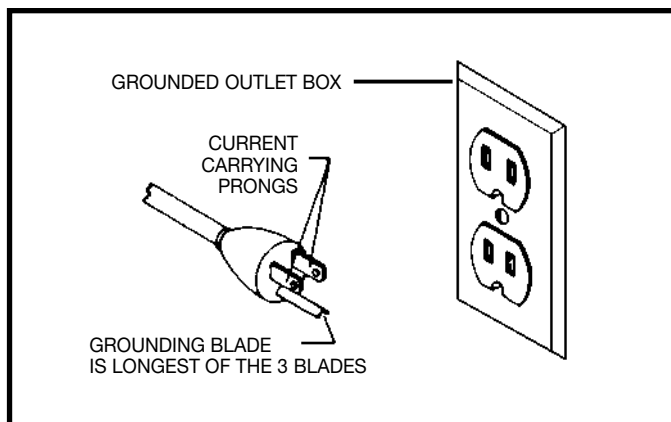

Fig. A

2. Grounded, cord-connected machines intended for use on a supply circuit having a nominal rating less than 150 volts:

If the machine is intended for use on a circuit that has an outlet that looks like the one illustrated in Fig. A, the machine will have a grounding plug that looks like the plug illustrated in Fig. A. A temporary adapter, which looks like the adapter illustrated in Fig. B, may be used to connect this plug to a matching 2-conductor receptacle as shown in Fig. B if a properly grounded outlet is not available. The temporary adapter should be used only until a properly grounded outlet can be installed by a qualified electrician. The green-colored rigid ear, lug, and the like, extending from the adapter must be connected to a permanent ground such as a properly grounded outlet box. Whenever the adapter is used, it must be held in place with a metal screw.

NOTE: In Canada, the use of a temporary adapter is not permitted by the Canadian Electric Code.

⚠ DANGER IN ALL CASES, MAKE CERTAIN THAT THE RECEPTACLE IN QUESTION IS PROPERLY GROUNDED. IF YOU ARE NOT SURE, HAVE A QUALIFIED ELECTRICIAN CHECK THE RECEPTACLE.

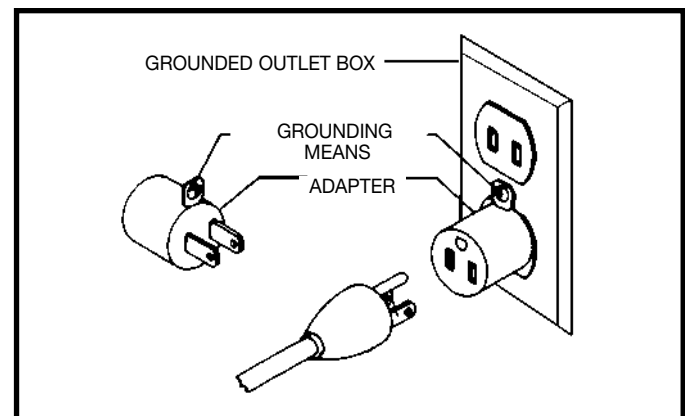

Fig. B

EXTENSION CORDS

⚠ WARNING Use proper extension cords. Make sure your extension cord is in good condition and is a 3-wire extension cord which has a 3-prong grounding type plug and matching receptacle which will accept the machine's plug. When using an extension cord, be sure to use one heavy enough to carry the current of the machine. An undersized cord will cause a drop in line voltage, resulting in loss of power and overheating. Fig. D-1 shows the correct gauge to use depending on the cord length. If in doubt, use the next heavier gauge. The smaller the gauge number, the heavier the cord.

MINIMUM GAUGE EXTENSION CORD			
RECOMMENDED SIZES FOR USE WITH STATIONARY ELECTRIC MACHINES			
Ampere Rating	Volts	Total Length of Cord in Feet	Gauge of Extension Cord
0-6	120	up to 25	18 AWG
0-6	120	25-50	16 AWG
0-6	120	50-100	16 AWG
0-6	120	100-150	14 AWG
6-10	120	up to 25	18 AWG
6-10	120	25-50	16 AWG
6-10	120	50-100	14 AWG
6-10	120	100-150	12 AWG
10-12	120	up to 25	16 AWG
10-12	120	25-50	16 AWG
10-12	120	50-100	14 AWG
10-12	120	100-150	12 AWG
12-16	120	up to 25	14 AWG
12-16	120	25-50	12 AWG
12-16	120	GREATER THAN 50 FEET NOT RECOMMENDED	

Fig. D-1

FUNCTIONAL DESCRIPTION

FOREWORD

The Delta ShopMaster Model SA446 is a 4" Belt, 6" Disc Sander that comes equipped with a 1/3 hp 120 Volt Single Phase Induction Motor, a tilting table, a miter gauge, a backstop, a 4" x 36" 60-grit sanding belt, and a 6" 60-grit sanding disc. You can mount the tilting table for use on either the belt or disc unit, and can operate the belt in the horizontal position, the vertical position, or any position in between.

NOTICE: The photo on the manual cover illustrates the current production model. All other illustrations contained in the manual are representative only and may not depict the actual color, labeling, or accessories, and are intended to illustrate technique only.

CARTON CONTENTS

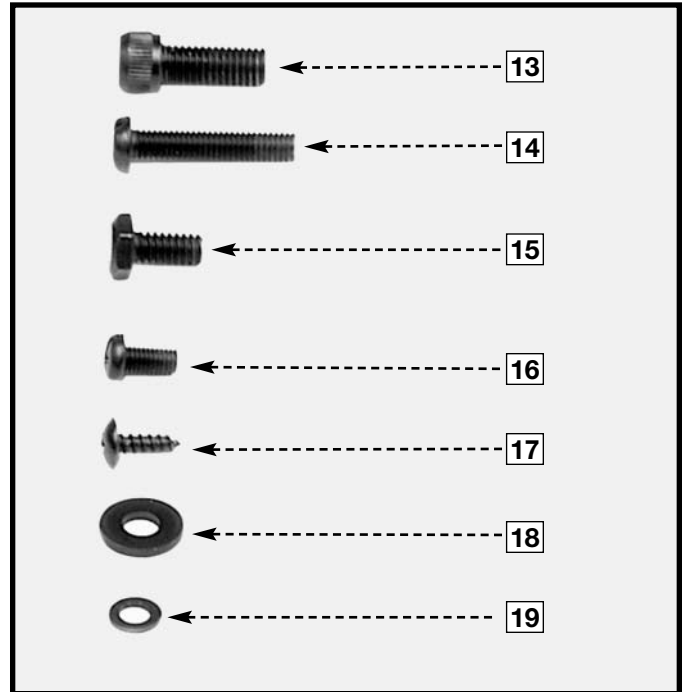
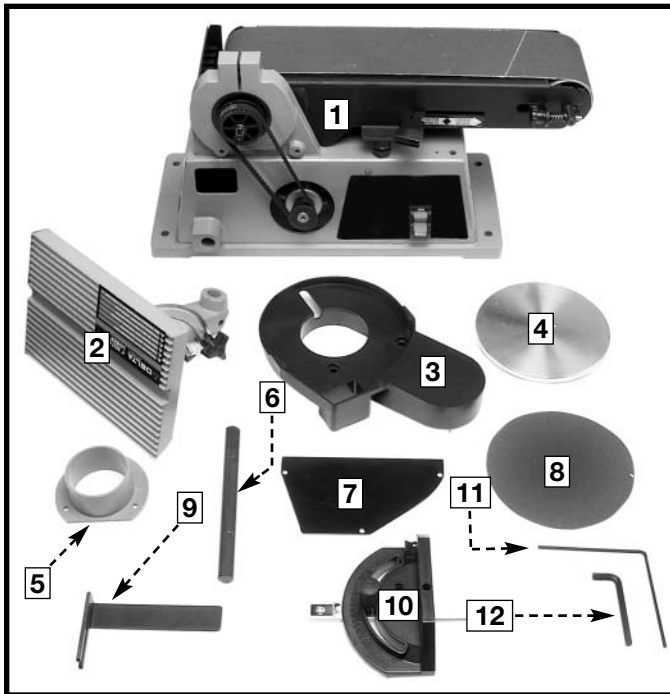

1. Motor and Base
2. Disc Table
3. Belt and Pulley Guard
4. Disc Plate
5. Dust Chute
6. Support Rod
7. Lower Disc Guard
8. Sanding Disc
9. Backstop
10. Miter Gauge

11. 1/8" Hex Wrench
12. 6mm Hex Wrench
13. M8 x 1.25 x 20mm Hex Socket Head Screw (3)
14. M6 x 1 x 30mm Cheese Head Screws (2)
15. 1/4-20 x 1/2" Hex Head Screw (1)
16. M5 x .08 x 10mm Pan Head Screw (3)
17. M4 x .7 x 12mm Sheet Metal Screw (3)
18. 5/16" Flat Washer (1)
19. M5.3 Flat Washer (3)

UNPACKING AND CLEANING

Carefully unpack the machine and all loose items from the shipping container(s). Remove the protective coating from all unpainted surfaces. This coating may be removed with a soft cloth moistened with kerosene (do not use acetone, gasoline or lacquer thinner for this purpose). After cleaning, cover the unpainted surfaces with a good quality household floor paste wax.

ASSEMBLY

⚠ WARNING For your own safety, do not connect the machine to the power source until the machine is completely assembled and you read and understand the entire instruction manual.

ASSEMBLY TOOLS REQUIRED

1/8" Hex Wrench (Supplied)

Phillips Screwdriver

6 Mm Hex Wrench (Supplied)

Adjustable Wrench

ASSEMBLY TIME ESTIMATE

Less than one hour

ADJUSTING THE BELT TENSION

Your sander was shipped from the factory with the drive belt (A) Fig. 1 attached to both pulleys (B) and (C). Before assembling the machine, check and adjust the belt tension.

1. Loosen the screw (D) Fig. 1 with the 6mm hex wrench, and move the sanding arm (E) to the vertical position to expose belt tensing screw (F) Fig. 2, and locknut (G).

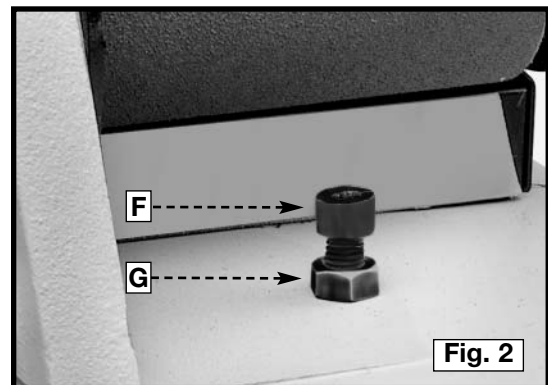
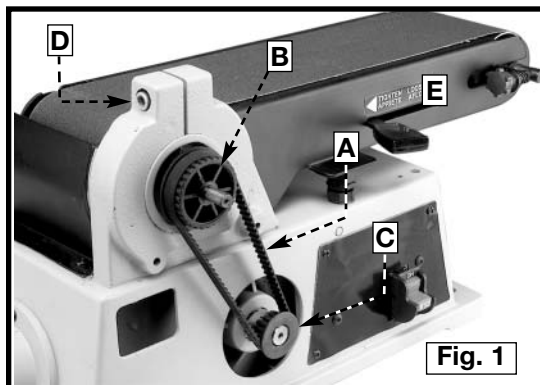

2. Check the belt tension by applying light pressure on the belt halfway between the two pulleys. The belt has the correct tension when you can deflect it approximately 1/4".

NOTE: The belt does not require excessive tension to function properly.

3. To adjust, loosen the locknut (A) Fig. 3, and tighten or loosen the adjusting screw (B) with the supplied 6mm hex wrench until the belt has the correct tension.
4. Tighten locknut (A).
5. Move the sanding arm to the horizontal position.

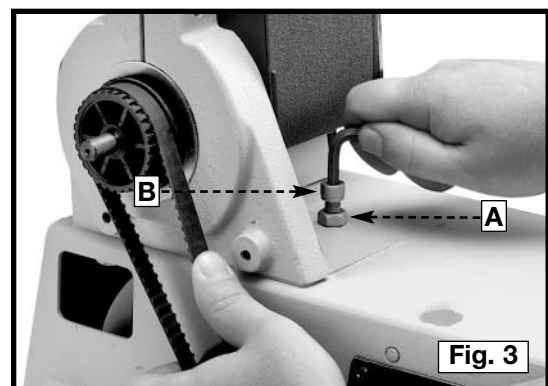

ATTACHING THE BELT AND PULLEY GUARD

Attach the belt and pulley guard (A) Fig. 4 to the machine base using the two M6x1x30mm cheese head screws (B).

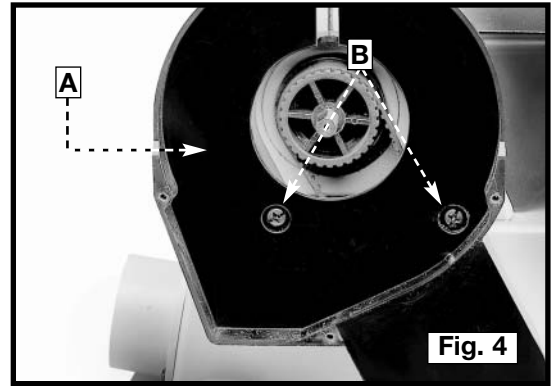

INSTALLING THE SANDING DISC PLATE

1. Turn the 1/4-20 x 1/4" hex socket set screw (A) Fig. 5 counter-clockwise until it clears the hole (B) Fig. 5 in the sanding plate.

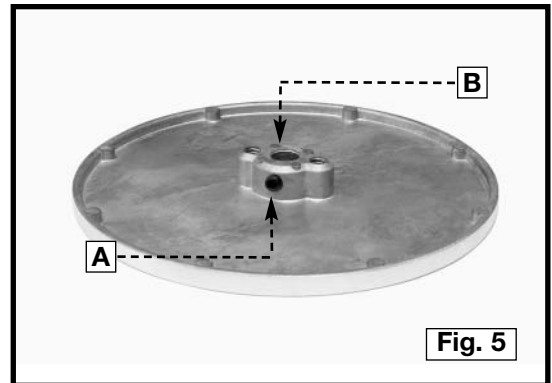

2. Align the flat of the drive shaft with the set screw (A) Fig. 6 in the hub of the plate (B) and install the sanding disc plate (B) on the drive shaft. Slide the plate (B) on the shaft (C) until the plate surface and the shaft are flush.

Note: Do not allow the shaft to extend past the surface of the plate.

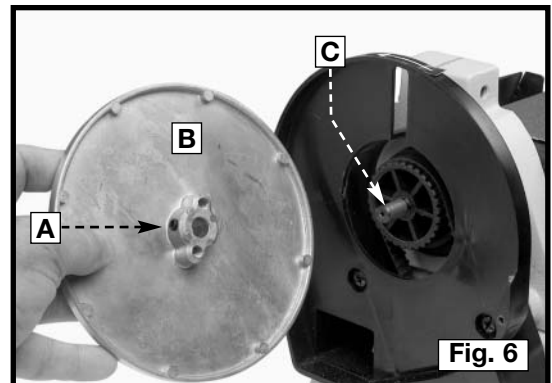

3. Use the supplied 1/8" hex wrench (A) Fig. 7 to tighten the set screw, located in the slot in the back of belt and pulley guard.

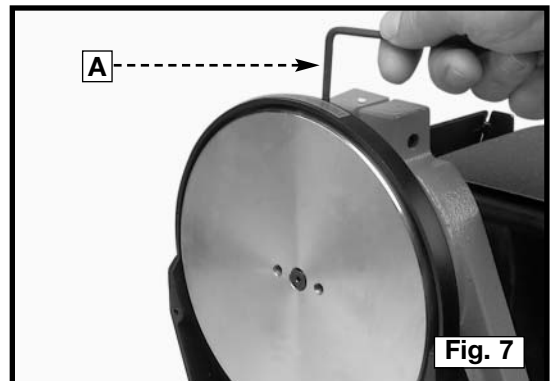

ATTACHING THE SANDING DISC

1. Clean the sanding disc plate (A) Fig. 8.
2. Peel the backing from sanding disc and press the disc (B) firmly into position all the way around the sanding plate (Fig. 8).

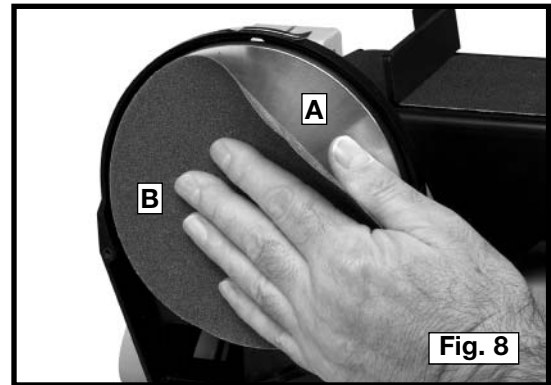

ATTACHING THE LOWER COVER FOR THE SANDING DISC

Install the lower cover (A) Fig. 9 on the belt and pulley guard, using the three M4 x .7 x 12mm sheet metal screws (B).

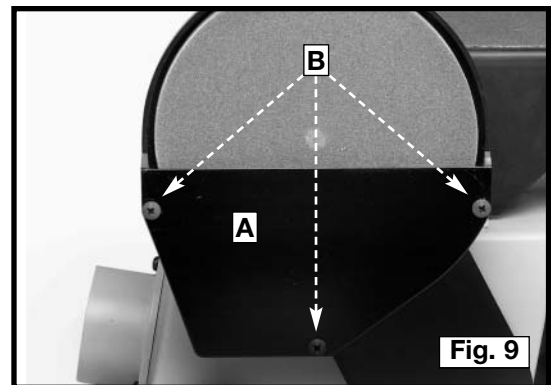

INSTALLING THE DISC SANDER TABLE

1. Thread an M8 x 1.25 x 20mm hex socket head screw (A) Fig. 10 partially into the hole in the base of the sander. Insert the rod (B) into the hole. Align the flat of the rod (B) with the screw (A). Tighten the screw (A).
2. Slide the table assembly (C) Fig. 11 on the rod (B).
3. Thread an M8 x 1.25 x 20mm hex socket head screw (D) Fig. 11 into the hole in the table support bracket. Align the flat on the rod (B) with the screw (A). Tighten the screw (A).

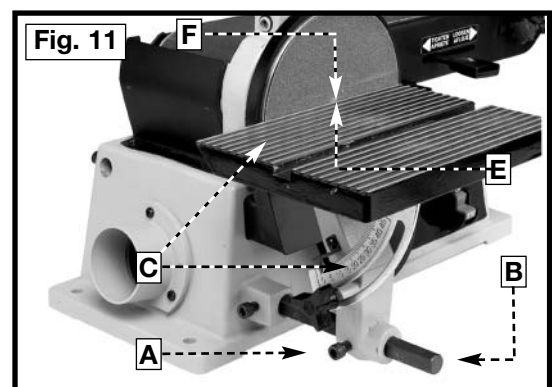
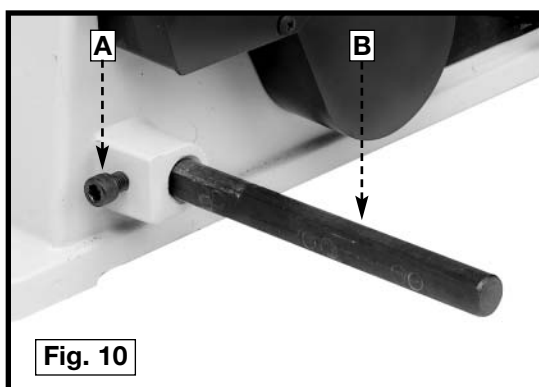

⚠ WARNING To avoid trapping the work or fingers between the table and the sanding disc, the table edge (E) Fig. 11 should be positioned a maximum of 1/16" away from the sanding disc (F). Loosen the screw (D) and adjust the table accordingly.

ATTACHING THE DUST CHUTE

Align the three holes in the dust chute (A) Fig. 12 with the three holes in the left side of the sanding base. Place an M5.3 flat washer on an M5 x .08 x 10mm pan head screw (B) Fig. 12. Insert the screw through the hole in the dust spout and thread it into the tapped hole in the sander base. Repeat this process for the two remaining holes.

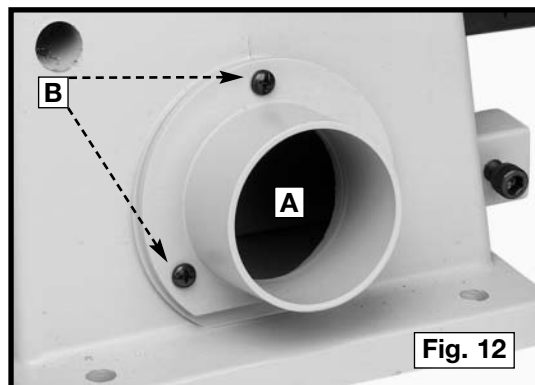

INSTALLING THE BACKSTOP ON THE SANDING ARM

Install the backstop (A) Fig. 13 on the sanding arm using the 1/4-20 x 1/2" hex head screw (B) and 5/16" flat washer (C).

⚠ WARNING To avoid trapping the work or fingers between the backstop and the sanding belt, the edge of the backstop (D) Fig. 13 should be positioned a maximum of 1/16" away from the sanding belt (E).

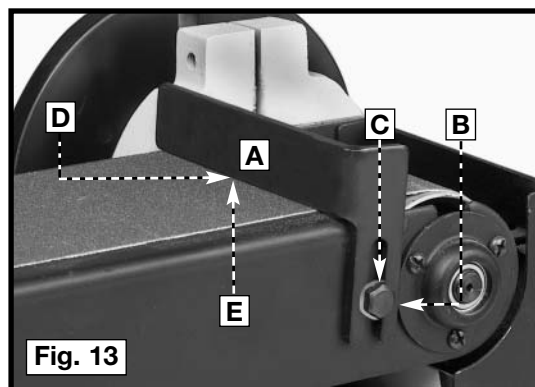

FASTENING THE SANDER TO A SUPPORTING SURFACE

1. To use your sander in a permanent location, fasten it securely to a firm supporting surface, such as a stand or workbench. Use the four holes, three of which are shown at (A) Fig. 14.

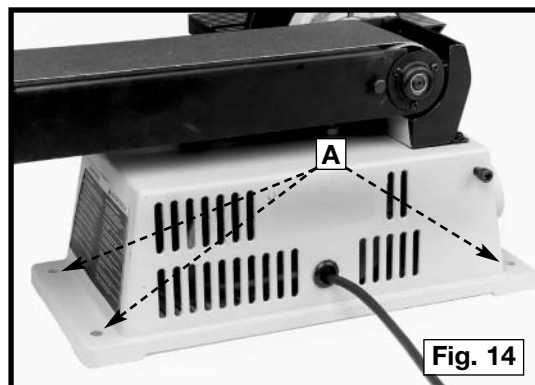

2. The diagram in Fig. 15 illustrates the size and center-to-center distance of the holes to be drilled in the stand or workbench.

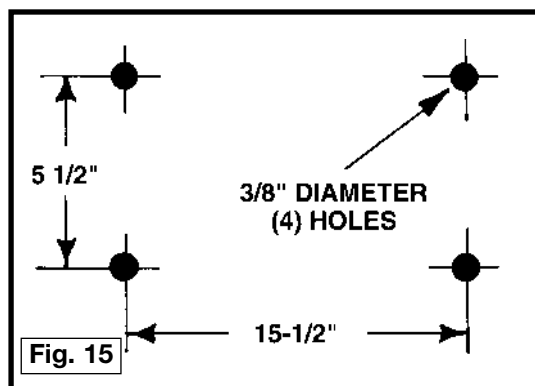

3. Alternately, you can secure the sander by fastening it to a mounting board 18" x 24" or larger. The diagram in Fig. 16 shows the size and center-to-center distance of the holes that you will need to drill in the mounting board.

NOTE: For proper stability, countersink the holes underneath the mounting board so that the screw heads are flush with bottom surface.

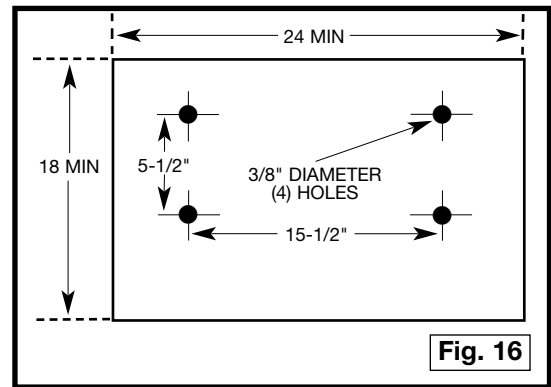

4. Securely clamp the mounting board to a stand or workbench using 2 or more "C" clamps, as shown in Fig. 17.

IMPORTANT: If, during operation, the machine has a tendency to tip over, slide, or walk on the supporting surface, secure the machine base to the supporting surface.



OPERATION

OPERATIONAL CONTROLS AND ADJUSTMENTS

STARTING AND STOPPING THE SANDER

1. The on/off switch (A) Fig. 18 is located on the front of the sander. To turn the machine "ON", move the switch up to the "ON" position.
2. To turn the machine "OFF", move the switch (A) down to the "OFF" position.

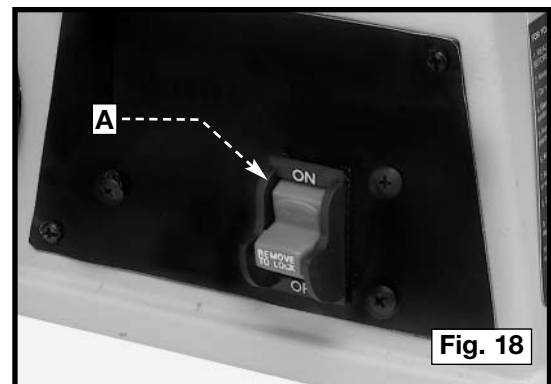

⚠ WARNING

Make sure that the switch is in the "OFF" position before plugging in the power cord. In the event of a power failure, move the switch to the "OFF" position. An accidental start-up can cause injury.

LOCKING THE SWITCH IN THE “OFF” POSITION

IMPORTANT: When the tool is not in use, the switch should be locked in the “OFF” position to prevent unauthorized use. To lock the machine, grasp the switch toggle (A) and pull it out of the switch (Fig. 19). With the switch toggle (A) removed, the switch will not operate. However, should the switch toggle be removed while the saw is running, the machine can be turned “OFF,” but cannot be restarted without re-inserting the switch toggle (A).

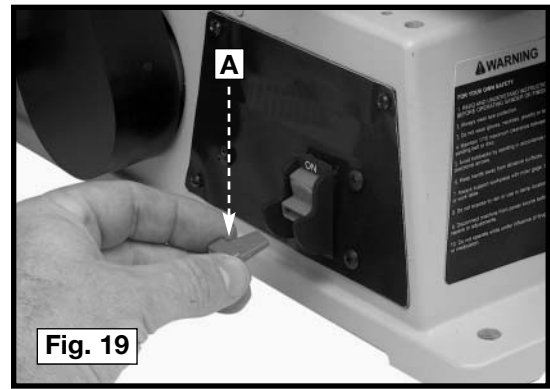

TRACKING THE SANDING BELT

1. Turn the switch “ON” to see if the sanding belt moves to one side or the other on the sanding drums. If the belt rides on the center of the sanding drums, it is tracking properly. Turn the switch “OFF”.
2. If the sanding belt moves toward the disc, turn the tracking knob (A) Fig. 20 counter-clockwise 1/4 turn.
3. If the sanding belt moves away from the disc, turn the tracking knob (A) Fig. 20 clockwise 1/4 turn.
4. Check again to see if the belt is tracking properly.

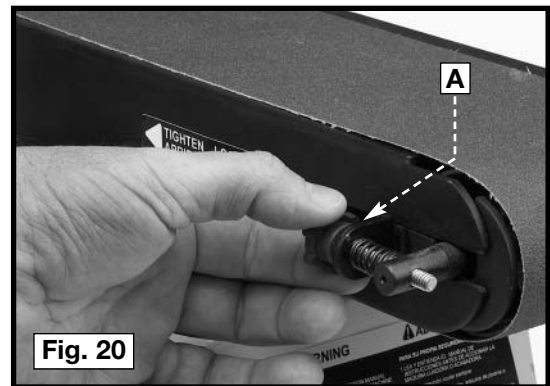

CHANGING THE POSITION OF THE SANDING ARM

⚠ WARNING DISCONNECT MACHINE FROM POWER SOURCE.

You can use the sanding arm (A) in the horizontal position (Fig. 21), the vertical position (Fig. 22), or any angle in between. Loosen the screw (B), position the arm (A) to the desired angle, and tighten the screw (B).

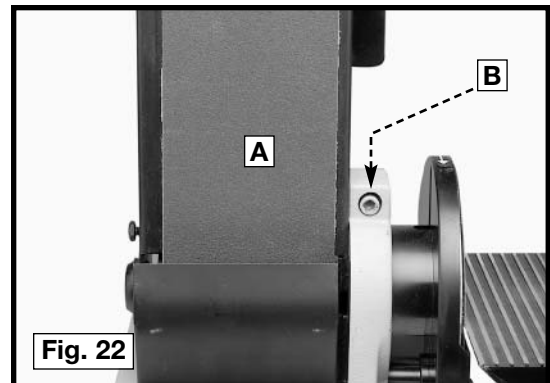
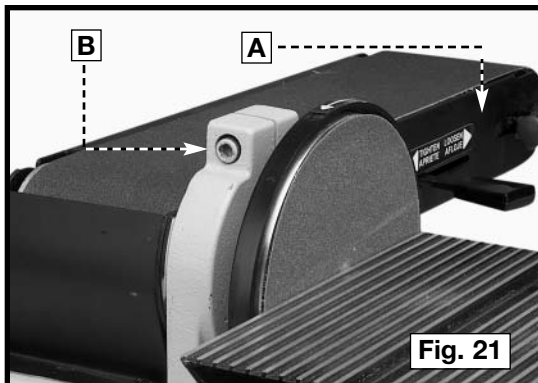

ADJUSTING THE BACKSTOP SQUARE WITH THE SANDING BELT

⚠ WARNING DISCONNECT MACHINE FROM POWER SOURCE.

1. Before adjusting, move the belt tension lever (A) Fig. 23 all the way to the left to the "TIGHTEN" position.
2. Place a square (B) Fig. 24 on the sanding belt with one end of the square against the backstop. See if the backstop is square with the sanding belt.
3. Loosen the screw (C) Fig. 24 and adjust the backstop.

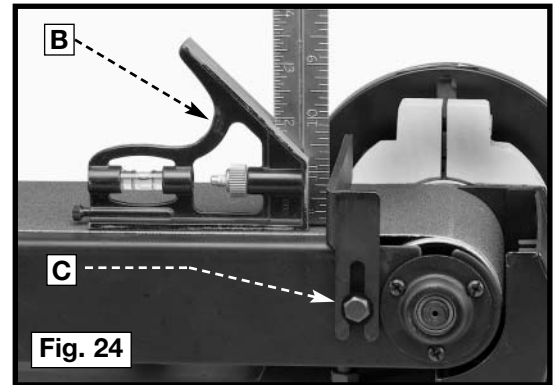
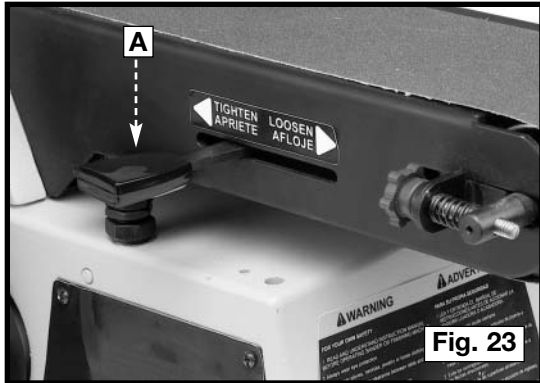

TILTING THE TABLE

⚠ WARNING DISCONNECT MACHINE FROM POWER SOURCE.

You can tilt the table up to 45 degrees to the right by loosening the table lock knob (A) Fig. 25.

⚠ WARNING After tilting, the table must be repositioned on the support rod (B) Fig. 25 to provide a maximum of 1/16" distance between the sanding disc (C) and the edge (D) of the table to avoid trapping the work or fingers between the disc and the table. To reposition the table assembly, loosen the screw (E), move the table assembly on the rod (B) and tighten the screw.

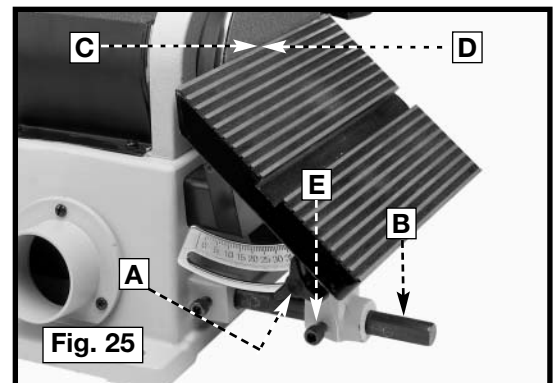

ADJUSTING THE TABLE SQUARE WITH THE SANDING DISC

⚠ WARNING DISCONNECT MACHINE FROM POWER SOURCE.

1. Use a combination square with one end on the table and the other end against the sanding disc (Fig. 26). See if the table is 90 degrees to the disc.
2. To adjust, loosen the table lock knob (A) Fig. 26, move the table square with the disc and tighten the lock knob (A).
3. Adjust the pointer (B) Fig. 26 to the "0" degree mark on the angle scale.

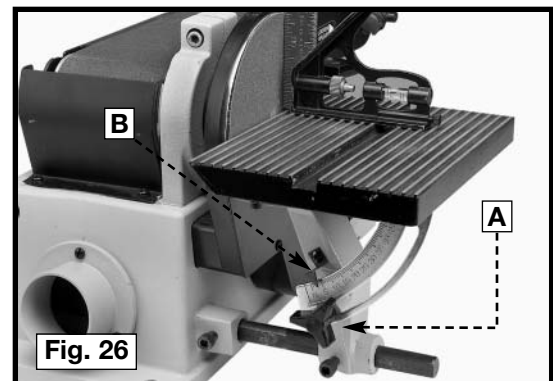

ADJUSTING THE MITER GAUGE SLOT PARALLEL WITH THE SANDING DISC

⚠ WARNING DISCONNECT MACHINE FROM POWER SOURCE.

1. Place an adjustable combination square on the table with the part (A) Fig. 27 in the miter gauge slot (B) to check the distance from the slot to the sanding disc. Check the other side of the disc in the same manner (Fig. 28). The distances should be the same.

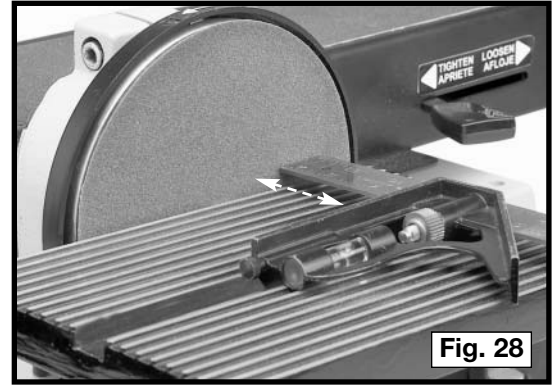
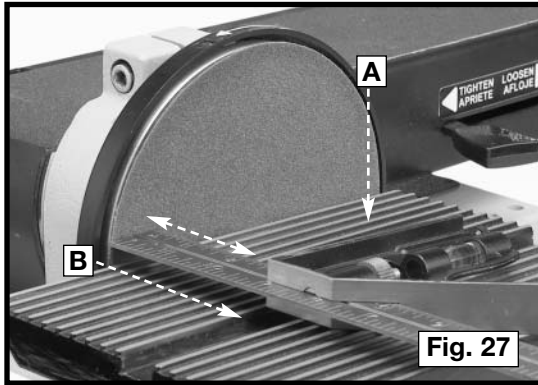

2. To adjust, loosen the three screws (B) Fig. 29 that fasten the table to the table mounting bracket and trunnion. Adjust the table accordingly - then tighten the three screws (B).

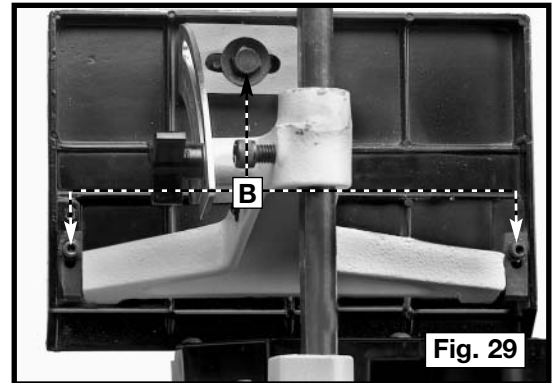

MITER GAUGE

Use the miter gauge (A) Fig. 30 on the disc table. You can rotate the miter gauge body (A) right or left for angle or miter sanding by loosening the lock knob (B), rotating the miter gauge body, and tightening the lock knob (B).

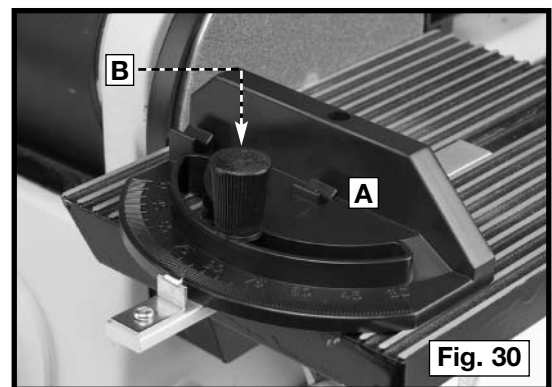

USING THE TABLE ASSEMBLY WITH THE SANDING ARM

When you use the sanding arm (A) Fig. 31 in the vertical position, you can move the complete table assembly (B) from the disc unit to the belt unit.

⚠ WARNING DISCONNECT MACHINE FROM POWER SOURCE.

1. Remove the backstop (C) Fig. 31.
2. Thread the M8 x 1.25 x 20mm hex socket head screw (D) Fig. 31 **ONLY PART OF THE WAY** into the base casting.
3. Loosen the screw (E) Fig. 31, and remove the table assembly (B) from the disc unit. Insert the bar (F) into the hole (G) on the belt unit. Align the flat on the shaft with the screw in the casting and tighten the screw.

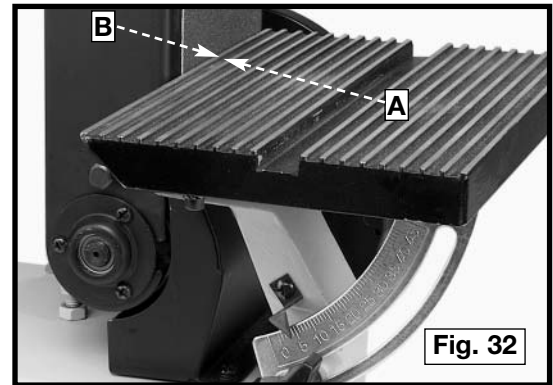
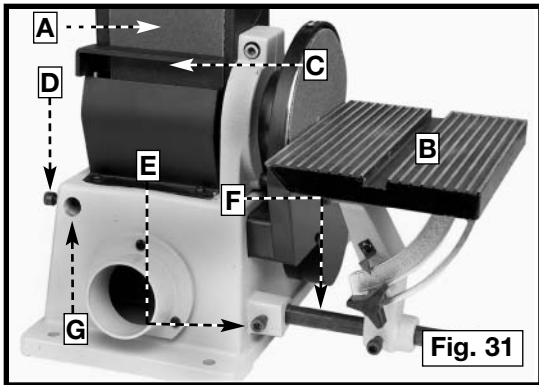

⚠ WARNING To avoid trapping the work or fingers between the backstop and the sanding belt, the edge of the table (A) Fig. 32 should be positioned a maximum of 1/16" away from the sanding belt (B).

WRENCH STORAGE

Two holes are provided in the base casting to store the two wrenches (A) Fig. 33, supplied with the sander.

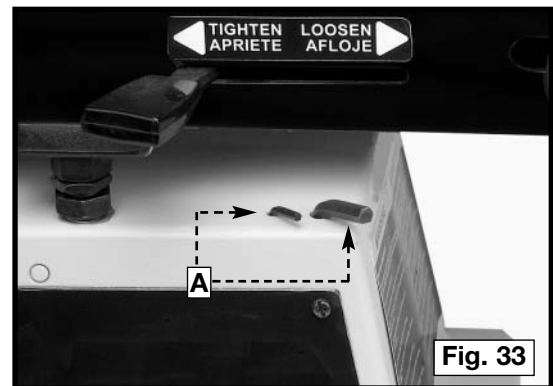

REPLACING THE SANDING BELT

⚠ WARNING DISCONNECT MACHINE FROM POWER SOURCE.

1. Loosen the screw (A) Fig. 34 and remove the backstop (B).
2. Slide the tension lever (C) Fig. 35 to the right to release the tension on the sanding belt. Remove the sanding belt (D) from both sanding drums.
3. An arrow is printed on the back of the sanding belt to indicate the travel direction of the belt. Make certain that this arrow and the arrow on the machine match. Slide the new sanding belt over both sanding drums.
4. Apply belt tension by sliding the tension lever (C) Fig. 35 to the left.
5. Replace the backstop that was removed in **STEP 2**.
6. Connect the power source to the sander. Check the belt tracking. (Refer to the section "**TRACKING THE SANDING BELT**").

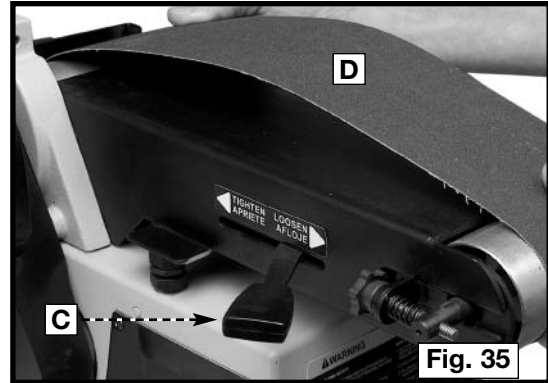
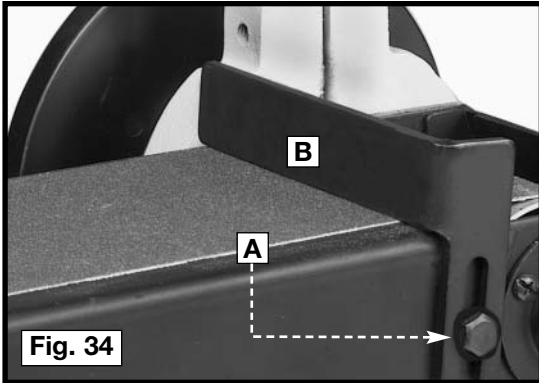

REPLACING THE SANDING DISC

⚠ WARNING DISCONNECT MACHINE FROM POWER SOURCE.

1. Loosen the screw (A) Fig. 36 to remove the table assembly (B).
2. Remove the three screws (B) Fig. 37. Remove the cover (D).
3. Peel off the old disc (E) Fig. 38.
4. Clean the disc plate (F) Fig. 38. Peel the backing from new sanding disc. Press the new sanding disc firmly into position on disc plate (F) and replace the lower cover and table assembly removed in **STEPS 1 and 2**.

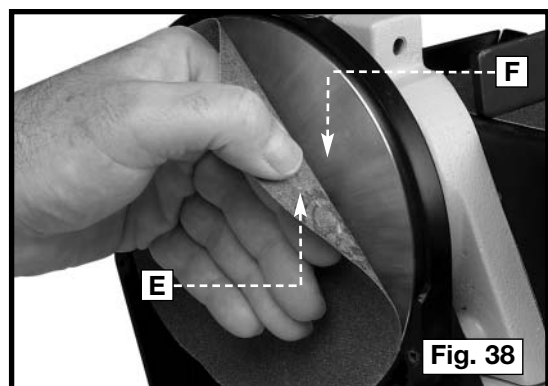
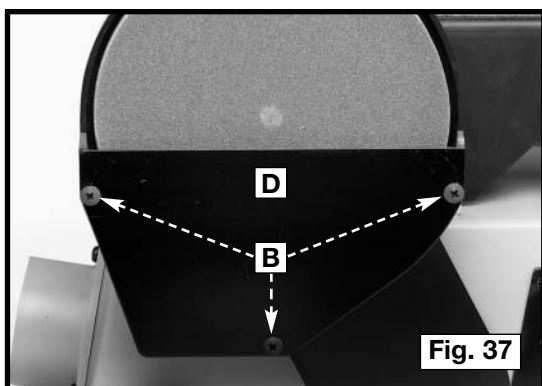
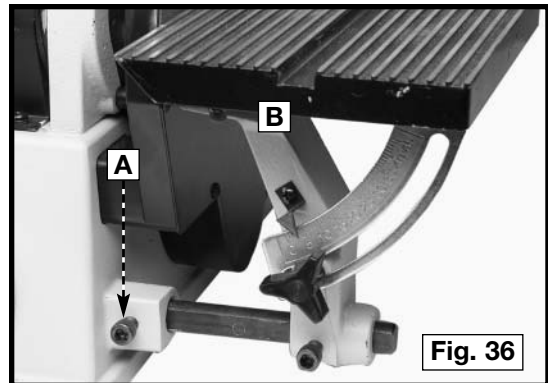

MACHINE USE

SURFACING OR EDGE SANDING WITH THE SANDING BELT

Always use the backstop (A) Figs. 39 and 40 when surface-sanding (Fig. 39) or when edge sanding Fig. 40. Hold the workpiece firmly and keep your fingers away from the sanding belt. Keep the end of the workpiece against the backstop and move the workpiece evenly across the sanding belt. Apply only enough pressure to allow the sanding belt to remove material. Use extra caution when sanding very thin pieces.

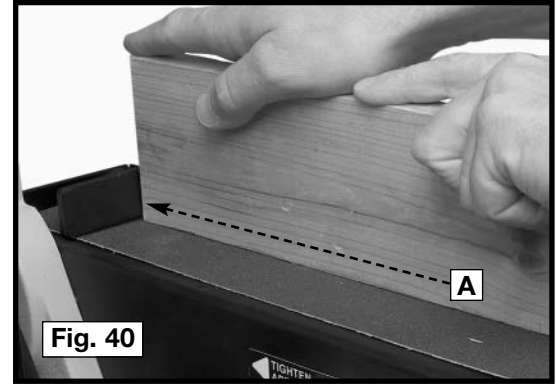
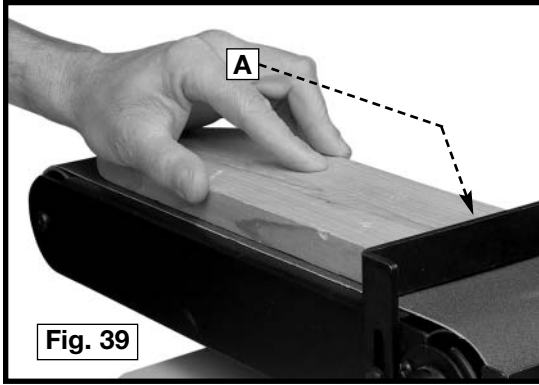

⚠ WARNING To avoid trapping the work or fingers between the backstop and the sanding belt, the edge of the table should be positioned a maximum of 1/16" away from the sanding belt .

SANDING INSIDE AND OUTSIDE CURVES

Sanding inside curves with the sanding belt is illustrated in Fig. 41.

Sanding outside curves with the sanding disc is illustrated in Fig. 42.

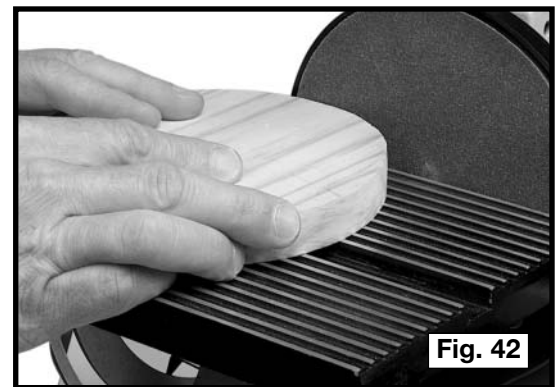
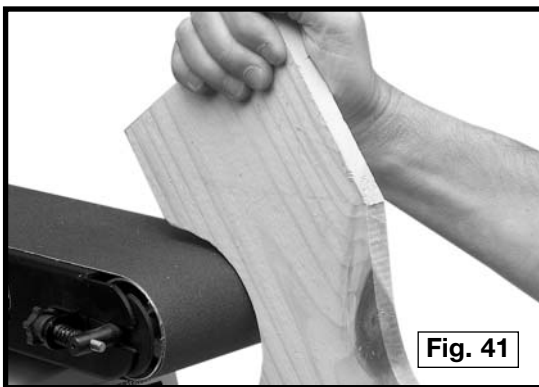

⚠ WARNING Always sand on the left (downward) side of the sanding disc (Fig. 41). Sanding on the right (upward) side of the sanding disc could cause the workpiece to fly up suddenly which could be hazardous.

⚠ WARNING To avoid trapping the work or fingers between the backstop and the abrasive, the edge of the table should be positioned a maximum of 1/16" away from the abrasive .

END SANDING WITH THE BELT

When sanding the ends of wide workpieces, use the sanding belt with the sanding arm in the vertical position and the table assembly moved to the sanding belt (Fig. 43). See the sections “**CHANGING POSITION OF SANDING ARM**” and “**USING TABLE ASSEMBLY WITH SANDING BELT**”.

For more accurate work, use the supplied miter gauge to move the work evenly across the sanding belt (Fig. 43).

⚠ WARNING To avoid trapping the work or fingers between the backstop and the sanding belt, the edge of the table should be positioned a maximum of 1/16" away from the sanding belt .

END SANDING WITH THE DISC

When sanding the ends of narrow workpieces, use the sanding disc and the miter gauge (Fig. 44). Move the work from the center to the left side of the sanding disc.

⚠ WARNING Always sand on the left (downward) side of the sanding disc (Fig. 44). Sanding on the right (upward) side of the sanding disc could cause the workpiece to fly up suddenly which could be hazardous.

⚠ WARNING To avoid trapping the work or fingers between the backstop and the abrasive, the edge of the table should be positioned a maximum of 1/16" away from the abrasive .

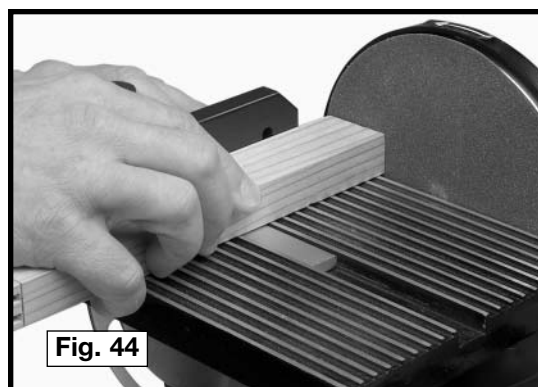

TROUBLESHOOTING

For assistance with your machine, visit our website at www.deltamachinery.com for a list of service centers or call the DELTA Machinery help line at 1-800-223-7278 (In Canada call 1-800-463-3582).

MAINTENANCE

KEEP MACHINE CLEAN

Periodically blow out all air passages with dry compressed air. All plastic parts should be cleaned with a soft damp cloth. NEVER use solvents to clean plastic parts. They could possibly dissolve or otherwise damage the material.

▲WARNING Wear ANSI Z87.1 safety glasses while using compressed air.

FAILURE TO START

Should your machine fail to start, check to make sure the prongs on the cord plug are making good contact in the outlet. Also, check for blown fuses or open circuit breakers in the line.

LUBRICATION

Apply household floor paste wax to the machine table and extension table or other work surface weekly.

PROTECTING CAST IRON FROM RUST

To clean and protect cast iron tables from rust, you will need the following materials: 1 pushblock from a jointer, 1 sheet of medium Scotch-Brite™ Blending Hand Pad, 1 can of WD-40®, 1 can of degreaser, 1 can of TopCote® Aerosol. Apply the WD-40 and polish the table surface with the Scotch-Brite pad using the pushblock as a holddown. Degrease the table, then apply the TopCote® accordingly.

SERVICE



PARTS, SERVICE OR WARRANTY ASSISTANCE

All Delta Machines and accessories are manufactured to high quality standards and are serviced by a network of Porter-Cable • Delta Factory Service Centers and Delta Authorized Service Stations. To obtain additional information regarding your Delta quality product or to obtain parts, service, warranty assistance, or the location of the nearest service outlet, please call 1-800-223-7278 (In Canada call 1-800-463-3582).

ACCESSORIES

A complete line of accessories is available from your Delta Supplier, Porter-Cable • Delta Factory Service Centers, and Delta Authorized Service Stations. Please visit our Web Site www.deltamachinery.com for a catalog or for the name of your nearest supplier.

▲WARNING Since accessories other than those offered by Delta have not been tested with this product, use of such accessories could be hazardous. For safest operation, only Delta recommended accessories should be used with this product.

WARRANTY



Two Year Limited New Product Warranty

Delta will repair or replace, at its expense and at its option, any new Delta machine, machine part, or machine accessory which in normal use has proven to be defective in workmanship or material, provided that the customer returns the product prepaid to a Delta factory service center or authorized service station with proof of purchase of the product within two years and provides Delta with reasonable opportunity to verify the alleged defect by inspection. For all refurbished Delta product, the warranty period is 180 days. Delta may require that electric motors be returned prepaid to a motor manufacturer's authorized station for inspection and repair or replacement. Delta will not be responsible for any asserted defect which has resulted from normal wear, misuse, abuse or repair or alteration made or specifically authorized by anyone other than an authorized Delta service facility or representative. Under no circumstances will Delta be liable for incidental or consequential damages resulting from defective products. This warranty is Delta's sole warranty and sets forth the customer's exclusive remedy, with respect to defective products; all other warranties, express or implied, whether of merchantability, fitness for purpose, or otherwise, are expressly disclaimed by Delta.

PORTER-CABLE • DELTA SERVICE CENTERS (CENTROS DE SERVICIO DE PORTER-CABLE • DELTA)

Parts and Repair Service for Porter-Cable • Delta Machinery are Available at These Locations
(Obtenga Refaccion de Partes o Servicio para su Herramienta en los Siguientes Centros de Porter-Cable • Delta)

ARIZONA

Phoenix 85013-2906
4501 N. 7th Ave.
Phone: (602) 279-6414
Fax: (602) 279-5470

CALIFORNIA

Ontario 91761 (Los Angeles)
3949A East Guasti Road
Phone: (909) 390-5555
Fax: (909) 390-5554

San Diego 92111
7290 Clairemont Mesa Blvd.
Phone: (858) 279-2011
Fax: (858) 279-0362

San Leandro 94577 (Oakland)
3039 Teagarden Street
Phone: (510) 357-9762
Fax: (510) 357-7939

COLORADO

Denver 80223
700 West Mississippi Ave.
Phone: (303) 922-8325
Fax: (303) 922-0245

FLORIDA

Davie 33314 (Miami)
4343 South State Rd. 7 (441)
Unit #107
Phone: (954) 321-6635
Fax: (954) 321-6638

Tampa 33634
4909 West Waters Ave.
Phone: (813) 884-0434
Fax: (813) 888-5997

GEORGIA

Forest Park 30297 (Atlanta)
5442 Frontage Road,
Suite 112
Phone: (404) 608-0006
Fax: (404) 608-1123

ILLINOIS

Addison 60101 (Chicago)
400 South Rohlwing Rd.
Phone: (630) 424-8805
Fax: (630) 424-8895

Woodridge 60517 (Chicago)
2033 West 75th Street
Phone: (630) 910-9200
Fax: (630) 910-0360

KANSAS

Overland Park 66214
9201 Quivira Road
Phone: (913) 495-4330
Fax: (913) 495-4378

MARYLAND

Elkridge 21075 (Baltimore)
7397-102 Washington Blvd.
Phone: (410) 799-9394
Fax: (410) 799-9398

MASSACHUSETTS

Franklin 02038 (Boston)
Franklin Industrial Park
101E Constitution Blvd.
Phone: (508) 520-8802
Fax: (508) 528-8089

MICHIGAN

Madison Heights 48071 (Detroit)
30475 Stephenson Highway
Phone: (248) 597-5000
Fax: (248) 597-5004

MINNESOTA

Eden Prairie 55344
9709 Valley View Road
Phone: (952) 884-9191
Fax: (952) 884-3750

MISSOURI

St. Louis 63146
11477 Page Service Drive
Phone: (314) 997-9100
Fax: (314) 997-9183

NEW YORK

Flushing 11365-1595 (N.Y.C.)
175-25 Horace Harding Expwy.
Phone: (718) 225-2040
Fax: (718) 423-9619

NORTH CAROLINA

Charlotte 28270
9129 Monroe Road, Suite 115
Phone: (704) 841-1176
Fax: (704) 708-4625

OHIO

Columbus 43229
1948 Schrock Road
Phone: (614) 895-3112
Fax: (614) 895-3187

Cleveland 44125
8001 Sweet Valley Drive Unit #19
Phone: (216) 447-9030
Fax: (216) 447-3097

OREGON

Portland 97230
14811 North East Airport Way
Phone: (503) 255-6556
Fax: (503) 255-6543

PENNSYLVANIA

Willow Grove 19090
(Philadelphia)
520 North York Road
Phone: (215) 658-1430
Fax: (215) 658-1433

TEXAS

Carrollton 75006 (Dallas)
1300 Interstate 35 N, Suite 112
Phone: (972) 446-2996
Fax: (972) 446-8157

Houston 77022-2122

536 East Tidwell Rd.
Phone: (713) 692-7111
Fax: (713) 692-1107

WASHINGTON

Auburn 98001 (Seattle)
3320 West Valley HWY, North
Building D, Suite 111
Phone: (253) 333-8353
Fax: (253) 333-9613

Authorized Service Stations are located in many large cities. Telephone **800-438-2486** or **731-541-6042** for assistance locating one. Parts and accessories for Porter-Cable-Delta products should be obtained by contacting any Porter-Cable-Delta Distributor, Authorized Service Center, or Porter-Cable-Delta Factory Service Center. If you do not have access to any of these, call **800-223-7278** and you will be directed to the nearest Porter-Cable-Delta Factory Service Center. Las Estaciones de Servicio Autorizadas están ubicadas en muchas grandes ciudades. Llame al **800-438-2486** ó al **731-541-6042** para obtener asistencia a fin de localizar una. Las piezas y los accesorios para los productos Porter-Cable-Delta deben obtenerse poniéndose en contacto con cualquier distribuidor Porter-Cable-Delta, Centro de Servicio Autorizado o Centro de Servicio de Fábrica Porter-Cable-Delta. Si no tiene acceso a ninguna de estas opciones, llame al **800-223-7278** y le dirigirán al Centro de Servicio de Fábrica Porter-Cable-Delta más cercano.

CANADIAN PORTER-CABLE • DELTA SERVICE CENTERS

ALBERTA

Bay 6, 2520-23rd St. N.E.
Calgary, Alberta
T2E 8L2
Phone: (403) 735-6166
Fax: (403) 735-6144

BRITISH COLUMBIA

8520 Baxter Place
Burnaby, B.C.
V5A 4T8
Phone: (604) 420-0102
Fax: (604) 420-3522

MANITOBA

1699 Dublin Avenue
Winnipeg, Manitoba
R3H 0H2
Phone: (204) 633-9259
Fax: (204) 632-1976

ONTARIO

505 Southgate Drive
Guelph, Ontario
N1H 6M7
Phone: (519) 767-4132
Fax: (519) 767-4131

QUÉBEC

1515 ave.
St-Jean Baptiste, Suite 160
Québec, Québec
G2E 5E2
Phone: (418) 877-7112
Fax: (418) 877-7123

1447, Begin
St-Laurent, (Montréal),
Québec
H4R 1V8
Phone: (514) 336-8772
Fax: (514) 336-3505

The following are trademarks of PORTER-CABLE • DELTA (Las siguientes son marcas registradas de PORTER-CABLE • DELTA S.A.) (Les marques suivantes sont des marques de fabricant de la PORTER-CABLE • DELTA): Auto-Set®, BAMMER®, B.O.S.S.®, Builder's Saw®, Contractor's Saw II™, Delta®, DELTACRAFT®, DELTAGRAM™, Delta Series 2000™, DURATRONIC™, Emc2™, FLEX®, Flying Chips™, FRAME SAW®, Grip Vac™, Homecraft®, INNOVATION THAT WORKS®, Jet-Lock®, JETSTREAM®, 'kickstand', LASERLOC®, MICRO-SET®, Micro-Set®, MIDI LATHE®, MORTEN™, NETWORK™, OMNIJIG®, POCKET CUTTER®, PORTA-BAND®, PORTA-PLANE®, PORTER-CABLE®&(design), PORTER-CABLE®PROFESSIONAL POWER TOOLS, PORTER-CABLE REDEFINING PERFORMANCE™, Posi-Matic®, Q-3®&(design), QUICKSAND®&(design), QUICKSET™, QUICKSET II®, QUICKSET PLUS™, RIPTIDE™&(design), SAFE GUARD II®, SAFE-LOC®, Sanding Center®, SANDTRAP®&(design), SAW BOSS®, Sawbuck™, Sidekick®, SPEED-BLOC®, SPEEDMATIC®, SPEEDTRONIC®, STAIR EASE®, The American Woodshop®&(design), The Lumber Company®&(design), THE PROFESSIONAL EDGE®, THE PROFESSIONAL SELECT®, THIN-LINE™, TIGER®, TIGER CUB®, TIGER SAW®, TORQBUSTER®, TORQ-BUSTER®, TRU-MATCH™, TWIN-LITE®, UNIGUARD®, Unifence®, UNIFEEDER™, Unihead®, Uniplane™, Unirip®, Unisaw®, Univise®, Versa-Feeder®, VERSA-PLANE®, WHISPER SERIES®, WOODWORKER'S CHOICE™.

Trademarks noted with ™ and ® are registered in the United States Patent and Trademark Office and may also be registered in other countries. Las Marcas Registradas con el signo de ™ y ® son registradas por la Oficina de Registros y Patentes de los Estados Unidos y también pueden estar registradas en otros países. PC7.2-0105-149