

# Operator's Manual

# CRAFTSMAN<sup>®</sup>

## 7500 Watt AC Generator

Model No.  
580.327181

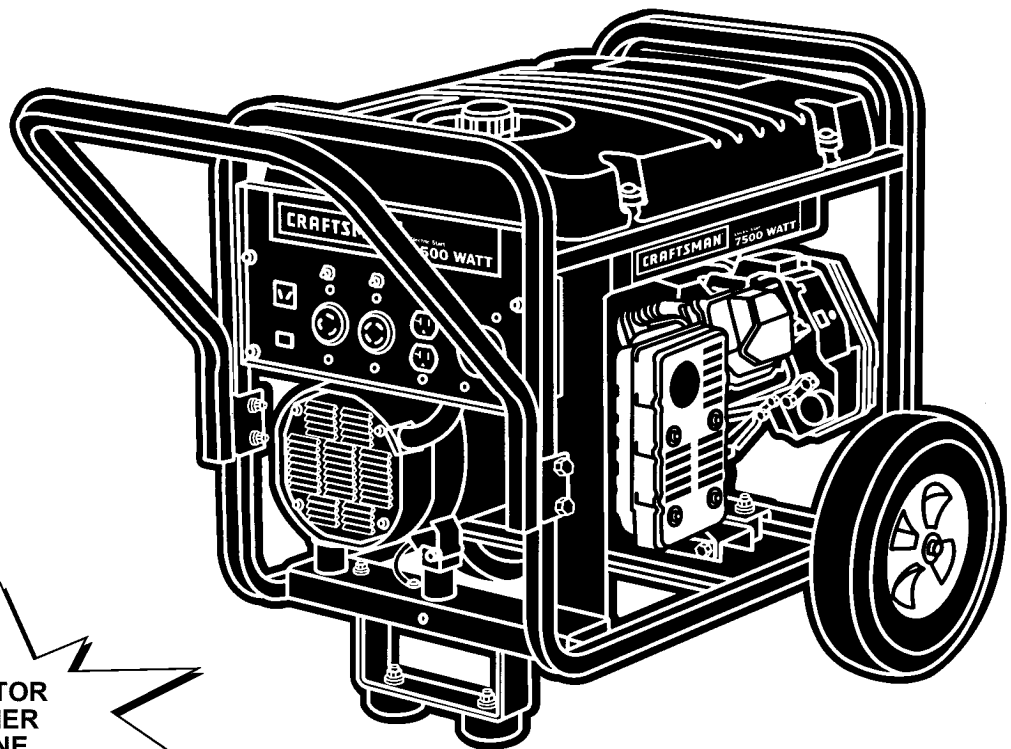

HOURS: Mon. - Fri. 8 a.m. to 5 p.m. (CT)

**CAUTION:** Before using this product, read this manual and follow all Safety Rules and Operating Instructions.

- Safety
- Assembly
- Operation
- Maintenance
- Parts

SEARS, ROEBUCK and CO., Hoffman Estates, IL 60179 U.S.A.  
Visit our Craftsman website: [www.sears.com/craftsman](http://www.sears.com/craftsman)

## TABLE OF CONTENTS

Safety Rules . . . . .	2-3	Storage . . . . .	14
Assembly . . . . .	4-5	Troubleshooting . . . . .	15
Operation . . . . .	6-10	Replacement Parts . . . . .	17-27
Maintenance . . . . .	11-13	HOW TO ORDER PARTS . . . . .	BACK PAGE
Specifications . . . . .	11		

### LIMITED WARRANTY FOR DELUXE PORTABLE GENERATORS

SEARS warrants to the original purchaser that the alternator and engine for its portable generator will be free from defects in materials or workmanship for the items and period set forth below from the date of original purchase. This warranty is not transferable and applies only to portable generators driven by the GN-Series Sears warranted engine.

	<u>CONSUMER*</u>	<u>COMMERCIAL*</u>
<b>Alternator</b>	2 years (2nd year parts only)	1 year
<b>Engine</b>	2 years (2nd year parts only)	1 year

\* **NOTE:** For the purpose of this warranty "Consumer Use" means personal residential household and emergency use by original purchaser, not to be used as a primary source of power. "Commercial Use" means all other uses, including rental, construction, commercial, and income producing purposes. Once a generator has experienced commercial use, it shall thereafter be considered a commercial use generator for the purpose of this warranty.

During said warranty period, SEARS will, at its option, repair or replace any part which, upon examination by SEARS, is found to be defective under normal use and service\*\*. Starting batteries are not warranted by SEARS. All transportation costs under warranty, including return to the factory if necessary, are to be borne by the purchaser and prepaid by him. This warranty does not cover normal maintenance and service and does not apply to a generator set, alternator or engine, or parts which have been subjected to improper or unauthorized installation or alteration, misuse, negligence, accident, overloading, overspeeding, improper maintenance, repair or storage so as, in SEARS's judgment, to adversely affect its performance and reliability.

\*\* **NORMAL WEAR:** As with all mechanical devices, engines need periodic parts service and replacement to perform well. This warranty will not cover repair when normal use has exhausted the life of a part or engine.

THERE IS NO OTHER EXPRESS WARRANTY. SEARS HEREBY DISCLAIMS ANY AND ALL IMPLIED WARRANTIES, INCLUDING BUT NOT LIMITED TO THOSE OF MERCHANTABILITY AND FITNESS FOR A PARTICULAR PURPOSE TO THE EXTENT PERMITTED BY LAW. THE DURATION OF ANY IMPLIED WARRANTIES WHICH CANNOT BE DISCLAIMED IS LIMITED TO THE TIME PERIOD AS SPECIFIED IN THE EXPRESS WARRANTY. LIABILITY FOR CONSEQUENTIAL, INCIDENTAL, OR SPECIAL DAMAGES UNDER ANY AND ALL WARRANTIES IS EXCLUDED. Some provinces do not allow limitations on how long an implied warranty lasts, or the exclusion or limitation of incidental or consequential damages, so the above limitations or exclusions may not apply to you. This warranty gives you specific legal rights and you may also have other rights, which vary from state to state.

For service, see your nearest SEARS authorized warranty service facility. Warranty service can be performed only by a SEARS authorized service facility. This warranty will not apply to service at any other facility. At the time of requesting warranty service, evidence of original purchase date must be presented.

**SEARS, ROEBUCK and CO., D/817WA, Hoffman Estates, IL 60179 U.S.A.**

## SAFETY RULES

 **CAUTION:** Always disconnect spark plug wire and place the wire where it cannot contact the spark plug. To prevent accidental starting when setting up, transporting, adjusting or making repairs to your generator.

 **DANGER:** This generator is designed for outdoor use only. Do not use this generator inside any building or enclosure including the generator compartment of a recreational vehicle (RV). Fire or an explosion may result. No user performed modifications, including venting of exhaust and/or cooling ventilation, will eliminate the danger. Also, allow at least two feet of clearance on all sides of the generator even while operating the unit outdoors.



### WARNING:



The engine exhaust from this product contains chemicals known to the State of California to cause cancer, birth defects, or other reproductive harm.



**CAUTION:** Before using this product, read this manual and follow all Safety Rules and Operating Instructions.

- The generator produces dangerously high voltage that can cause extremely hazardous electrical shock. Avoid contact with bare wires, terminals, etc. Never permit any unqualified person to operate or service the generator.
- Never handle any kind of electrical cord or device while standing in water, while barefoot or while hands or feet are wet. Dangerous electrical shock will result.
- The National Electric Code requires the frame and external electrically conductive parts of generator be properly connected to an approved earth ground. Local electrical codes may also require proper grounding of the generator. Consult with a local electrician for grounding requirements in your area.
- Use a ground fault circuit interrupter in any damp or highly conductive area (such as metal decking or steel work).
- Do not use worn, bare, frayed or otherwise damaged electrical cord sets with the generator. Using any defective cord set may result in electrical shock or damage to equipment and/or property.
- Operate generator only on level surfaces and where it will not be exposed to excessive moisture, dirt, dust or corrosive vapors.
- Gasoline is highly FLAMMABLE and its vapors are EXPLOSIVE. Do not permit smoking, open flames, sparks or heat in the vicinity while handling gasoline. Avoid spilling gasoline on a hot engine. Comply with all laws regulating storage and handling of gasoline.
- Never add fuel while unit is running.
- Do not overfill the fuel tank. Always allow room for fuel expansion. If tank is overfilled, fuel can overflow onto a hot engine and cause FIRE or an EXPLOSION.
- Allow at least 2 feet of clearance on all sides of generator, even while operating unit outdoors, or you could damage the unit.
- Never store generator with fuel in tank where gasoline vapors might reach an open flame or spark or pilot light (as on a furnace, water heater or clothes dryer). FIRE or an EXPLOSION might result.
- Generator exhaust gases contain DEADLY carbon monoxide gas. This dangerous gas, if breathed in sufficient concentrations, can cause unconsciousness or even death. Operate this equipment only in the open air where adequate ventilation is available.
- The engine-generator requires an adequate flow of cooling air for its continued proper operation. Never operate the unit inside any room or enclosure where the free flow of cooling air into and out of the unit might be obstructed. Without sufficient cooling air flow, the unit quickly overheats, damaging the generator or nearby property.
- Never start, or stop, the engine-generator with electrical loads connected to receptacles with the connected devices turned ON. Start the engine and let it stabilize before connecting electrical loads. Disconnect all electrical loads before shutting down the generator.
- Do not insert any object through cooling slots of the engine-generator. You could damage the unit or injure yourself.
- Never operate generator (a) in rain; (b) in any enclosed compartment; (c) if engine speed changes; (d) if connected electrical devices overheat; (e) if electrical output is lost; (f) if engine or generator sparks; (g) if flames or smoke are observed while unit is running; (h) if unit vibrates excessively.

Note: Your generator is equipped with a spark arrestor muffler, the spark arrestor must be maintained in effective working order by the owner/operator.



**LOOK FOR THIS SYMBOL TO POINT OUT IMPORTANT SAFETY PRECAUTIONS. IT MEANS "ATTENTION!!! BECOME ALERT!!! YOUR SAFETY IS INVOLVED."**

# ASSEMBLY

## TO REMOVE GENERATOR FROM CARTON

- Slice two corners at end of carton from top to bottom so the panel can be folded down flat.
- Remove all packing material, carton fillers, etc.
- Remove the generator from the shipping carton.

## CARTON CONTENTS

- Generator
- Wheel Kit
- Locking Plugs
- Battery Tray components
- Manual

Check all contents. If any parts are missing or damaged, call the Generator Helpline at **1-800-222-3136**.

## INSTALLING TRAY AND BATTERY

You must purchase and install a 12 Volt DC battery (Sears DieHard Lawn & Garden Battery #28-27145). The battery should be serviced with electrolyte fluid and fully charged prior to installation. Install the battery as follows:

- Find the battery tray and fasteners shipped loose in the carton. You should have two 7" J bolts, two lock washers, two flat washers and two hex nuts
- Remove the 4 battery tray screws from cradle
- Position the battery tray and install with supplied hardware.

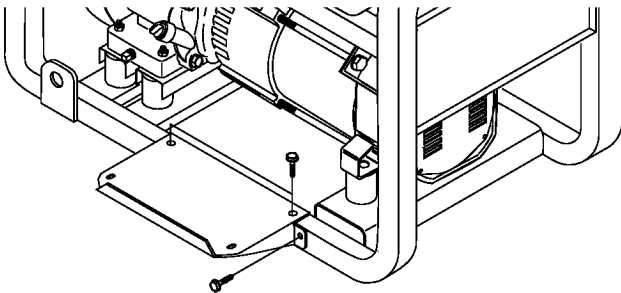

- Set battery onto tray
- Retain battery to tray with two J bolts, two lock washers, two flat washers and two hex nuts.

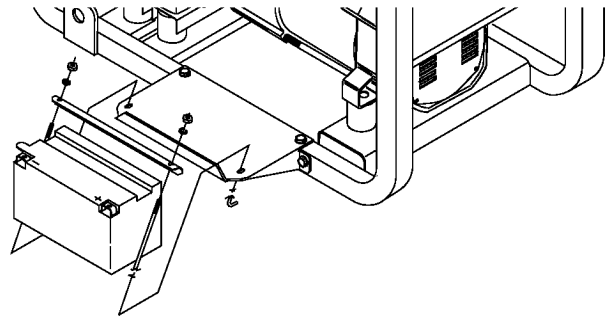

- Connect the red battery cable from the engine starter switch to **positive (+)** terminal on the battery.

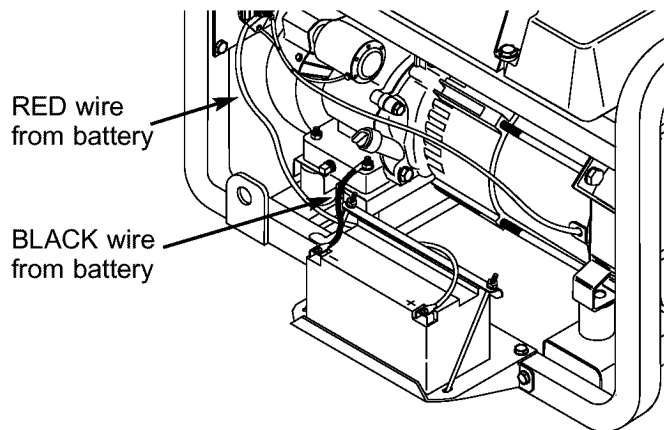

- Connect the black battery cable to the **negative (-)** terminal on the battery.
- Connect the other end of the black cable to the engine, **not the frame**.



**CAUTION:** Be sure the **BLACK** cable is connected to the engine mount and not the frame. You could damage the ground wire.

## ASSEMBLING THE WHEEL KIT

The wheel kit is designed to greatly improve the portability of your generator. You will need a socket wrench with 1/2" or 13mm sockets to install the wheel kit.

Refer to illustration shown below and install the wheel kit as follows:

- Place the generator on a hard flat surface.
- Slide the axle (item 3) through the holes in the brackets provided on the generator cradle and then add the two spacers (item 5) on each protruding end of the axle.
- Stand at the engine end of the generator and gently tilt the generator forward, high enough to place blocks beneath the cradle. This will allow you to add the wheels.
- Slide on the wheels (item 2) and flat washer (item 10) on each end of the axle and insert retaining pin (item 4). Remove the blocks.
- Attach the vibration mounts (item 7) to the support leg (item 6) with two M8 x 30mm capscraws (item 8), M8 washers (item 12) and M8 Lock Nuts (item 9).
- With the Wheels on , you can now tilt the generator end forward and attach the support leg with two M8 x 20mm cap screws (item 11) and two lock nuts (item 9).
- Set the generator down so it is level and attach the handle with four M8x45mm capscraws(item 13) and four lock nuts (item 9).

Wheel Kit Exploded View

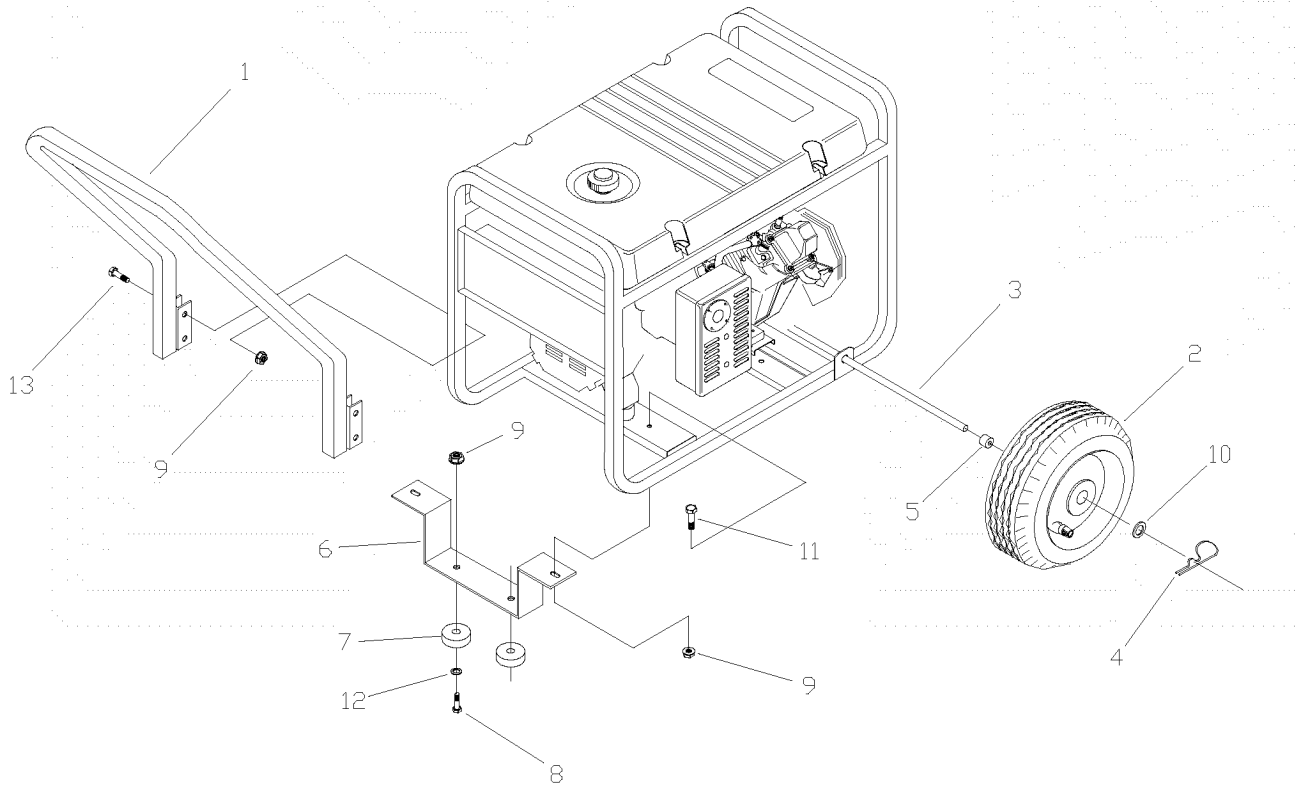

Item	Part #	Qty	Description	Item	Part #	Qty	Description
1	93393A	1	HANDLE	8	42909	2	CAPSCREW, Hex Hd. M8 - 1.25 x 30 Lg.
2	89742	2	WHEEL	9	52858	8	NUT, Lock M8
3	93693A	1	AXLE	10	22247	2	WASHER, Wheel
4	87005	2	PIN, Retaining	11	39253	2	CAPSCREW, Hex Hd. - M8 - 1.25 x 20 Lg.
5	89635	2	SPACER, Wheel	12	22145	2	WASHER, Vibration Mtg.
6	93696	1	LEG, Support	13	39287	4	HHCS, M8 - 1.25 x 45 Lg GR 10.9
7	27007	2	MOUNT, Vibration				

# OPERATION

## CORD SETS AND CONNECTOR PLUGS

### 120 Volt Cord Sets

Use only high quality, well-insulated, extension cords with the generator's 120 Volt type electrical receptacles.

Each receptacle socket is protected against overload by a single 20-Amp push-to-reset type of circuit breaker. Use each receptacle to operate 120 Volts, single phase 60 Hz, AC electrical loads requiring up to 2400 watts (2.4 kW) at 20 Amps of current.

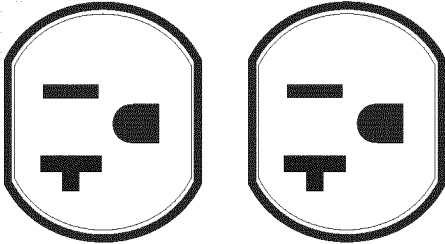

Check the ratings of all extension cords before you use them. Extension cord sets used should be rated 125 Volts at 20 AC Amps or greater for most electrical devices. Some devices, however, may not require this type of extension cord. Check the owner's manuals of those devices for the manufacturer's recommendations.

Keep extension cords as short as possible, preferably less than 15 feet long, to prevent voltage drop and possible overheating of wires.

### 120/240 Volt, 30 AMP Receptacle

This is a full capacity receptacle which means you can take the full rated generator capacity from this receptacle. The outlet is protected by a 30 Amp push-to-reset circuit breaker.

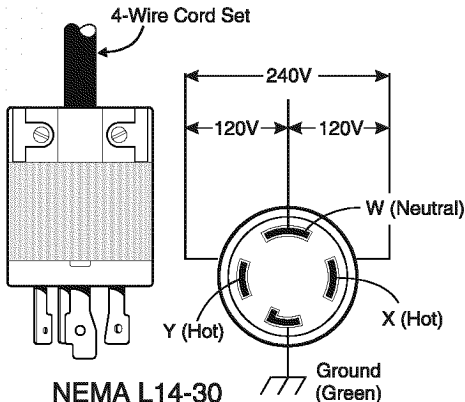

A NEMA L14-30P mating connector plug is required for use with this receptacle. Connect a suitable 4-wire cord set to the plug and to the desired load. The cord set should be rated for 250 Volts at 30 Amps.

Use this receptacle to operate 120/240 Volt AC, 60 Hz single phase loads requiring up to 7200 watts (7.2 kW) of power.

### 120 Volt, 30 AMP Receptacle

Use a NEMA L5-30P type plug with this receptacle. Connect a 3-wire cord set rated for 125 Volts at 30 AC Amps to the plug. Use this receptacle to operate 120 Volt AC, 60 Hz, single phase loads requiring up to 3600 watts (3.6 kW) of power at 30 AC Amps. The outlet is protected by a 30 Amp circuit breaker.

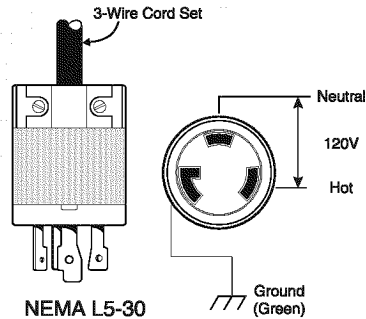

### 240 VOLT, 50 AMP RECEPTACLE

Use a compatible 3 prong plug with this receptacle. Connect a 3-wire cord set rated for 250 Volts at 50 AC Amps to the plug. Use this receptacle to operate 240 Volt AC, 60 Hz single phase loads requiring up to 7,500 watts (7.5 kW) of power.

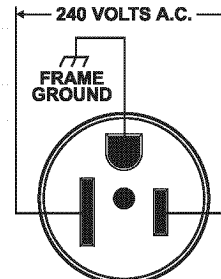

**CAUTION!** Although this outlet states it has a 240 Volt 50-Amp rating (up to 12,000 watts), the generator is rated for 7,500 watts. Powering loads that exceed the generator capacity can damage it or cause serious injuries. 240 Volt loads powered through this outlet should not exceed 31.25 Amps. DO NOT connect 120 Volt AC loads to this receptacle.

### 12 Volt DC Receptacle

This receptacle allows you to recharge a 12 Volt automotive or utility style storage battery with the battery charge cables provided. This receptacle can not recharge 6 Volt batteries and can not be used to crank an engine having a discharged battery. See the sections "Battery Safety" and "Charging a Battery" (page 9) before attempting to recharge a battery.

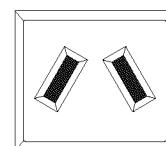

## KNOW YOUR GENERATOR

Read the owner's manual and safety rules before operating your generator.

Compare the illustrations with your generator to familiarize yourself with the locations of various controls and adjustments. Save this manual for future reference.

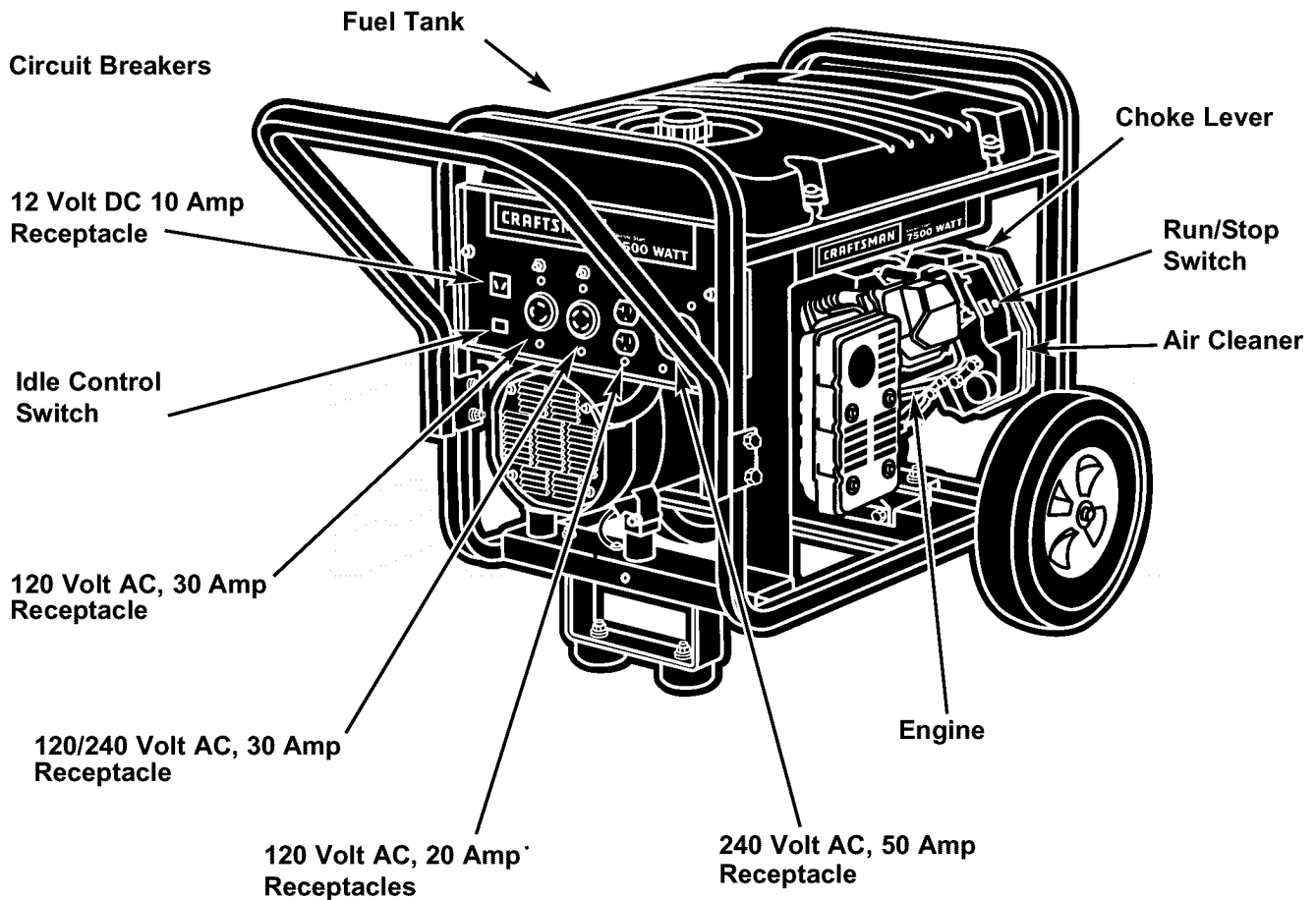

**120/240 Volt AC, 30 Amp Receptacle** — May be used to supply electrical power for the operation of 120 and/or 240 Volt at 30 Amp AC, single phase, 60 Hz electrical lighting, appliance, tool and motor loads.

**120 Volt AC, 30 Amp Receptacle** — May be used to supply electrical power for the operation of 120 Volt at 30 Amp AC, single phase, 60 Hz electrical lighting, appliance, tool and motor loads.

**120 Volt AC, 20 Amp Receptacles** — May be used to supply electrical power for the operation of 120 Volt at 20 Amp AC, single phase, 60 Hz electrical lighting, appliance, tool and motor loads.

**240 Volt AC, 50 Amp Receptacle** — May be used to supply electrical power for the operation of 240 Volt at 31.25 Amp AC, single phase, 60 Hz electrical loads.

**12 Volt DC, 10 Amp Receptacle** — This receptacle allows you to recharge a 12 Volt automotive or utility style storage battery with the charge cables provided.

**15 H.P. Engine** — Provides the power needed to generate 7,500 watts of AC output.

**Air Cleaner** — Filters intake air as it is drawn into the engine.

**Circuit Breakers (AC)** — Circuit breakers are provided for most receptacles to protect the generator against electrical overload. Breakers are "push to reset" type.

**Choke Lever** — Used when starting a cold engine.

**Fuel Tank** — Tank holds 5 U.S. gallons of automotive unleaded gasoline.

**Idle Control Switch** — The idle control runs the engine at normal (high) speeds when there is a load present and runs the engine at idle (low) speeds when a load is not present. This feature greatly improves fuel economy, extends the life of the engine, and reduces engine noise.

**Run/Stop Switch** — Must be in "Run" position to start engine. Set to "Stop" to stop a running engine.

## HOW TO USE YOUR GENERATOR

IF YOU HAVE ANY PROBLEMS operating your generator, please call the generator helpline at **1-800-222-3136**.

## GROUNDING THE GENERATOR

The National Electrical Code requires that the frame and external electrically conductive parts of this generator be properly connected to an approved earth ground. Local electrical codes may also require proper grounding of the unit. For that purpose, a grounding wing nut is provided on the base of the cradle.

Generally, connecting a No. 12 AWG (American Wire Gauge) stranded copper wire to the grounding lug and to an earth-driven copper or brass grounding rod (electrode) provides adequate protection against electrical shock. However, local codes may vary widely. Consult with a local electrician for grounding requirements in your area.

Proper grounding of generator will help prevent electrical shock in the event of a ground fault condition in the generator or in connected electrical devices. Proper grounding also helps dissipate static electricity, which often builds up in ungrounded devices.

## CONNECTING ELECTRICAL LOADS

- Let engine stabilize and warm up for a few minutes after starting.
- **Do not** connect 240 Volts to 120 Volt duplex receptacles
- **Do not** connect 3-phase loads to receptacles.
- Plug in and turn on the desired 120 and/or 240 Volt, single phase, 60 Hertz, AC electrical loads. **DO NOT OVERLOAD THE GENERATOR.** Add up the rated watts (or Amps) of all loads to be connected at one time. This total should not be greater than the rated wattage/ampere capacity of the generator. See Don't Overload the Generator on Page 10.

## BEFORE STARTING THE GENERATOR

To operate the engine you will need to do the following:

### Add Engine Oil

**NOTE:** When adding oil to the engine crankcase in the future, use only high quality detergent oil rated with API service classification SF or SG rated SAE 30 weight. Use no special additives. Select the oil's viscosity grade according to your expected operating temperature.

Although multi-viscosity oils (5W30, 10W30, etc.) improve starting in cold weather, these multi-viscosity oils will result in increased oil consumption when used above 32°F. Check your engine oil level more frequently to avoid possible damage from running low on oil.

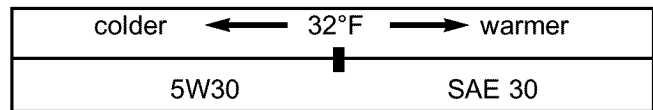

- Place generator on a level surface and remove the yellow oil fill cap and add engine oil until level is at point of overflowing. Check engine oil level before starting each time thereafter.

## Add Gasoline

**WARNING NEVER fill fuel tank indoors. NEVER fill fuel tank when engine is running or hot. DO NOT light a cigarette or smoke when filling the fuel tank.**

**CAUTION: Do not overfill the fuel tank. Always leave room for expansion.**

- Use regular UNLEADED gasoline with the generator engine.

**IMPORTANT:** It is important to prevent gum deposits from forming in essential fuel system parts such as the carburetor, fuel filter, fuel hose or tank during storage. Also, experience indicates that alcohol-blended fuels (called gasohol, ethanol or methanol) can attract moisture which leads to separation and formation of acids during storage. Acidic gas can damage the fuel system of an engine while in storage. To avoid engine problems, the fuel system should be emptied before storage of 30 days or longer. See "Storage" on page 14. Never use engine or carburetor cleaner products in the fuel tank or permanent damage may occur.

## TO START THE ENGINE

- Unplug all electrical loads from generator receptacles before starting the engine. **NEVER** start or stop engine with electrical devices plugged into the panel receptacles and turned on.
- Make sure the idle control switch is "Off".

**CAUTION! Never run engine indoors or in enclosed poorly ventilated areas. Engine Exhaust contains carbon monoxide, an odorless and deadly gas.**

**WARNING! Temperature of muffler and nearby areas may exceed 150°F (65°C). Avoid these areas.**

- Open the fuel valve.
- \* Place the Run/Stop Switch in the "RUN" position.
- Move engine CHOKE LEVER to "FULL CHOKE POSITION."
- **For manual starting:** Grasp starter grip and pull slowly until you feel some resistance. Then pull cord out with rapid full arm stroke. Let rope return slowly. Do not let rope "snap back" against starter.
- **For electric starting:** Press start switch on generator cradle until engine cranks. Keep pressing until it starts.



- When engine starts, move choke lever to “**1/2 Choke Position**” until the engine runs smoothly and then to “**Run Position.**” If engine falters, move choke lever to “**1/2 Choke Position**” until the engine runs smoothly and then to “**Run Position.**”

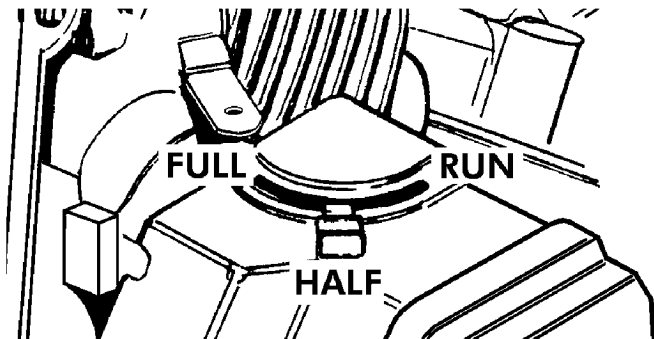

**Note:** If engine fails to start after 3 pulls, move the choke lever to “**Run Position**” and pull starter rope again.

**Note:** If engine fires, but does not continue to run, move choke lever to “**Full Choke**” and repeat starting instructions.

## STOPPING THE ENGINE

- Unplug **all** electrical loads from generator panel receptacles. **Never** start or stop engine with electrical devices plugged in and turned on.
- Turn “**Off**” the idle control switch if on.
- Let engine run at no-load for several minutes to stabilize the internal temperatures of engine and generator.
- Move Run/Stop switch to “**Stop**” position.
- Close fuel valve.

## OPERATING AUTOMATIC IDLE CONTROL

This switch is designed to greatly improve fuel economy. When this switch is turned “**On**”, the engine will only run at its normal high governed engine speed when an electrical load is connected. When an electrical load is removed, the engine will run at a reduced speed. With the switch “**Off**”, the engine will run at the normal high engine speed. Always have the switch off when starting and stopping the engine.

## LOW OIL PRESSURE SHUTDOWN SYSTEM

The engine is equipped with a low oil pressure sensor that shuts down the engine automatically when the oil pressure drops below 6 psi. If the engine shuts down by itself and the fuel tank has enough gasoline, check engine oil level.

### Initial Start-up

A delay built in the low oil shutdown system allows oil pressure to build during starting. The delay allows the engine to run for about 10 seconds before sensing oil pressure.

## Sensing Low Pressure

If the system senses low oil pressure during operation, the engine shuts down. As the system shuts down, the low oil light comes ON. However, once the engine has stopped rotating, this light will go OFF.

## Restarting

If you try to restart the engine within 10 seconds after it shuts down, the engine may NOT start. The system needs 5 to 10 seconds to reset.

If you do restart the engine after such a shutdown and have not corrected the low oil pressure, the engine runs for about 10 seconds as described above and then stops.

## BATTERY SAFETY

**⚠ DANGER: Storage batteries give off explosive hydrogen gas while recharging. An explosive mixture will remain around the battery for a long time after it has been charged. The slightest spark can ignite the hydrogen and cause an explosion. Such an explosion can shatter the battery and cause blindness or other serious injury.**

**⚠ DANGER: Do not permit smoking, open flame, sparks or any other source of heat around a battery. Wear protective goggles, rubber apron and rubber gloves when working around a battery. Battery electrolyte fluid is an extremely caustic sulfuric acid solution that can cause severe burns. If spill occurs flush area with clear water immediately.**

## CHARGING A BATTERY

Your generator has the capability of recharging a discharged 12 Volt automotive or utility style storage battery. **Do not use the unit to charge any 6 Volt batteries. Do not use the unit to crank an engine having a discharged battery.**

**To recharge 12 Volt batteries, proceed as follows:**

- Check fluid level in all battery cells. If necessary, add **ONLY** distilled water to cover separators in battery cells. **Do not use tap water.**
- If the battery is equipped with vent caps, make sure they are installed and are tight.
- If necessary, clean battery terminals.
- Connect battery charge cable connector plug to panel receptacle identified by the words “**12 VOLT D.C.**”
- Connect battery charge cable clamp with **red** handle to the **positive (+)** battery terminal
- Connect battery charge cable clamp with **black** handle to the **negative (-)** battery terminal.

- Start engine. Let the engine run while battery recharges.
- When battery has charged, shut down engine

**NOTE:** Use an automotive hydrometer to test battery state of charge and condition. Follow the hydrometer manufacturer's instructions carefully. Generally, a battery is considered to be at 100% state of charge when specific gravity of its fluid (as measured by hydrometer) is 1.260 or higher.

### DON'T OVERLOAD THE GENERATOR

Overloading a generator in excess of its rated wattage capacity can result in damage to the generator and to connected electrical devices. Observe the following, to prevent overloading the unit:

- Add up the total wattage of all electrical devices to be connected at one time. This total should NOT be greater than the generator's wattage capacity.

- The rated wattage of lights can be taken from light bulbs. The rated wattage of tools, appliances and motors can usually be found on a data plate or decal affixed to the device.
- If the appliance, tool or motor does not give wattage, multiply volts times ampere rating to determine watts (volts x amps = watts).
- Some electric motors, such as induction types, require about three times more watts of power for starting than for running. This surge of power lasts only a few seconds when starting such motors. Make sure you allow for this high starting wattage when selecting electrical devices to connect to your generator. First, figure the watts needed to start the largest motor. Add to that figure the running watts of all other connected loads.

The Wattage Reference Guide below is provided to assist you in determining how many items your generator can operate at one time.

### WATTAGE REFERENCE GUIDE

	RUNNING WATTS		RUNNING WATTS
*Air Conditioner (12,000 Btu).....	1700	Impact Wrench.....	500
Battery Charger (20 Amp).....	500	*Jet Pump.....	800
Belt Sander (3").....	1000	Lawn Mower.....	1200
Chain Saw.....	1200	Light Bulb.....	100
Circular Saw (6-1/2").....	800 to 1000	Microwave Oven.....	700
Coffee Maker.....	1000	*Milk Cooler.....	1100
*Compressor (1 HP).....	2000	Oil Burner on Furnace.....	300
*Compressor (3/4 HP).....	1800	Oil Fired Space Heater (140,000 Btu).....	400
*Compressor (1/2 HP).....	1400	Oil Fired Space Heater (85,000 Btu).....	225
Curling Iron.....	700	Oil Fired Space Heater (30,000 Btu).....	150
*Freezer.....	500	*Paint Sprayer, Airless (1/3 HP).....	600
Disc Sander (9").....	1200	Paint Sprayer, Airless (handheld).....	150
Edge Trimmer.....	500	Radio.....	50 to 200
Electric Nail Gun.....	1200	*Refrigerator.....	600
Electric Range (one element).....	1500	Slow Cooker.....	200
Electric Skillet.....	1250	*Submersible Pump (1-1/2 HP).....	2800
*Furnace Fan (1/3 HP).....	1200	*Submersible Pump (1 HP).....	2000
Hair Dryer.....	1200	*Submersible Pump (1/2 HP).....	1500
Hand Drill (1").....	1100	Sump Pump.....	600
Hand Drill (1/2").....	750 to 1000	*Table Saw (10").....	1750 to 2000
Hand Drill (3/8").....	500	Television.....	200 to 500
Hand Drill (1/4").....	250	Weed Trimmer.....	500
Hedge Trimmer.....	450		

\* Allow 3 times the listed watts for starting these devices.

# MAINTENANCE

## MAINTENANCE SCHEDULE

Follow the hourly or calendar intervals, whichever occurs first.

More frequent service is required when operating in adverse conditions noted below.

Maintenance Operation	Every 8 Hours or Daily	25 Hours or Every Season	50 Hours or Every Season	100 Hours or Every Season	Yearly
Check oil level	X				
Change oil and oil filter‡			X*		
Clean Spark Arrestor Screen				X	
Service air cleaner pre-cleaner		X**			
Service air cleaner cartridge			X**		
Adjust Valve Clearance			X		
Replace spark plugs					X
Retorque head bolts			***		
	‡ Change oil after first 8 hours of operation then after every 50 hours or every season.				
	* Change oil and oil filter every 25 hours when operating under heavy load or in high temperatures.				
	** Clean more often under dirty or dusty conditions. Replace Cleaner parts if very dirty.				
	*** Perform this task only after first 50 hours of operation. Head bolts will not need further re-torquing.				

### PRODUCT SPECIFICATIONS

#### Generator Specifications

Rated Maximum Power . . . . . 7500 Watts (7.5kW)  
 Rated Voltage . . . . . 120/240 Volts AC  
 Rated Maximum Current  
 at 240 Volts . . . . . 31.2 AC Amperes  
 Rated Maximum Current  
 at 120 Volts . . . . . 62.5 AC Amperes  
 Rated Frequency . . . . . 60 Hz at 3600 rpm  
 Phase . . . . . Single Phase

#### Engine Specifications

Rated Horsepower . . . . . 15 at 3600 rpm  
 Displacement . . . . . 410 cc  
 Spark Plug  
 Type: . . . . . Champion RC12YC or  
 Equivalent  
 Set Gap To: . . . . . 0.030inch (0.76mm)  
 Gasoline Capacity . . . . . 5 U.S. gallons  
 Oil  
 Summer . . . . . SAE 30 (10W-30)  
 Winter . . . . . SAE 5W-20 or 5W-30

### GENERAL RECOMMENDATIONS

The warranty of the generator does not cover items that have been subjected to operator abuse or negligence. To receive full value from the warranty, operator must maintain generator as instructed in this manual.

Some adjustments will need to be made periodically to properly maintain your generator.

All adjustments in the Service and Adjustments section of this manual should be made at least once each season. Follow the requirements in the “Maintenance Schedule” chart above.

**Note:** Once a year you should clean or replace the spark plug and replace the air filter. A new spark plug and clean air filter assure proper fuel-air mixture and help your engine run better and last longer.

### GENERATOR MAINTENANCE

Generator maintenance consists of keeping the unit clean and dry. Operate and store the unit in a clean dry environment where it will not be exposed to excessive dust, dirt, moisture or any corrosive vapors. Cooling air slots in the generator must not become clogged with snow, leaves, or any other foreign material.

Check the cleanliness of the generator frequently and clean when dust, dirt, oil, moisture or other foreign substances are visible on its exterior surface.

**Note:** We **DO NOT** recommend using a garden hose to clean generator. Water can enter the engine fuel system and cause problems. In addition, if water enters the generator through cooling air slots, some of the water will be retained in voids and cracks of the rotor and stator winding insulation. Water and dirt buildup on the generator internal windings will eventually decrease the insulation resistance of these windings.

## TO CLEAN THE GENERATOR:



**CAUTION:** Never Insert any object or tool through the air cooling slots, even if the engine is not running.

- Use a damp cloth to wipe exterior surfaces clean.
- A soft, bristle brush may be used to loosen caked on dirt, oil, etc.
- A vacuum cleaner may be used to pick up loose dirt and debris.
- Low pressure air (not to exceed 25 psi) may be used to blow away dirt. Inspect cooling air slots and openings on the generator. These openings must be kept clean and unobstructed.

## ENGINE MAINTENANCE



**DANGER:** When working on the generator always disconnect spark plug wire from spark plug and keep it away from spark plug.

### CHECKING OIL LEVEL

Oil level should be checked prior to each use or at least every 8 hours of operation. Keep oil level maintained.

### CHANGING ENGINE OIL AND OIL FILTER

Change oil after first 8 hours of operation. Change oil and oil filter every 50 hours thereafter. If you are using your generator under extremely dirty or dusty conditions, or in extremely hot weather, change oil more often.

Change oil while engine is still warm from running, as follows:

- Clean area around oil drain plug.
- Remove oil drain plug and oil fill plug and drain oil completely into a suitable container.
- When oil has completely drained, Install oil drain plug and tighten securely.
- Place a suitable container beneath the oil filter and turn filter counterclockwise to remove. Discard according to local regulations.
- Coat gasket of new filter (p/n 70185) with engine oil. turn filter clockwise until gasket contacts tightly with filter adapter. Then tighten an additional 3/4 turn.
- Fill oil sump with recommended oil. (See "Before Starting the Engine" on page 8 for oil recommendations)
- Install the oil fill plug and tighten securely.
- Wipe up any spilled oil.

### CLEAN/REPLACE SPARK PLUG

Change the spark plug every 100 hours of operation or once each year, whichever comes first. This will help your engine to start easier and run better. Replace with Champion RC12YC or equivalent.

- Clean area around spark plug.
- Remove and inspect spark plug.
- Replace spark plug if electrodes are pitted, burned or porcelain is cracked. For Replacement use Champion RC12YC or equivalent.
- Check electrode gap with wire feeler gauge and set spark plug gap to 0.030 inch (0.76mm) if necessary.

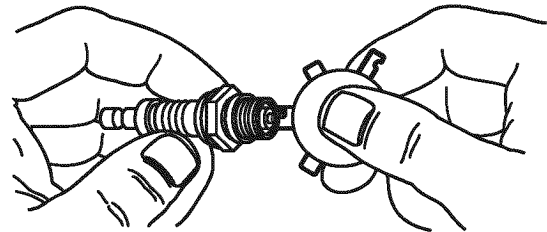

### RETORQUE HEAD BOLTS

After the first 50 hours of operation, you must retorquer the head bolts 6.9 kg.-m. (44 ft.-lbs.)

**Important:** If you feel uncomfortable about doing this procedure or you don't have the proper tools, please take your generator in to the nearest service center to have the head bolts re-torqued. This is a very important step to insure the longest life for your engine.

**NOTE:** Only perform this adjustment after the first 50 hours of operation. The head bolts will need no further adjustment.

- Torque sequence is as follows: A, B, C, D, (alternating pattern).

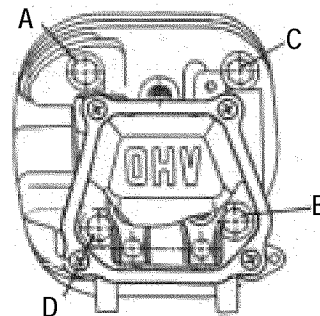

### SERVICE AIR CLEANER

Your engine will not run properly and may be damaged if you run it using a dirty air cleaner. Clean or replace the air cleaner paper filter once every 50 hours of operation or once a year, whichever comes first. Clean or replace more often if operating under dusty conditions. Clean foam pre-cleaner every 25 hours of operation or sooner under dusty conditions.

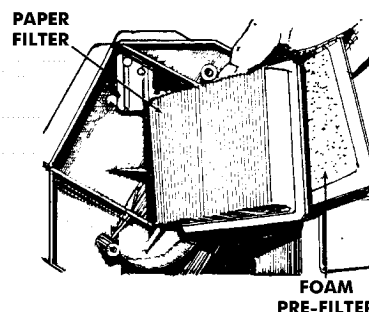

## To clean or replace foam pre-cleaner:

- Remove air cleaner cover, then foam pre-filter.
- Wash pre-cleaner in soapy water. Squeeze pre-filter dry in clean cloth (DO NOT TWIST).
- Clean air cleaner cover before installing it.

To clean or replace paper air filter:

- Remove air cleaner cover; then remove foam pre-filter (service if necessary) and remove paper filter.
- Clean paper filter by tapping it gently on a solid surface. If the filter is too dirty, replace it with a new one. Dispose of the old filter properly.
- Clean air cleaner cover then insert pre-cleaner into cover. Next insert new paper filter into cover to hold pre-cleaner in place and assemble all of them to the base of the air cleaner.

Note: If you need to order a new air filter, please call **1-800-366-PART**.

## CLEAN SPARK ARRESTOR SCREEN

The engine exhaust muffler has a spark arrestor screen. Inspect and clean the screen every 100 hours of operation or once each year, whichever comes first.

**NOTE:** If you use your generator on any forest-covered, brush-covered or grass-covered unimproved land, it must have a spark arrestor. The spark arrestor must be maintained in good condition by the owner/operator.

Clean and inspect the spark arrestor as follows:

- To remove the muffler guard from the muffler, remove the four screws that connect the guard to the muffler bracket.

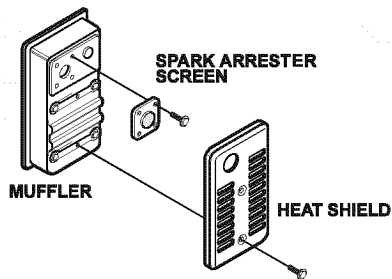

- Remove four screws that attach the spark arrestor screen.
- Inspect screen and replace if torn, perforated or otherwise damaged. DO NOT USE a defective screen. If screen is not damaged, clean it with commercial solvent.
- Reattach the screen and the muffler guard.

## ADJUSTING VALVE CLEARANCE

After the first 50 hours of operation, you should adjust the valve clearance in the engine.

**Important:** If you feel uncomfortable about doing this procedure or you don't have the proper tools, please take your generator in to the nearest service center to have the valve clearance adjusted. This is a very important step to insure longest life for your engine.

## To adjusting valve clearance:

- Make sure the engine is at room temperature
- Make sure that the spark plug wire is removed from the spark plug and out of the way.
- Remove the breather tube from the valve cover.
- Remove the four screws attaching the valve cover with a #2 or 3 phillips screwdriver.
- Make sure the piston is at Top Dead Center (TDC) of its compression stroke (both valves closed). To get the piston at top dead center, pull on the recoil handle slowly watching the piston trough the spark plug hole. As you pull on the recoil handle the piston should move up and down. The piston is put Top Dead Center when it is up as high as it can go.

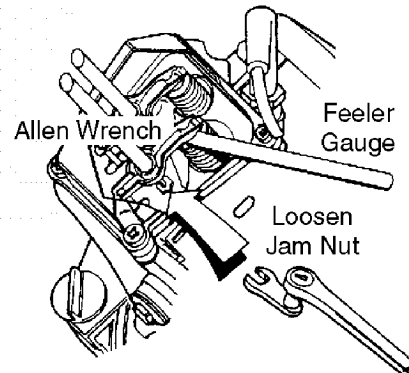

- Loosen the rocker arm jam nut. Use an 8mm allen wrench to turn the pivot ball stud while checking clearance between the rocker arm and the valve stem with a feeler gauge. Correct clearance is 0.002-0.004 inch (0.05-0.1mm). Note: You must hold the rocker arm jam nut in place as you turn the pivot ball stud.
- When valve clearance is correct, hold the pivot ball stud in place with the allen wrench and tighten the rocker arm jam nut. Tighten the jam nut to 165-183 inch-pounds torque. After tightening the jam nut, recheck valve clearance to make sure it did not change.

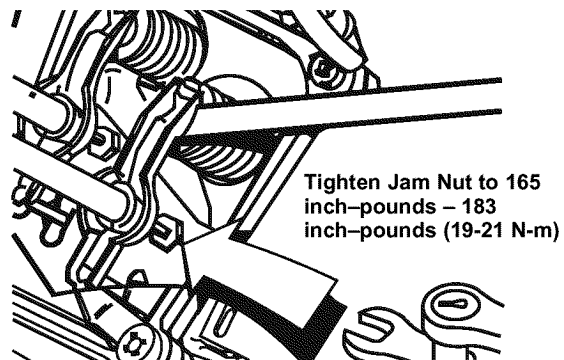

- Reattach the valve cover. **Note:** Start all four screws before tightening or you will not be able to get all the screws in place. **Note:** Make sure the gasket between the valve cover and cylinder head is in place.
- Reattach the breather tube.
- Reattach the spark plug wire to the spark plug.

# STORAGE

## GENERAL

The generator should be started at least once every seven days and allowed to run at least 30 minutes. If this cannot be done and you must store the unit for more than 30 days, use the following information as a guide to prepare it for storage.

**⚠ WARNING: NEVER store engine with fuel in tank indoors or in enclosed, poorly ventilated areas where fumes may reach an open flame, spark or pilot light as on a furnace, water heater, clothes dryer or other gas appliance.**

## LONG TERM STORAGE INSTRUCTIONS

It is important to prevent gum deposits from forming in essential fuel system parts such as the carburetor, fuel filter, fuel hose or tank during storage. Also, experience indicates that alcohol-blended fuels (called gasohol, ethanol or methanol) can attract moisture which leads to separation and formation of acids during storage. Acidic gas can damage the fuel system of an engine while in storage.

To avoid engine problems, the fuel system should be emptied before storage of 30 days or longer. Follow these instructions:

**⚠ WARNING: Drain fuel into approved container outdoors, away from open flame. Be sure engine is cool. Do not smoke.**

### Protect Fuel System

- Remove all gasoline from the fuel tank to prevent gum deposits from forming on these parts and causing possible malfunction of engine.
- Run engine until engine stops from lack of fuel.

## Change Oil

While engine is still warm, drain oil from crankcase. Refill with recommended grade.

## Oil Cylinder Bore

**⚠ CAUTION! Avoid spray from spark plug hole when cranking engine slowly.**

- Remove spark plug and pour about 1/2 ounce (15ml) of engine oil into the cylinder. Cover spark plug hole with rag. Crank slowly to distribute oil.
- Install spark plug. Do not connect spark plug wire.

## GENERATOR:

- Clean the generator as outlined on Page 11 ("To Clean the Generator").
- Check that cooling air slots and openings on generator are open and unobstructed.

## OTHER STORAGE TIPS:

- Do not store gasoline from one season to another.
- Replace your gasoline can if your can starts to rust. Rust and/or dirt in your gasoline will cause problems.
- If possible, store your unit indoors and cover it to give protection from dust and dirt. **BE SURE TO EMPTY THE FUEL TANK.**
- Cover your unit with a suitable protective cover that does not retain moisture.
- Store generator in clean, dry area.

**IMPORTANT: NEVER** cover your generator while engine and exhaust area are warm.

# TROUBLESHOOTING

<b>Problem</b>	<b>Cause</b>	<b>Correction</b>
Engine is running, but no AC output is available.	<ol style="list-style-type: none"> <li>1. One of the circuit breakers is open.</li> <li>2. Fault in generator.</li> <li>3. Poor connection or defective cord set.</li> <li>4. Connected device is bad.</li> </ol>	<ol style="list-style-type: none"> <li>1. Reset circuit breaker.</li> <li>2. Contact Sears Service Facility.</li> <li>3. Check and repair.</li> <li>4. Connect another device that is in good condition.</li> </ol>
Engine runs good at no-load but "bogs down" when loads are connected	<ol style="list-style-type: none"> <li>1. Short circuit in a connected load.</li> <li>2. Engine speed is too slow.</li> <li>3. Generator is overloaded.</li> <li>4. Shorted generator circuit.</li> </ol>	<ol style="list-style-type: none"> <li>1. Disconnect shorted electrical load.</li> <li>2. Contact Sears Service Facility.</li> <li>3. See "Don't Overload the Generator"</li> <li>4. Contact Sears Service Facility.</li> </ol>
Engine will not start; or starts and runs rough.	<ol style="list-style-type: none"> <li>1. Run/Stop Switch set to STOP.</li> <li>2. Dirty air cleaner</li> <li>3. Out of gasoline.</li> <li>4. Stale gasoline.</li> <li>5. Spark plug wire not connected to spark plug.</li> <li>6. Bad spark plug.</li> <li>7. Water in gasoline.</li> <li>8. Overchoking.</li> <li>9. Low oil level</li> <li>10. Excessively rich fuel mixture.</li> <li>11. Intake valve stuck open or closed.</li> <li>12. Engine has lost compression.</li> </ol>	<ol style="list-style-type: none"> <li>1. Set switch to RUN.</li> <li>2. Clean or replace air cleaner.</li> <li>3. Fill fuel tank.</li> <li>4. Drain gas tank; fill with fresh fuel.</li> <li>5. Connect wire to spark plug.</li> <li>6. Replace spark plug.</li> <li>7. Drain gas tank; fill with fresh fuel.</li> <li>8. Open choke fully and crank engine.</li> <li>9. Fill crankcase to proper level.</li> <li>10. Contact Sears Service Facility.</li> <li>11. Contact Sears Service Facility.</li> <li>12. Contact Sears Service Facility.</li> </ol>
Engine shuts down during operation	<ol style="list-style-type: none"> <li>1. Out of gasoline.</li> <li>2. Low oil level.</li> </ol>	<ol style="list-style-type: none"> <li>1. Fill fuel tank.</li> <li>2. Fill crankcase to proper level.</li> </ol>
Engine lacks power.	<ol style="list-style-type: none"> <li>1. Load is too high.</li> <li>2. Dirty air filter.</li> </ol>	<ol style="list-style-type: none"> <li>1. See "Don't Overload the Generator"</li> <li>2. Replace air filter.</li> </ol>
Engine "hunts" or falters.	<ol style="list-style-type: none"> <li>1. Choke is opened too soon.</li> <li>2. Carburetor is running too rich or too lean.</li> </ol>	<ol style="list-style-type: none"> <li>1. Move choke to halfway position until engine runs smoothly.</li> <li>2. Contact Sears Service Facility.</li> </ol>
No battery charge DC output	<ol style="list-style-type: none"> <li>1. Battery posts are corroded.</li> <li>2. Battery fluid level is low.</li> <li>3. Battery cable is bad.</li> <li>4. Battery is defective.</li> <li>5. Receptacle is bad.</li> </ol>	<ol style="list-style-type: none"> <li>1. Clean battery posts</li> <li>2. Add distilled water to battery.</li> <li>3. Replace cable.</li> <li>4. Check battery condition; replace if defective.</li> <li>5. Contact Sears Service Facility.</li> </ol>

# NOTES

---

---

---

---

---

---

---

---

---

---

---

---

---

---

---

---

---

---

---

---

---

---

---

---

---

---

---

---

---



# PARTS

## CRAFTSMAN 7500 Watt AC Generator 580.327181 Wiring Diagram

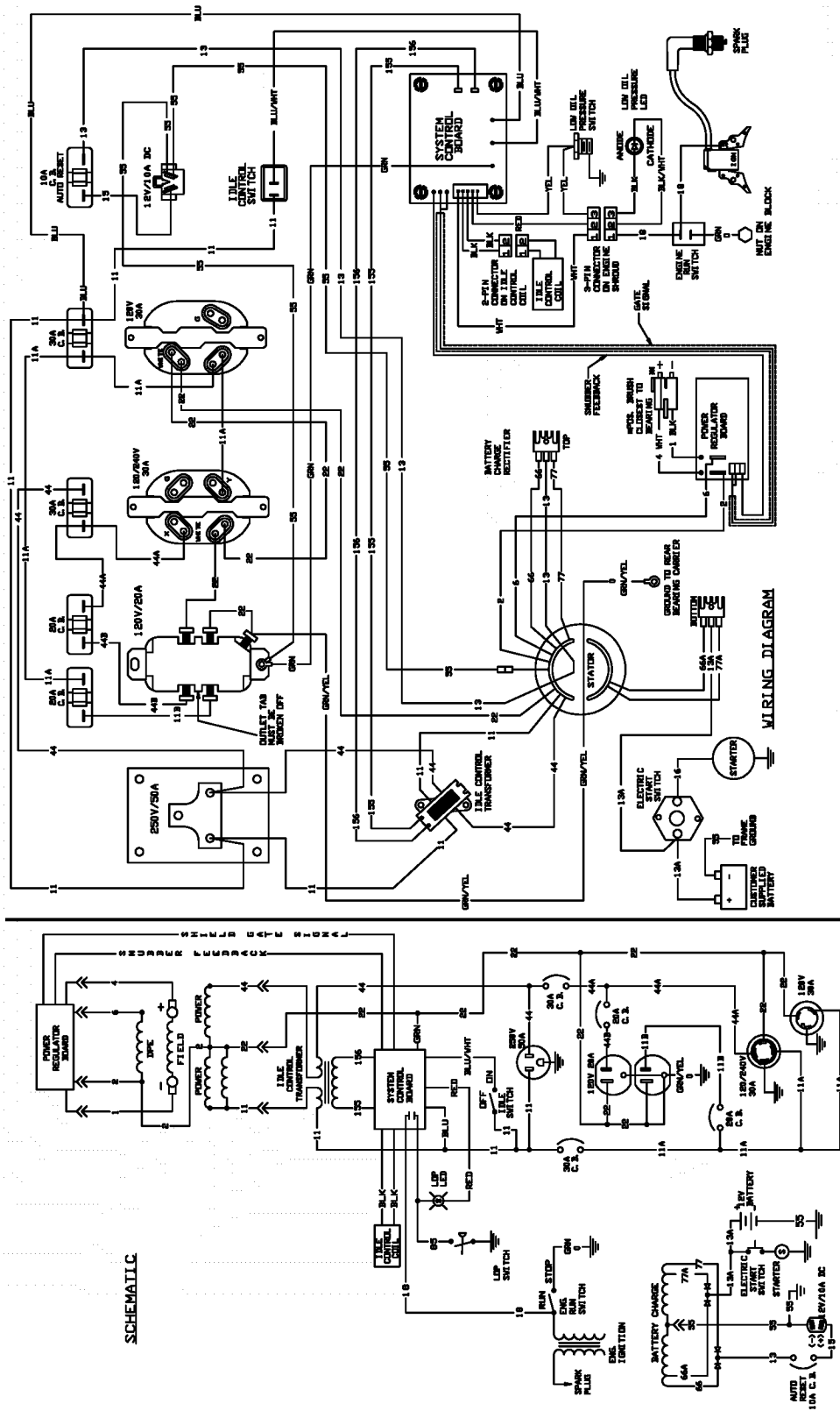

**CRAFTSMAN 7500 Watt AC Generator 580.327181**  
**Main Unit — Exploded View**

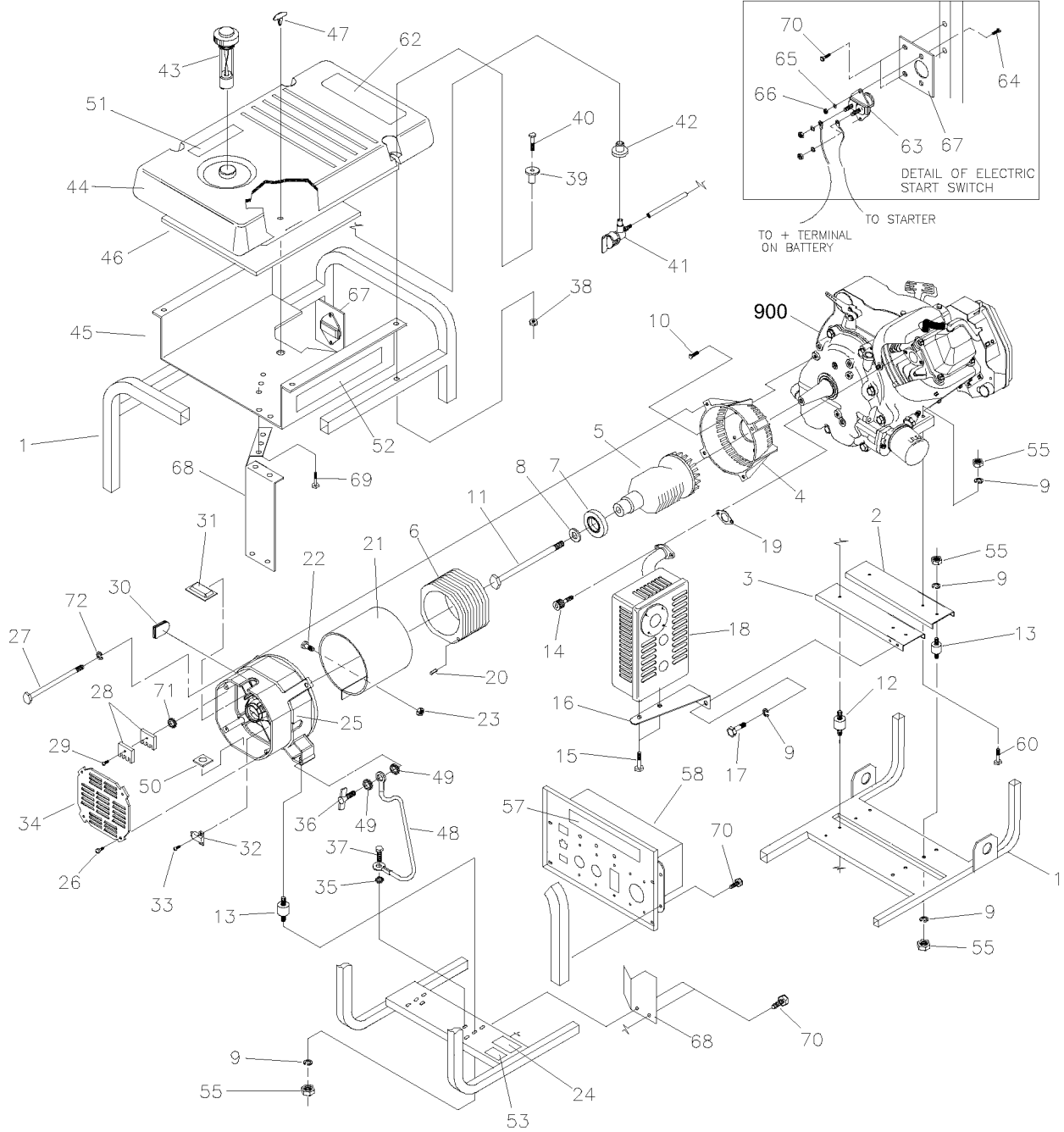

# CRAFTSMAN 7500 Watt AC Generator 580.327181

## Main Unit — Parts List

ITEM	PART #.	QTY.	DESCRIPTION	ITEM	PART #.	QTY.	DESCRIPTION
1	92432	1	CRADLE	47	85000	1	CLIP, Insulation
2	92531	1	SUPPORT, Engine	48	143-53621	1	WIRE, Ground
3	92731	1	SUPPORT, Engine & Muffler	49	26850	2	LW, EXT, M6 Shakeproof
4	92247	1	HOUSING, Engine Adapter	50	57593	1	MOUNT, Cable Tie
5	B1342G	1	ASSEMBLY, Rotor	51	92982	1	DECAL, Danger
6	B1897G	1	ASSEMBLY, Stator	52	B1899	2	DECAL, Heat Shield
7	65791	1	BEARING	53	B4901	1	DECAL, 1-800-4MyHome
8	96796	1	WASHER, Special M8 Flat	55	25244	12	NUT, Hex 5/16 - 18
9	22129	12	WASHER, M8 Lock	57	B1898	1	DECAL, Control Panel
10	86307	4	HHMS, 5/16 - 24 x 3/4 Lg. Sems	58	B1332A	1	ASSEMBLY, Control Box
11	47481	1	HHCS, 5/16 - 24 x 10 - 5/8 Lg.	60	22531	2	HHCS, 5/16 - 18 x 1-3/4" Lg.
12	92609	2	MOUNT, Vibration	62	93826	1	DECAL, Start Instructions
13	82857	2	MOUNT, Vibration	63	77282	1	SWITCH, Starter
14	40976	2	SCREW, M8 - 1.25 x 20mm	64	22287	2	SCREW, 1/4 - 20" x 3/4"
15	66476	2	CAPSCREW, M6 - 1.0 x 12mm	65	22097	2	WASHER, M6 Lock
16	92532	1	BRACKET, Muffler	66	22127	2	NUT, 1/4 - 20" Hex
17	22142	2	SCREW, 5/16 - 18 x 3/4"	67	77283	1	ASSY, Starter Switch
18	91153	1	MUFFLER	68	96068	1	SHIELD, Heat
19	90239	1	GASKET, Muffler	69	56893	5	CRIMPTITE, 10 - 24 x 1/2
20	81917	1	PIN, 4 mm x 10 Roll	70	B2153	8	HHCS, 12 - 14 x 7/8 Self Driller
21	81887J	1	WRAP, Stator	71	23762	1	SHAKEPROOF, Ext #10
22	52618	2	HHCS, M5 - 0.8 x12 Lg.	72	22097	4	LOCKWASHER, 1/4 - M6
23	52856	2	NUT, M5 Locking	900	NSP	1	ENGINE, 15 HP, Generac Power Systems, EHF 00935
25	66825C	1	CARRIER, Rear Bearing	<b>Parts Not Illustrated</b>			
26	74908	4	TAPTITE, M5 - 0.8 x 10 Lg.	B1901	1	Owner's Manual	
27	66449L	4	BOLT, M6 - 1 x 190 mm Stator	AB3061	2	28oz. Engine Oil	
28	65795	2	RECTIFIER, Battery Charge	37806	1	120V 30A Locking Plug	
29	66849C	1	TAPTITE, M5 - 0.8 x 30 Lg.	43438	1	120/240V 30 A Locking Plug	
30	67022	1	GROMMET, Rubber	65787	1	Battery Charge Cables	
31	84132	1	ASSEMBLY, Power Regulator	84882	1	Spark Plug Wrench/Driver	
32	66386	1	ASSEMBLY, Brush Holder	<b>Optional Accessories Not Illustrated</b>			
33	66849	2	TAPTITE, M5 - 0.8 x 16 Lg.	09-32688		Cord Wrap Kit	
34	78388	1	COVER, Bearing Carrier	09-32687		120V 30A Locking Plug	
35	22769	1	WASHER, Shakeproof Int. #10	<b>Battery Tray Kit Not Illustrated</b>			
36	86494	1	SCREW, M6 - 1.0 x 16 Lg. Wing	96923	1	Battery Tray	
37	86292	1	HHCS, #10 Self Driller	22129	2	Lockwasher	
38	77395	4	NUT, M6 Flange Lock	45771	2	Hex Nut	
39	83465	4	GROMMET, Tank	96925	1	Battery Tie-down	
40	78831B	4	HHMS, M6 - 1.0 x 60 Black	96924	2	J-Bolt	
41	80270	1	VALVE, Tank	154-53621	1	Battery Cable Positive	
42	78299	1	BUSHING, Plastic Tank	155-53621	1	Battery Cable Negative	
43	94834	1	CAP, Fuel Gauge	22145	2	Flat Washer	
44	93595	1	TANK, Fuel				
45	92039	1	SHIELD, Heat				
46	92665	1	INSULATION, #2 -1/4" Thick				

**CRAFTSMAN 7500 Watt AC Generator 580.327181**  
**Control Panel — Exploded View and Parts List**

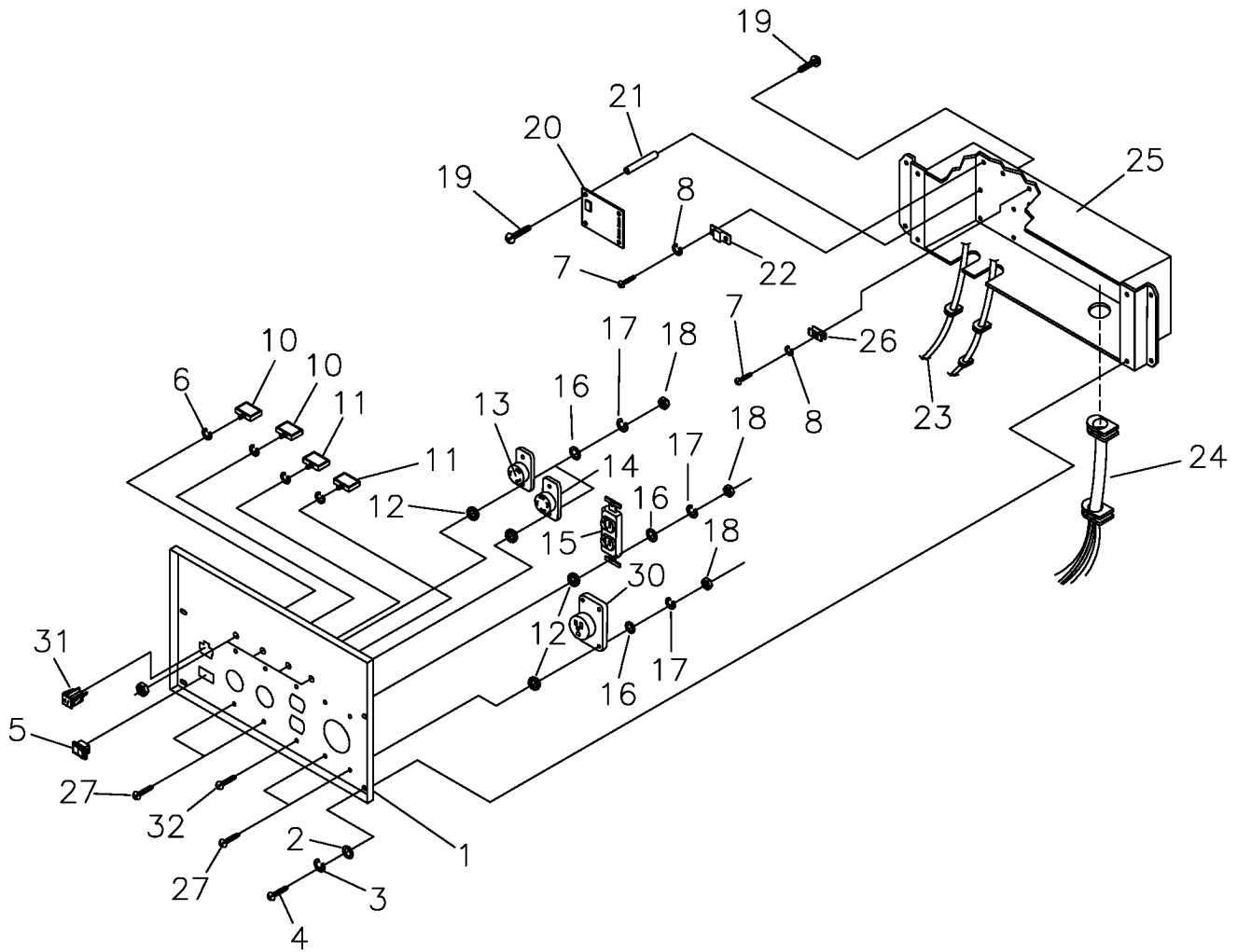

ITEM	PART #	QTY.	DESCRIPTION	ITEM	PART #	QTY.	DESCRIPTION
1	B1331	1	PANEL, Control	17	22264	10	WASHER, #8 M4 Lock
2	23897	4	WASHER, #10 M5 Flat	18	51715	10	NUT, M4 - 0.7 Hex
3	49226	4	WASHER, M5 Lock	19	64526	8	SCREW, #6-32 x 3/8"
4	91526	4	SCREW, M5-0.8 x 12 mm	20	83970	1	BOARD, System Control
5	82538	1	SWITCH, Idle Control	21	64525	4	3/4" Hex Standoff
6	82881	4	WASHER, 7/16" Int. Lock	22	87962	1	CIRCUIT BREAKER, 10A (automatic), 12V
7	43181	4	SCREW, M3 - 0.5 x 10 mm	23	84335	1	ASSEMBLY, Wire Harness
8	43182	4	WASHER, M3 Lock	24	84134	1	GROMMET, Rubber Connector
10	75207A	2	CIRCUIT BREAKER, 30 AMP	25	92069	1	BOX, Control Panel
11	75207	2	CIRCUIT BREAKER, 20 AMP	26	84028	1	TRANSFORMER, Idle Control
12	23365	10	WASHER, #8 Shakeproof	27	75475	9	SCREW, M4 - 0.7 x 10 mm
13	68868	1	OUTLET, 30A, 120V Locking Type	30	74191	1	OUTLET, 50A, 240V
14	43437	1	OUTLET, 30A, 120V/240V Locking Type	31	90418	1	OUTLET, 10A, 12VDC
15	68759	1	OUTLET, 20A, 120V	32	75476	1	PPHMS, M4 - 0.7 x 16
16	43180	10	WASHER, M4 Flat				

**CRAFTSMAN 7500 Watt AC Generator 580.327181**  
**Wheel Kit — Exploded View and Parts List**

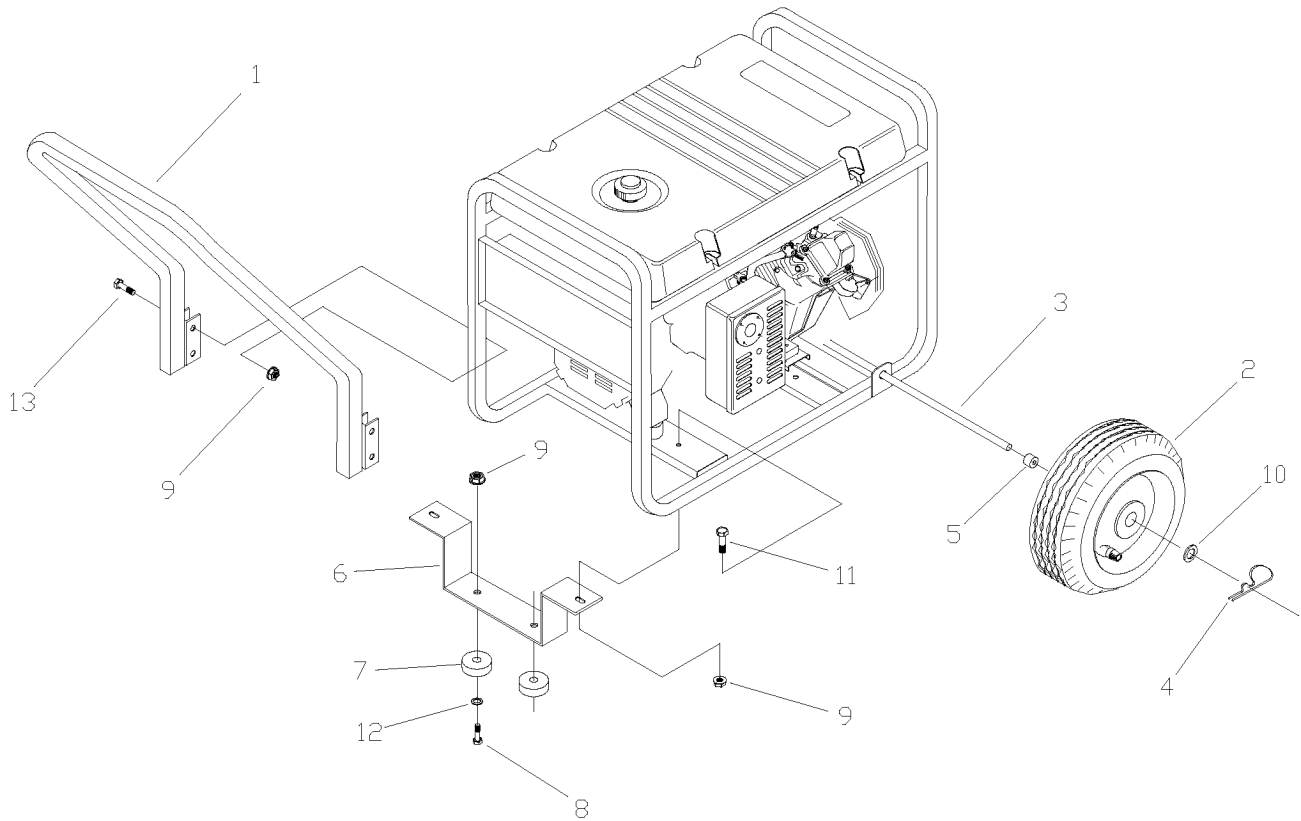

ITEM	PART NO.	QTY.	DESCRIPTION
1	93393A	1	HANDLE
2	89742	2	WHEEL
3	93693A	1	AXLE
4	87005	2	PIN, Retaining
5	89635	2	SPACER, Wheel
6	93696	1	LEG, Support
7	27007	2	MOUNT, Vibration
8	42909	2	CAPSCREW, Hex Hd. M8 - 1.25 x 30 Lg.
9	52858	8	NUT, Lock M8
10	22247	2	WASHER, Wheel
11	39253	2	CAPSCREW, Hex Hd. - M8 - 1.25 x 20 Lg.
12	22145	2	WASHER, Vibration Mtg.
13	39287	4	HHCS, M8 - 1.25 x 45 Lg GR 10.9

**GENERAC Power Systems Engine, Model EHF 00935**  
**Low Oil Shutdown And Governor– Exploded View**

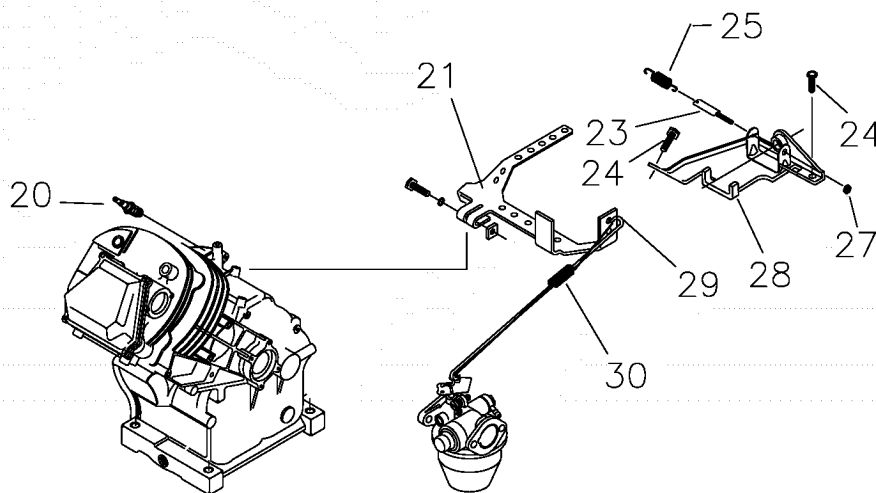
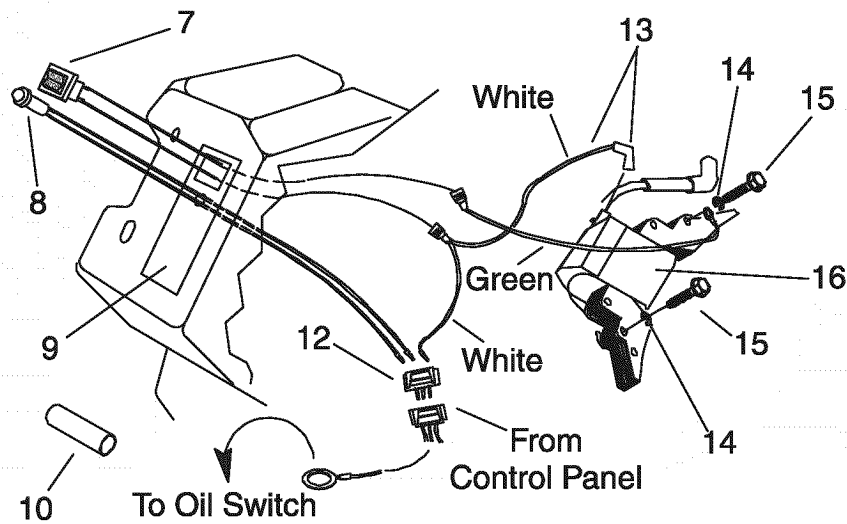

ITEM	PART NO.	QTY.	DESCRIPTION	ITEM	PART NO.	QTY.	DESCRIPTION
7	78653	1	Run/Stop Switch	20	72347	1	Sparkplug
8	85272	1	Led Assembly	21	72734	1	Governor Lever
9	93104	1	L.O.S. Decal	23	83502	1	Adjust Screw
10	93611	1	Black Sleeve	24	83512	2	M8 x 15 Taptite
12	84329	1	3 Pin Male Hsg.	25	73100	1	60Hz Gov. Spring
13	92981	1	Wire Asm.	27	83503	1	M5 Lock Nut
14	22097	2	M6 Lockwasher	28	73101	1	Governor Bracket
15	92079	2	M6 x 30 Taptite	29	72735	1	Governor Rod
16	84542	1	Ignition Coil	30	72789	1	Anti-Lash Spring

**GENERAC Power Systems Engine, Model EHF 00935**  
**Low Oil Shutdown And Governor– Exploded View**

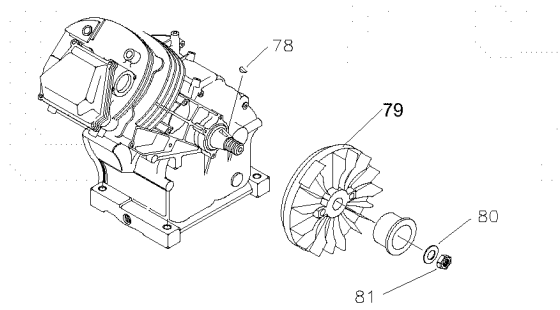

ITEM	PART NO.	QTY.	DESCRIPTION
78	82774	1	Woodruff Key
79	91222C	1	Flywheel w/Ring Gear (410)
80	67198N	1	Conical Washer
81	67890	1	M20 Hex Nut

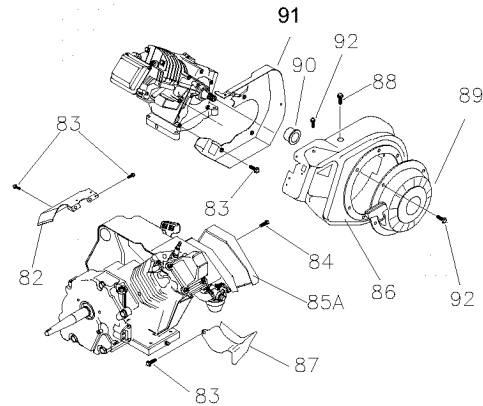

ITEM	PART NO.	QTY.	DESCRIPTION
82	88433	1	Top Wrapper
83	45756	7	M6 x 10 Taptite
84	78609	2	Cover Bolt
85	73104A	1	Air Box Cover
86	92437	1	Blower Housing
87	88434	1	Lower Wrapper
88	66476	4	M6 x 12mm cap screw
89	96195	1	Recoil Assembly
90	96196	1	Recoil Cup
91	73116A	1	Back plate, E. SRT
92	81668	5	M6 x 10 HHCS
93	83512	1	M8 x 15 Taptite

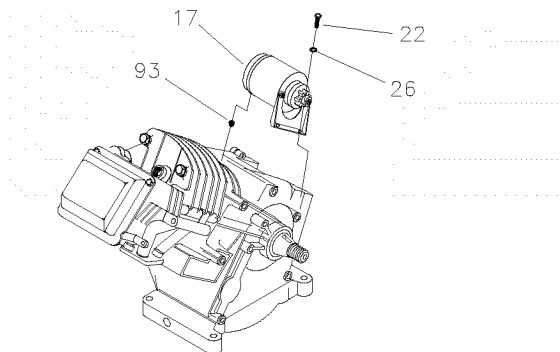

ITEM	PART NO.	QTY.	DESCRIPTION
17	21544	1	Starter Motor
22	40976	2	SHCS M8–1.25 x 20
26	22129	2	Lock Washer M8
93	B2160	1	Rubber Spacer

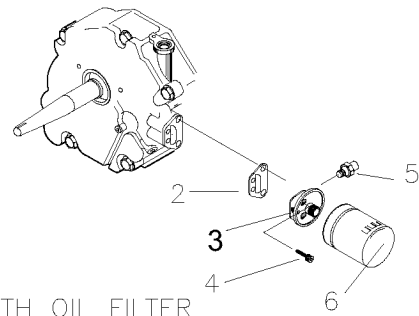

ITEM	PART NO.	QTY.	DESCRIPTION
2	86999	1	Oil Filter Gasket
3	94683	1	Oil Filter Adapter
4	49821	2	M8 x 30 SHCS
5	60108	1	Oil Press Switch
6	70185	1	Oil Filter

**GENERAC Power Systems Engine, Model EHF 00935**  
**Carburetor, Air Cleaner, Oil Switch and Oil Blockoff – Exploded View and Parts List**

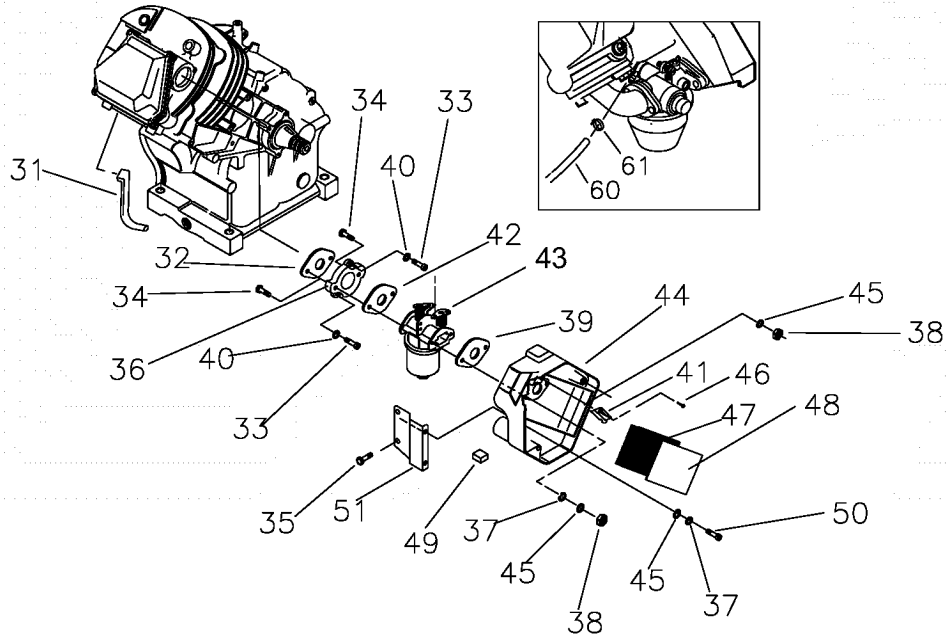

ITEM	PART NO.	QTY.	DESCRIPTION	ITEM	PART NO.	QTY.	DESCRIPTION
31	72745	1	Breather Hose	43	A4600	1	410 Nikki Carb.
32	91039	1	Head/Manifold Gasket	44	73108A	1	Air Cleaner Base
33	40945	2	M6 x 20 SHCS	45	49811	4	M6 Flatwasher
34	81647	2	Carb. Bolt	46	59635	1	#8 x 3/8 Plastite
35	66476	2	M6 x 12 HHCS	47	73111	1	Air Filter
36	91028	1	K Adapter	48	81646	1	Pre-cleaner
37	22097	3	M6 Lock Washer	49	83504	1	Choke Knob
38	49813	2	M6 Hex Nut	50	47411	2	M6 x 16 HHCS
39	90970	1	Carb./Airbox Gasket	51	90827	1	Brkt. Air Box
40	93873	2	M6 Ribbed Lockwasher	60	30340	12"	1/4" ID Hose
41	91204	1	Spitback Plate	61	48031C	1	Hose Clamp
42	89228	1	Carb/Manifold Gasket				



**GENERAC Power Systems Engine, Model EHF 00935**  
**Long Block – Exploded View and Parts List**

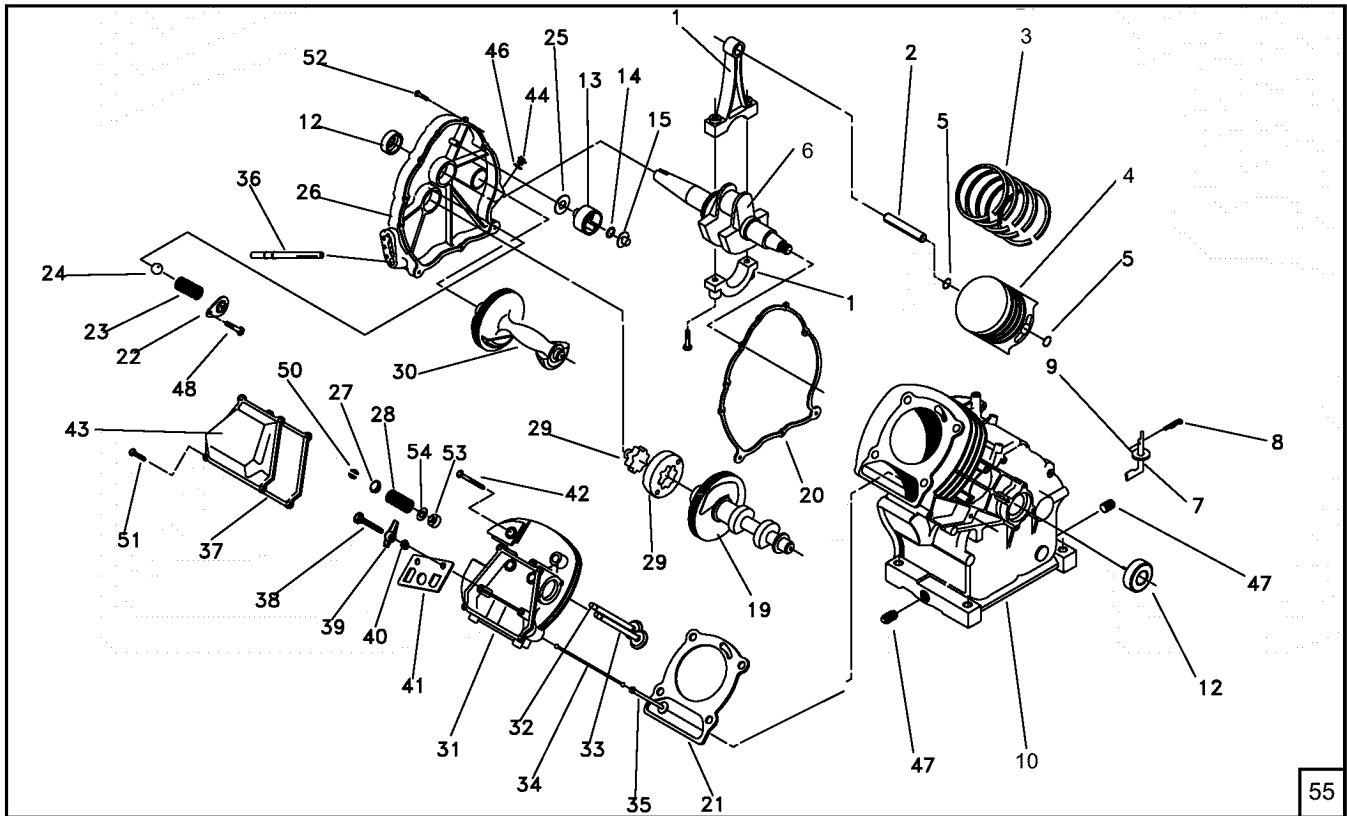

ITEM	DESCRIPTION	PART NO.	QTY.	ITEM	DESCRIPTION	PART NO.	QTY.
1	Connecting Rod with Cap and Bolt	71978	1	30	Balancer	84430	1
2	Piston Pin	71980	1	31	Cylinder Head With Valve Seats & Guides	21714	1
3	Piston Ring Set (410)	21533	1	32	Exhaust Valve	86516	1
4	Piston (410)	96699	1	33	Intake Valve	86517	1
5	Piston Pin Retainer	71983	2	34	Push Rod	88396B	2
6	Crank Shaft Assembly With Gears (Small Taper)	78666A	1	35	Tappet	83897	2
7	Governor Arm	83948	1	36	Oil Pick-Up Assembly	77158	1
8	Governor Arm "R" Pin	78658	1	37	Rocker Cover Gasket	71987	1
9	Governor Arm Washer	78659	2	38	Pivot Ball Stud	72694	2
10	Crankcase H.S. W/Taper Plugs (410)	88261E	1	39	Rocker Arm	83907	2
12	Crankshaft Seal	72655	2	40	Jam Nut (Rocker Arm)	72696	2
13	Gov. Gear Assembly	83912	1	41	Push Rod Guide Plate	78694	1
14	Governor Retainer ("C" Ring)	78645	1	42	M10 x 108 Head Bolt	21742	4
15	Governor Spool	76365	1	43	Rocker Cover Breather Assembly	83938	1
19	Camshaft Assembly	83932	1	44	Oil Fill Plug	76329	1
20	Crankcase Gasket	76701	1	46	O-ring 17.8 I.D. x 2.4 THK.	86254	1
21	Cylinder Head Gasket (410)	21713B	1	47	3/8" NPT Pipe Plug	26925	2
22	Oil Pressure Relief Cover	78691	1	48	M5-0.8 x 8mm Screw (Thread Forming)	74908	1
23	Press. Relief Spring	83918	1	50	Valve Spring Keeper	86515	4
24	Press. Relief Ball	76362	1	51	M6-1 x 12mm Pan Head Screw and Lockwasher	78606	4
25	Thrust Washer	76361	1	52	Hex Head flange Bolt M8 1.25 x 42mm	A1442	8
26	Gear Cover	88260B	1	53	Valve Stem Seal	78672	1
27	Valve Spring Retainer	86514	2	54	Valve Spring Washer	89673	2
28	Valve Spring	91308	2	55	Long Block Assm.	A1044	0
29	Gerotor Set	86025	1				

# EMISSION CONTROL SYSTEM WARRANTY

## CALIFORNIA AND FEDERAL EMISSION CONTROL WARRANTY STATEMENT

### Your Warranty Rights and Obligations

The California Air Resources Board (CARB), United States Environmental Protection Agency (EPA), and Sears Roebuck and Co. USA (Sears) are pleased to explain the emissions control system warranty on your 1997 and later utility and lawn and garden equipment engine. New Utility and Lawn and Garden Equipment (ULGE) engines must be designed, built, and equipped to meet both the State of California and Federal stringent anti-smog standards. Sears must warrant the emission control system on your ULGE engine for the periods of time listed below provided there has been no abuse, neglect, or improper maintenance of your ULGE engine.

The emissions control system may include parts such as the carburetor, ignition and exhaust systems. When a warrantable condition occurs, Sears will repair your lawn and garden equipment engine at no cost to you. Expenses covered under warranty include diagnosis, replacement parts and labor.

### Manufacturer's Warranty Coverage

The 1997 and later ULGE engines are warranted for two years. If any emission related component or system on your engine (as listed below) is found to be defective, repairs or replacement will be performed by an authorized Sears service center.

### Owner's Warranty Responsibilities

As the ULGE engine owner, you are responsible for the completion of all required maintenance as listed in your factory supplied Owner's Manual. For warranty purposes Sears recommends that you retain all receipts covering maintenance on your ULGE engine. However, Sears cannot deny warranty solely because of the lack of receipts or for your failure to ensure the completion of all scheduled maintenance.

As the ULGE engine owner, you should be aware that Sears may deny any and/or all warranty coverage or responsibility if your ULGE engine or a part/component of it has failed due to abuse, neglect, improper maintenance, unapproved modifications, or the use of counterfeit and/or 'grey-market' parts not made, supplied or approved by the original equipment manufacturer.

You are responsible for presenting your ULGE engine to a Sears authorized service center as soon as a problem occurs. Warranty repairs should be completed in a reasonable amount of time, not to exceed 30 days.

If you have any questions regarding your warranty rights and responsibilities, you should contact your nearest authorized service center or call Sears at **1-800-473-7247**.

### Warranty Commencement Date

The warranty period begins on the date the ULGE engine is delivered to the original, end-use purchaser.

### Length of Coverage

Sears warrants to the initial owner and each subsequent purchaser that the engine is free from defects in materials and workmanship which cause the failure of a warranted part for a period of two years.

### What is Covered

#### Repair or Replacement of Parts

Repair or replacement of any warranted part will be performed at no charge to the owner at an approved Sears service center. If you have any questions regarding your warranty rights and responsibilities, you should contact your nearest authorized service center or call Sears at **1-800-473-7247**.

## Warranty Period

Any warranted part which is not scheduled for replacement as required maintenance shall be warranted for 2 years. Any warranted part which is scheduled only for regular inspection and/or has instructions to the effect of "repair or replace as necessary" shall also be warranted for 2 years. Any warranted part which is scheduled for replacement as required maintenance shall be warranted either for the period of time up to its first scheduled replacement, or for 2 years, whichever comes sooner.

## Diagnosis

When the ULGE engine is inspected by an authorized Sears service center, the owner shall not be held responsible for diagnostic costs if the repair is deemed warrantable.

## Consequential Damages

Sears may be liable for damages to other engine components caused by the failure of a warranted part if the failed part was still under warranty.

## What is not covered

### Owner Responsibilities

Any failures caused by abuse, neglect, or improper maintenance will not be covered.

### Add-On or Modified Parts

The use of add-on, unauthorized or modified parts constitutes sufficient reason for denial of submitted warranty repairs. Sears will not be held liable for repairs of this type.

## How to File a Claim

If you have any questions regarding your warranty rights and responsibilities, you should contact your nearest authorized service center or call Sears at **1-800-473-7247**.

## Where to get Warranty Service

Warranty services or repairs shall be provided at all Sears authorized service centers.

## Maintenance, Replacement and Repair of Emission Related Parts

Any Sears approved replacement part used in the performance of any warranty maintenance or repair on emission related parts will be provided without charge to the owner if the part is under warranty.

## Emission Control Warranty Parts List

1. Fuel Metering System:
  - a. Carburetor assembly
  - b. Fuel filter
2. Air Induction System:
  - a. Intake manifold
  - b. Air cleaner
3. Catalytic Muffler Assembly (if so equipped), including:
  - a. Muffler gasket
  - b. Exhaust manifold
4. Ignition System
  - a. Spark plug
  - b. Ignition module
5. Crankcase Breather Tube

**For in-home major brand repair service:**

Call 24 hours a day, 7 days a week

**1-800-4-MY-HOME<sup>SM</sup>** (1-800-469-4663)

**Para pedir servicio de reparación a domicilio – 1-800-676-5811**

In Canada for all your service and parts needs call – **1-800-665-4455**  
Au Canada pour tout le service ou les pièces

**For the repair or replacement parts you need:**

Call 7 am – 7 pm, 7 days a week

**1-800-366-PART** (1-800-366-7278)

**Para ordenar piezas con entrega a domicilio – 1-800-659-7084**

**For the location of a Sears Parts and Repair Center in your area:**

Call 24 hours a day, 7 days a week

**1-800-488-1222**

**For information on purchasing a Sears Maintenance Agreement  
or to inquire about an existing Agreement:**

Call 9 am – 5 pm, Monday – Saturday

**1-800-827-6655**



The Service Side of Sears<sup>SM</sup>