

12" Dual-Bevel Compound Miter Saw (Model 36-412)



PART NO. A05726 - 10-21-04
Copyright © 2004 Delta Machinery



To learn more about DELTA MACHINERY
visit our website at: www.deltamachinery.com.

For Parts, Service, Warranty or other Assistance,

please call **1-800-223-7278** (In Canada call **1-800-463-3582**).

ESPAÑOL: PÁGINA 23

TABLE OF CONTENTS

IMPORTANT SAFETY INSTRUCTIONS2
SAFETY GUIDELINES3
GENERAL SAFETY RULES4
ADDITIONAL SPECIFIC SAFETY RULES5
FUNCTIONAL DESCRIPTION7
CARTON CONTENTS7
ASSEMBLY8
OPERATIONS10
TROUBLESHOOTING19
MAINTENANCE19
SERVICE21
ACCESSORIES21
WARRANTY22
ESPAÑOL23
SERVICE CENTER LOCATIONSback cover

IMPORTANT SAFETY INSTRUCTIONS

▲ WARNING Read and understand all warnings and operating instructions before using any tool or equipment. When using tools or equipment, basic safety precautions should always be followed to reduce the risk of personal injury. Improper operation, maintenance or modification of tools or equipment could result in serious injury and property damage. There are certain applications for which tools and equipment are designed. Delta Machinery strongly recommends that this product NOT be modified and/or used for any application other than for which it was designed.

If you have any questions relative to its application DO NOT use the product until you have written Delta Machinery and we have advised you.

Online contact form at www.deltamachinery.com

Postal Mail: Technical Service Manager
Delta Machinery
4825 Highway 45 North
Jackson, TN 38305

Information regarding the safe and proper operation of this tool is available from the following sources:

Power Tool Institute
1300 Sumner Avenue, Cleveland, OH 44115-2851
www.powertoolinstitute.org

National Safety Council
1121 Spring Lake Drive, Itasca, IL 60143-3201

American National Standards Institute, 25 West 43rd Street, 4 floor, New York, NY 10036 www.ansi.org
ANSI 01.1 Safety Requirements for Woodworking Machines, and

the U.S. Department of Labor regulations www.osha.gov

SAVE THESE INSTRUCTIONS!

SAFETY GUIDELINES - DEFINITIONS

It is important for you to read and understand this manual. The information it contains relates to protecting YOUR SAFETY and PREVENTING PROBLEMS. The symbols below are used to help you recognize this information.

- ▲ DANGER** Indicates an imminently hazardous situation which, if not avoided, will result in death or serious injury.
- ▲ WARNING** Indicates a potentially hazardous situation which, if not avoided, could result in death or serious injury.
- ▲ CAUTION** Indicates a potentially hazardous situation which, if not avoided, may result in minor or moderate injury.
- CAUTION** Used without the safety alert symbol indicates potentially hazardous situation which, if not avoided, may result in property damage.

CALIFORNIA PROPOSITION 65

▲ WARNING **SOME DUST CREATED BY POWER SANDING, SAWING, GRINDING, DRILLING, AND OTHER CONSTRUCTION ACTIVITIES** contains chemicals known to cause cancer, birth defects or other reproductive harm.

Some examples of these chemicals are:

- lead from lead-based paints,
- crystalline silica from bricks and cement and other masonry products, and
- arsenic and chromium from chemically-treated lumber.

Your risk from these exposures varies, depending on how often you do this type of work. To reduce your exposure to these chemicals: work in a well ventilated area, and work with approved safety equipment, always wear **MSHA/NIOSH** approved, properly fitting face mask or respirator when using such tools.

GENERAL SAFETY RULES

▲ WARNING FAILURE TO FOLLOW THESE RULES MAY RESULT IN SERIOUS INJURY.

- FOR YOUR OWN SAFETY, READ THE INSTRUCTION MANUAL BEFORE OPERATING THE MACHINE.** Learning the machine's application, limitations, and specific hazards will greatly minimize the possibility of accidents and injury.
- USE CERTIFIED SAFETY EQUIPMENT.** Eye protection equipment should comply with ANSI Z87.1 standards, hearing equipment should comply with ANSI S3.19 standards, and dust mask protection should comply with MSHA/NIOSH certified respirator standards. Splinters, air-borne debris, and dust can cause irritation, injury, and/or illness.
- DRESS PROPERLY.** Do not wear tie, gloves, or loose clothing. Remove watch, rings, and other jewelry. Roll up your sleeves. Clothing or jewelry caught in moving parts can cause injury.
- DO NOT USE THE MACHINE IN A DANGEROUS ENVIRONMENT.** The use of power tools in damp or wet locations or in rain can cause shock or electrocution. Keep your work area well-lit to prevent tripping or placing arms, hands, and fingers in danger.
- MAINTAIN ALL TOOLS AND MACHINES IN PEAK CONDITION.** Keep tools sharp and clean for best and safest performance. Follow instructions for lubricating and changing accessories. Poorly maintained tools and machines can further damage the tool or machine and/or cause injury.
- CHECK FOR DAMAGED PARTS.** Before using the machine, check for any damaged parts. Check for alignment of moving parts, binding of moving parts, breakage of parts, and any other conditions that may affect its operation. A guard or any other part that is damaged **should be properly repaired or replaced.** Damaged parts can cause further damage to the machine and/or injury.
- KEEP THE WORK AREA CLEAN.** Cluttered areas and benches invite accidents.
- KEEP CHILDREN AND VISITORS AWAY.** Your shop is a potentially dangerous environment. Children and visitors can be injured.
- REDUCE THE RISK OF UNINTENTIONAL STARTING.** Make sure that the switch is in the "OFF" position before plugging in the power cord. In the event of a power failure, move the switch to the "OFF" position. An accidental start-up can cause injury.
- USE THE GUARDS.** Check to see that all guards are in place, secured, and working correctly to prevent injury.
- REMOVE ADJUSTING KEYS AND WRENCHES BEFORE STARTING THE MACHINE.** Tools, scrap pieces, and other debris can be thrown at high speed, causing injury.
- USE THE RIGHT MACHINE.** Don't force a machine or an attachment to do a job for which it was not designed. Damage to the machine and/or injury may result.
- USE RECOMMENDED ACCESSORIES.** The use of accessories and attachments not recommended by Delta may cause damage to the machine or injury to the user.
- USE THE PROPER EXTENSION CORD.** Make sure your extension cord is in good condition. When using an extension cord, be sure to use one heavy enough to carry the current your product will draw. An undersized cord will cause a drop in line voltage, resulting in loss of power and overheating. See the Extension Cord Chart for the correct size depending on the cord length and nameplate ampere rating. If in doubt, use the next heavier gauge. The smaller the gauge number, the heavier the cord.
- SECURE THE WORKPIECE.** Use clamps or a vise to hold the workpiece when practical. Loss of control of a workpiece can cause injury.
- FEED THE WORKPIECE AGAINST THE DIRECTION OF THE ROTATION OF THE BLADE, CUTTER, OR ABRASIVE SURFACE.** Feeding it from the other direction will cause the workpiece to be thrown out at high speed.
- DON'T FORCE THE WORKPIECE ON THE MACHINE.** Damage to the machine and/or injury may result.
- DON'T OVERREACH.** Loss of balance can make you fall into a working machine, causing injury.
- NEVER STAND ON THE MACHINE.** Injury could occur if the tool tips, or if you accidentally contact the cutting tool.
- NEVER LEAVE THE MACHINE RUNNING UNATTENDED. TURN THE POWER OFF.** Don't leave the machine until it comes to a complete stop. A child or visitor could be injured.
- TURN THE MACHINE "OFF", AND DISCONNECT THE MACHINE FROM THE POWER SOURCE** before installing or removing accessories, before adjusting or changing set-ups, or when making repairs. An accidental start-up can cause injury.
- MAKE YOUR WORKSHOP CHILDPROOF WITH PADLOCKS, MASTER SWITCHES, OR BY REMOVING STARTER KEYS.** The accidental start-up of a machine by a child or visitor could cause injury.
- STAY ALERT, WATCH WHAT YOU ARE DOING, AND USE COMMON SENSE. DO NOT USE THE MACHINE WHEN YOU ARE TIRED OR UNDER THE INFLUENCE OF DRUGS, ALCOHOL, OR MEDICATION.** A moment of inattention while operating power tools may result in injury.
- THE DUST GENERATED** by certain woods and wood products can be injurious to your health. Always operate machinery in well-ventilated areas, and provide for proper dust removal. Use wood dust collection systems whenever possible.

ADDITIONAL SAFETY RULES FOR MITER SAWS

▲ WARNING

FAILURE TO FOLLOW THESE RULES MAY RESULT IN SERIOUS INJURY.

1. **DO NOT OPERATE THIS MACHINE** until it is completely assembled and installed according to the instructions. A machine incorrectly assembled can cause serious injury.
2. **OBTAIN ADVICE** from your supervisor, instructor, or another qualified person if you are not thoroughly familiar with the operation of this machine. Knowledge is safety.
3. **FOLLOW ALL WIRING CODES** and recommended electrical connections to prevent shock or electrocution.
4. **SECURE THE MACHINE TO A SUPPORTING SURFACE.** Vibration can possibly cause the machine to slide, walk, or tip over, causing serious injury.
5. **USE ONLY CROSSCUT SAW BLADES.** Use only zero-degree or negative hook angles when using carbide-tipped blades. Do not use blades with deep gullets. These can deflect and contact the guard, and can cause damage to the machine and/or serious injury.
6. **USE ONLY BLADES OF THE CORRECT SIZE AND TYPE** specified for this tool to prevent damage to the machine and/or serious injury.
7. **USE A SHARP BLADE.** Check the blade to see if it runs true and is free from vibration. A dull blade or a vibrating blade can cause damage to the machine and/or serious injury.
8. **INSPECT BLADE FOR CRACKS** or other damage prior to operation. A cracked or damaged blade can come apart and pieces can be thrown at high speeds, causing serious injury. Replace cracked or damaged blades immediately.
9. **CLEAN THE BLADE AND BLADE FLANGES** prior to operation. Cleaning the blade and flanges allows you to check for any damage to the blade or flanges. A cracked or damaged blade or flange can come apart and pieces can be thrown at high speeds, causing serious injury.
10. **USE ONLY BLADE FLANGES** specified for this tool to prevent damage to the machine and/or serious injury.
11. **CLEAR THE AREA OF FLAMMABLE LIQUIDS** and/or gas prior to operation. Sparks can occur that would ignite the liquids and cause a fire or an explosion.
12. **CLEAN THE MOTOR AIR SLOTS** of chips and sawdust. Clogged motor air slots can cause the machine to overheat, damaging the machine and possibly causing a short which could cause serious injury.
13. **TIGHTEN THE TABLE CLAMP HANDLE** and any other clamps prior to operation. Loose clamps can cause parts or the workpiece to be thrown at high speeds.
14. **NEVER START THE TOOL** with the blade against the workpiece. The workpiece can be thrown, causing serious injury.
15. **KEEP ARMS, HANDS, AND FINGERS** away from the blade to prevent severe cuts. Clamp all workpieces that would cause your hand to be in the "Table Hazard Zone" (within the red lines).
16. **WHEN CUTTING WITH A COMPOUND SLIDING MITER SAW, PUSH THE SAW FORWARD (AWAY FROM YOU)** and toward the fence. Pulling the saw toward you can cause the saw to kick upward and toward you.
17. **WHEN USING A SLIDING MITER SAW AS A REGULAR MITER SAW, LOCK THE SLIDE MECHANISM IN PLACE.** If the slide mechanism is not locked, the saw can kick back toward you.
18. **ALLOW THE MOTOR TO COME TO FULL SPEED** prior to starting cut. Starting the cut too soon can cause damage to the machine or blade and/or serious injury.
19. **NEVER REACH AROUND** or behind the saw blade. A moving blade can cause serious injury.
20. **NEVER CUT FERROUS METALS** or masonry. Either of these can cause the carbide tips to fly off the blade at high speeds causing serious injury.
21. **NEVER CUT SMALL PIECES.** Cutting small pieces can cause your hand to move into the blade, resulting in serious injury.
22. **NEVER LOCK THE SWITCH** in the "ON" position. Setting up the next cut could cause your hand to move into the blade, resulting in severe injury.
23. **NEVER APPLY LUBRICANT** to a running blade. Applying lubricant could cause your hand to move into the blade, resulting in serious injury.
24. **DO NOT PERFORM FREE-HAND OPERATIONS.** Hold the work firmly against the fence and table. Free-hand operations on a miter saw could cause the workpiece to be thrown at high speeds, causing serious injury. Use clamps to hold the work when possible.
25. **PROPERLY SUPPORT LONG OR WIDE WORKPIECES.** Loss of control of the workpiece can cause serious injury.
26. **AFTER COMPLETING CUT,** release power switch and wait for coasting blade to come to a complete stop before returning saw to raised position. A moving blade can cause serious injury.
27. **TURN OFF THE MACHINE** and allow the blade to come to a complete stop prior to cleaning the blade area or removing debris in the path of the blade. A moving blade can cause serious injury.
28. **TURN OFF MACHINE** and allow the blade to come to a complete stop before removing or securing workpiece, changing workpiece angle, or changing the angle of the blade. A moving blade can cause serious injury.
29. **PROPERLY SUPPORT LONG OR WIDE WORKPIECES.** Loss of control of the workpiece can cause injury.
30. **NEVER PERFORM LAYOUT, ASSEMBLY, OR SET-UP WORK** on the table/work area when the machine is running. A sudden slip could cause a hand to move into the blade. Severe injury can result.
31. **TURN THE MACHINE "OFF"**, disconnect the machine from the power source, and clean the table/work area before leaving the machine. **LOCK THE SWITCH IN THE "OFF" POSITION** to prevent unauthorized use. Someone else might accidentally start the machine and cause injury to themselves.
32. **BEFORE OPERATING THE SAW,** check and securely lock the bevel, miter, and sliding fence adjustments.
33. **ADDITIONAL INFORMATION** regarding the safe and proper operation of power tools (i.e. a safety video) is available from the Power Tool Institute, 1300 Sumner Avenue, Cleveland, OH 44115-2851 (www.powertoolinstitute.com). Information is also available from the National Safety Council, 1121 Spring Lake Drive, Itasca, IL 60143-3201. Please refer to the American National Standards Institute ANSI O1.1 Safety Requirements for Woodworking Machines and the U.S. Department of Labor regulations.

SAVE THESE INSTRUCTIONS.

Refer to them often
and use them to instruct others.

POWER CONNECTIONS

A separate electrical circuit should be used for your machines. This circuit should not be less than #12 wire and should be protected with a 20 Amp time lag fuse. If an extension cord is used, use only 3-wire extension cords which have 3-prong grounding type plugs and matching receptacle which will accept the machine's plug. Before connecting the machine to the power line, make sure the switch (s) is in the "OFF" position and be sure that the electric current is of the same characteristics as indicated on the machine. All line connections should make good contact. Running on low voltage will damage the machine.

▲ DANGER DO NOT EXPOSE THE MACHINE TO RAIN OR OPERATE THE MACHINE IN DAMP LOCATIONS.

MOTOR SPECIFICATIONS

Your machine is wired for 120 volts, 60 HZ alternating current. Before connecting the machine to the power source, make sure the switch is in the "OFF" position.

GROUNDING INSTRUCTIONS

▲ DANGER THIS MACHINE MUST BE GROUNDED WHILE IN USE TO PROTECT THE OPERATOR FROM ELECTRIC SHOCK.

1. All grounded, cord-connected machines:

In the event of a malfunction or breakdown, grounding provides a path of least resistance for electric current to reduce the risk of electric shock. This machine is equipped with an electric cord having an equipment-grounding conductor and a grounding plug. The plug must be plugged into a matching outlet that is properly installed and grounded in accordance with all local codes and ordinances.

Do not modify the plug provided - if it will not fit the outlet, have the proper outlet installed by a qualified electrician.

Improper connection of the equipment-grounding conductor can result in risk of electric shock. The conductor with insulation having an outer surface that is green with or without yellow stripes is the equipment-grounding conductor. If repair or replacement of the electric cord or plug is necessary, do not connect the equipment-grounding conductor to a live terminal.

Check with a qualified electrician or service personnel if the grounding instructions are not completely understood, or if in doubt as to whether the machine is properly grounded.

Use only 3-wire extension cords that have 3-prong grounding type plugs and matching 3-conductor receptacles that accept the machine's plug, as shown in Fig. A.

Repair or replace damaged or worn cord immediately.

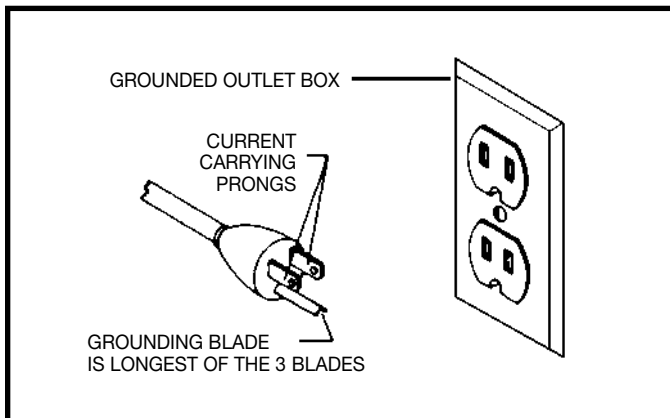

Fig. A

2. Grounded, cord-connected machines intended for use on a supply circuit having a nominal rating less than 150 volts:

If the machine is intended for use on a circuit that has an outlet that looks like the one illustrated in Fig. A, the machine will have a grounding plug that looks like the plug illustrated in Fig. A. A temporary adapter, which looks like the adapter illustrated in Fig. B, may be used to connect this plug to a matching 2-conductor receptacle as shown in Fig. B if a properly grounded outlet is not available. The temporary adapter should be used only until a properly grounded outlet can be installed by a qualified electrician. The green-colored rigid ear, lug, and the like, extending from the adapter must be connected to a permanent ground such as a properly grounded outlet box. Whenever the adapter is used, it must be held in place with a metal screw.

NOTE: In Canada, the use of a temporary adapter is not permitted by the Canadian Electric Code.

▲ DANGER IN ALL CASES, MAKE CERTAIN THE RECEPTACLE IN QUESTION IS PROPERLY GROUNDED. IF YOU ARE NOT SURE HAVE A QUALIFIED ELECTRICIAN CHECK THE RECEPTACLE.

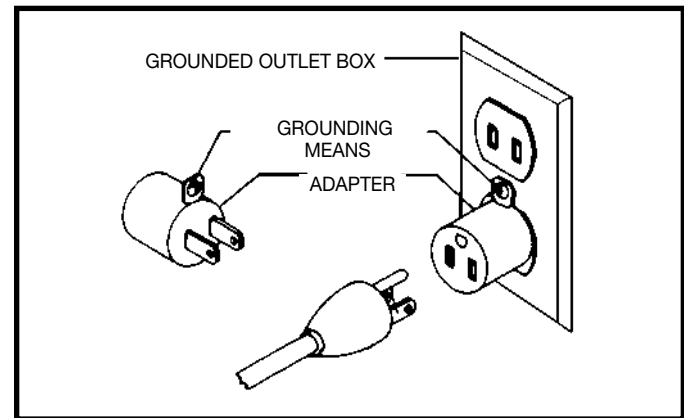

Fig. B

EXTENSION CORDS

⚠ WARNING Use proper extension cords. Make sure your extension cord is in good condition and is a 3-wire extension cord which has a 3-prong grounding type plug and matching receptacle which will accept the machine's plug. When using an extension cord, be sure to use one heavy enough to carry the current of the machine. An undersized cord will cause a drop in line voltage, resulting in loss of power and overheating. Fig. D-1 or D-2, shows the correct gauge to use depending on the cord length. If in doubt, use the next heavier gauge. The smaller the gauge number, the heavier the cord.

MINIMUM GAUGE EXTENSION CORD			
RECOMMENDED SIZES FOR USE WITH STATIONARY ELECTRIC MACHINES			
Ampere Rating	Volts	Total Length of Cord in Feet	Gauge of Extension Cord
0-6	120	up to 25	18 AWG
0-6	120	25-50	16 AWG
0-6	120	50-100	16 AWG
0-6	120	100-150	14 AWG
6-10	120	up to 25	18 AWG
6-10	120	25-50	16 AWG
6-10	120	50-100	14 AWG
6-10	120	100-150	12 AWG
10-12	120	up to 25	16 AWG
10-12	120	25-50	16 AWG
10-12	120	50-100	14 AWG
10-12	120	100-150	12 AWG
12-16	120	up to 25	14 AWG
12-16	120	25-50	12 AWG
12-16	120	GREATER THAN 50 FEET NOT RECOMMENDED	

Fig. D-1

FUNCTIONAL DESCRIPTION

FOREWORD

Delta Model 36-412 is a high capacity 12" dual-bevel compound miter saw designed to cut wood and non-ferrous metals. This machine is supplied with new design features that increase the cutting capacity, including built-in stops to make cutting crown moulding easier. This machine can crosscut 2"x10" workpieces, miter 2"x6" workpieces at 45° both left and right, bevel 2"x10" workpieces left at 45°, and bevel 1"x10" workpieces and 2"x8" workpieces right at 45°. It has positive miter stops at 0°, 15°, 22.5°, 31.6°, and 45° both left and right, and bevel stops at 0°, 33.9° and 45°, both left and right.

NOTICE: THE PHOTO ON THE MANUAL COVER ILLUSTRATES THE CURRENT PRODUCTION MODEL. ALL OTHER ILLUSTRATIONS CONTAINED IN THE MANUAL ARE REPRESENTATIVE ONLY AND MAY NOT DEPICT THE ACTUAL COLOR, LABELING OR ACCESSORIES AND ARE INTENDED TO ILLUSTRATE TECHNIQUE ONLY.

CARTON CONTENTS

- 1 - Miter Saw
- 2 - Dust bag
- 3 - Dust Spout
- 4 - Dust Shroud
- 5 - 1/2" Arbor wrench
- 6 - M4 Pan Head Screw (3)
- 7 - 2mm hex wrench
- 8 - Open end 7/16" wrench

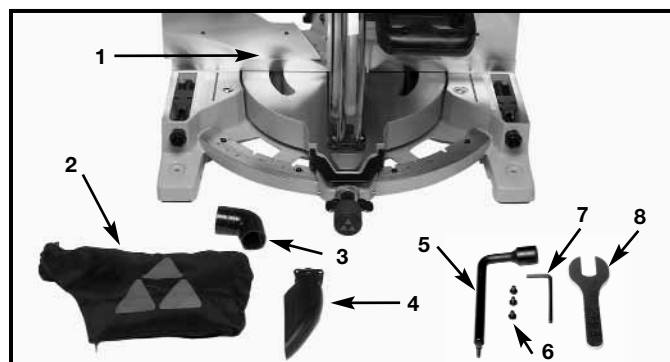

Fig. 2

UNPACKING AND CLEANING

Carefully unpack the machine and all loose items from the shipping container(s). Remove the protective coating from all unpainted surfaces. This coating may be removed with a soft cloth moistened with kerosene (do not use acetone, gasoline or lacquer thinner for this purpose). After cleaning, cover the unpainted surfaces with a good quality household floor paste wax.

⚠ WARNING DO NOT OPERATE THIS MACHINE UNTIL YOU READ AND UNDERSTAND THE ENTIRE INSTRUCTION MANUAL.

1. Carefully remove the machine from the carton. Retain all packing materials until you have inspected and satisfactorily operated the machine.
2. Place the machine on a firm, level surface with proper support of the workpiece.
3. The **36-412** is shipped with the cuttinghead beveled right to 45° and locked in the down position, and the table rotated 45° left. To release the head and move it to the operating position, see **“MOVING CUTTINGHEAD TO THE UP POSITION”** and **“MOVING THE TABLE TO THE 0° CUT-OFF POSITION”** sections in this manual.

ASSEMBLY

ASSEMBLY TOOLS REQUIRED

- * 2mm hex wrench (supplied)
- * 1/2" arbor wrench (supplied)

ASSEMBLY TIME ESTIMATE - 30 minutes

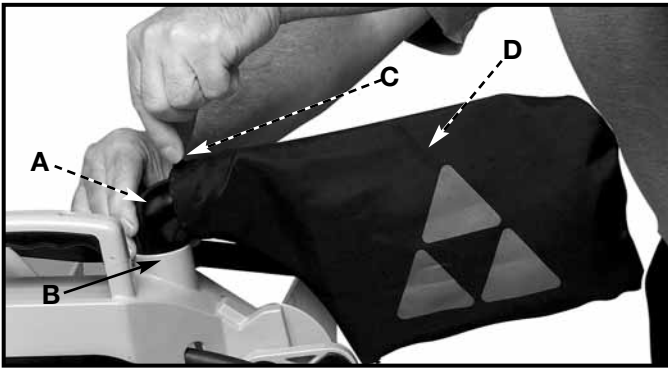

Fig. 3

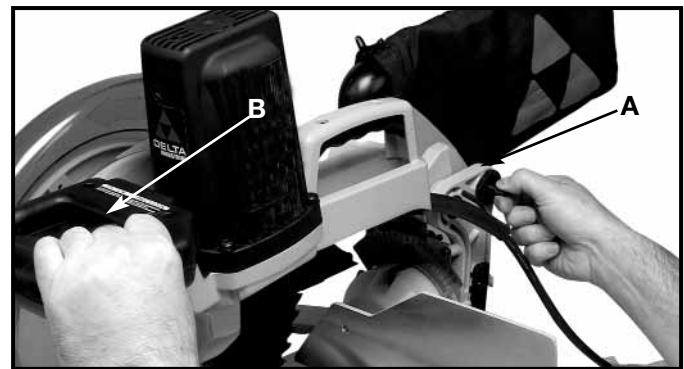

Fig. 3A

ATTACHING DUST BAG

1. Attach dust spout (A) Fig. 3 into port (B).
2. Depress spring clips (C) Fig. 3 of dust bag (D) and clip dust bag (D) over rib of dust spout (A).

MOVING CUTTINGHEAD TO THE UP POSITION

Push down on the handle (B) Fig. 3A, pull out cuttinghead lockpin and move the cuttinghead (B) to the up position (Fig. 4).



Fig. 4A



Fig. 4

ATTACHING DUST SHROUD

⚠ WARNING DISCONNECT THE MACHINE FROM THE POWER SOURCE.

With the cuttinghead in the up position, attach the dust shroud (A) Fig. 4A to the port (B) with three screws using the supplied wrench.

NOTE: Installation is easier if you place a screw on the wrench and then place it in the hole.

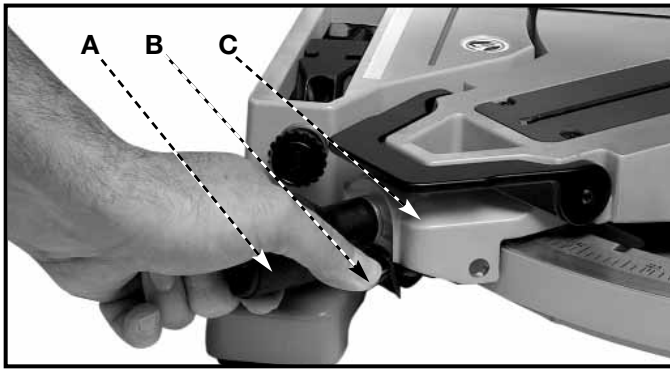

Fig. 5

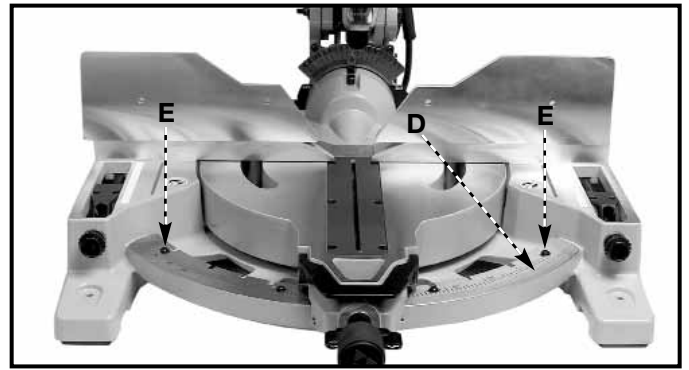

Fig. 6

MOVING TABLE TO THE 0° CUT-OFF POSITION

1. Rotate the locking knob (A) Fig. 5 counter-clockwise as far as it will go. Depress the lever (B) and rotate the table (C) to the 0° straight cut-off position, release the lever (B), and tighten the locking knob (A).
NOTE: This saw incorporates a new slotted plate design feature (D) Fig. 6 with location adjustment screws (E) for fine-adjusting the cutting angle.
2. For proper operation and adjustment of the table, refer to sections, “**ROTATING TABLE FOR MITER CUTTING**”, and “**ADJUSTING SLIDING FIT BETWEEN MOVABLE TABLE AND BASE.**”

FENCE OPERATION

The saw is supplied with left and right fence segments (A) Fig. 7 that incorporate a squeeze clamp feature. To operate the fence segment(s) or to slide to another location, squeeze the clamp (B) Fig. 7A & 8A to disengage the lock. Slide the fence to desired location and release to lock the fence. To remove either fence, depress lever (C) and slide it off the fence base. **NOTE:** The sliding fence segments can be reversed left to right for minimal clearance cutting.

⚠ WARNING MAKE SURE THAT THE FENCES ARE CLEAR OF THE GUARD AND BLADE BEFORE USING SAW.

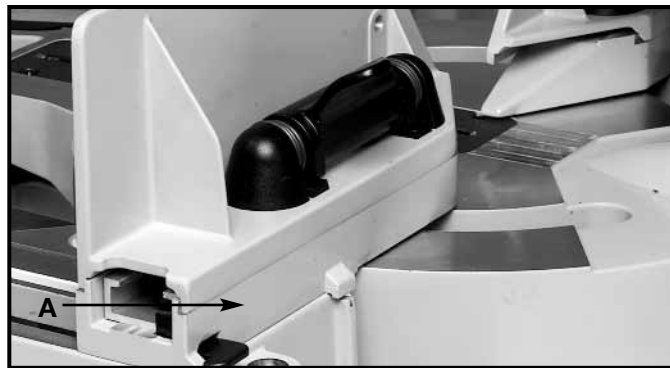

Fig. 7

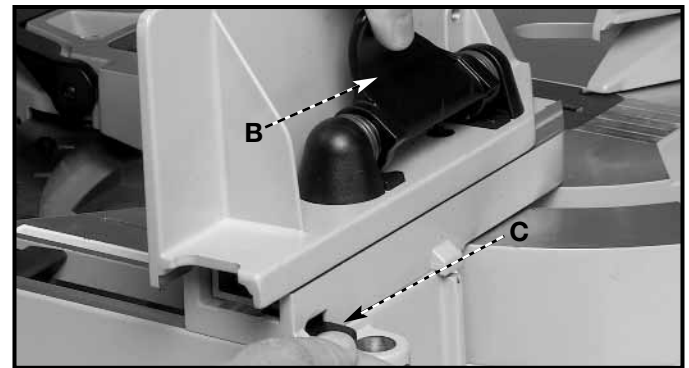

Fig. 7A

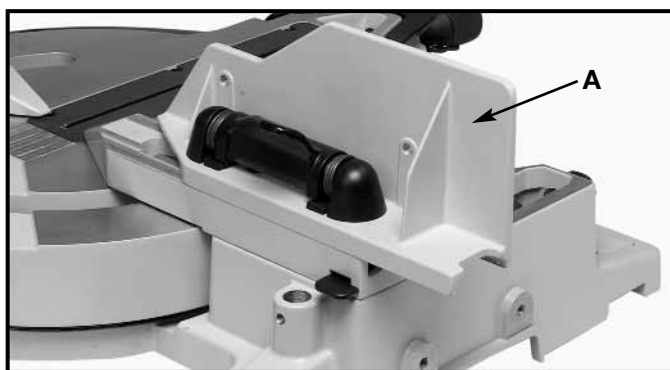

Fig. 8

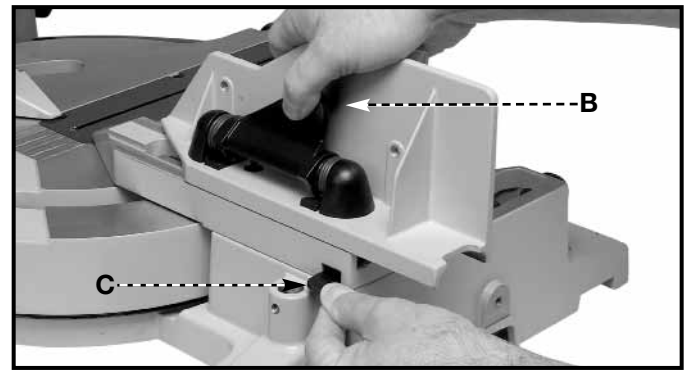

Fig. 8A

FASTENING MACHINE TO SUPPORTING SURFACE

Before operating your compound miter saw, firmly mount it to a workbench or other supporting surface. Four holes (A) Fig. 9 are provided for fastening the saw to a supporting surface.

When frequently moving the saw from place to place, mount the saw to a 3/4" piece of plywood. The saw can then be easily moved from place to place and the plywood can be clamped to the supporting surface using "C" clamps.

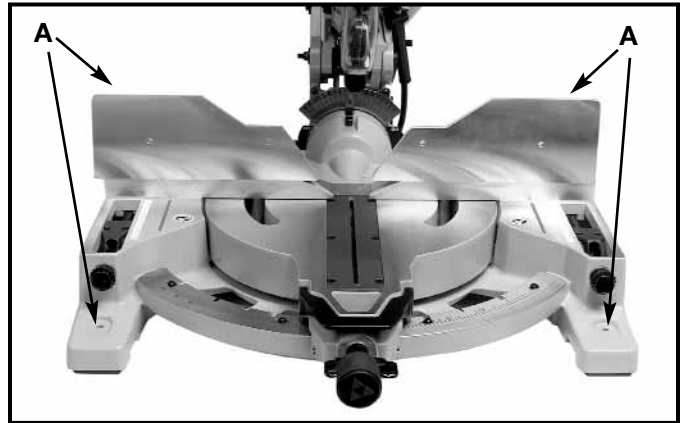

Fig. 9

OPERATIONS

OPERATIONAL CONTROLS AND ADJUSTMENTS

STARTING AND STOPPING MACHINE

To start the machine, depress switch trigger (A) Fig. 11. To stop the machine, release the switch trigger.

This saw is equipped with an automatic electric blade brake. As soon as the switch trigger (A) Fig. 11 is released, the electric brake is activated and stops the blade.

⚠ WARNING A TURNING SAW BLADE CAN BE DANGEROUS. AFTER COMPLETING THE CUT, RELEASE THE SWITCH TRIGGER (A) FIG. 11 TO ACTIVATE BLADE BRAKE. KEEP CUTTINGHEAD DOWN UNTIL THE BLADE HAS COME TO A COMPLETE STOP.

⚠ WARNING THE TORQUE DEVELOPED DURING BRAKING MAY LOOSEN THE ARBOR SCREW. THE ARBOR SCREW SHOULD BE CHECKED PERIODICALLY AND TIGHTENED IF NECESSARY.

LOCKING SWITCH IN THE "OFF" POSITION

⚠ WARNING WHEN THE MITER SAW IS NOT IN USE, THE SWITCH SHOULD BE LOCKED IN THE "OFF" POSITION USING A PADLOCK (B) FIG. 12, WITH A 3/16" DIAMETER SHACKLE TO PREVENT UNAUTHORIZED USE OF THE SAW.

⚠ WARNING IN THE EVENT OF A POWER OUTAGE, ALWAYS LOCK SWITCH IN "OFF" POSITION UNTIL THE MAIN POWER IS RESTORED.

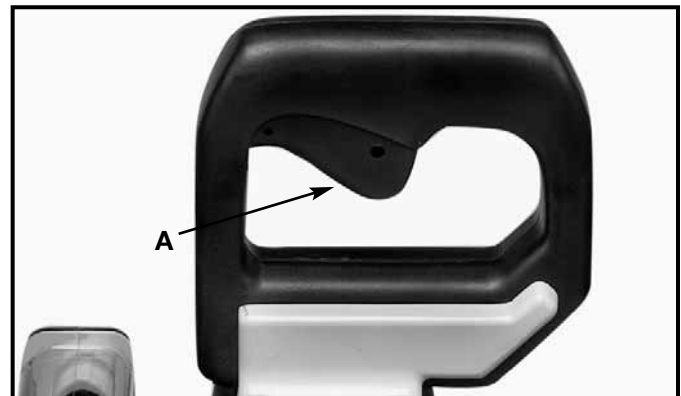

Fig. 11

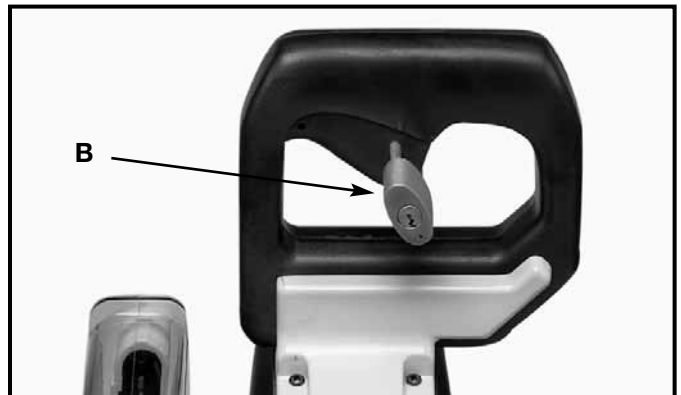

Fig. 12

ROTATING TABLE FOR MITER CUTTING

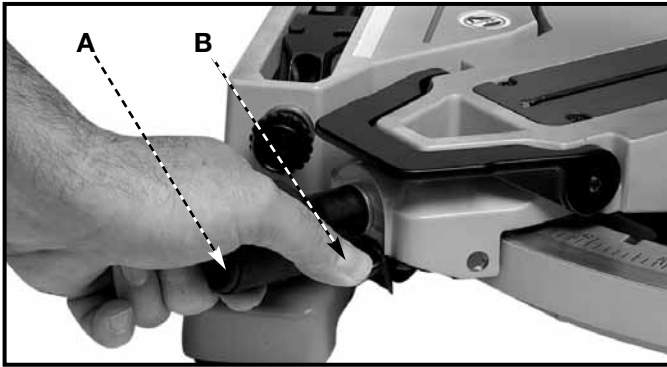

Fig. 13

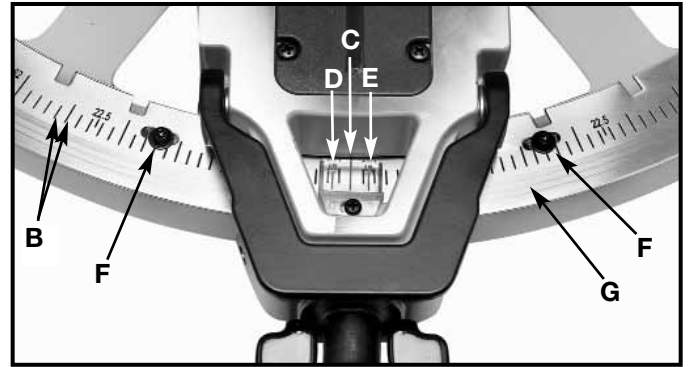

Fig. 14

1. The compound miter saw will cut any angle from a straight 0° cut to 48° right and left. Turn the locking knob (A) Fig. 13 counterclockwise, depress the lock lever (B), and rotate the table to the desired position.
2. This machine is equipped with positive stops at the 0° cut-off position and at the 15° , 22.5° , 31.6° , and 45° left and right positions.
3. The center line (C) Fig. 14 on the cursor indicates the actual angle of cut. Each scale line (B) represents 1° . When the center line (C) is moved from one line to the next on the scale, the angle of the cut is changed by 1° .
4. The pointer is provided with two additional lines (D) and (E), Fig. 14. This allows movement of the control arm by exactly $1/2^\circ$. For example, assume that the center line (C) is pointing to the 10° mark on the scale, as indicated, and the desired angle of cut is $1/2^\circ$ to the right. Move the control arm until the right line (E) lines up with the next line on the scale. The angle of cut will then be changed $1/2^\circ$ to the right. If you change the angle of cut $1/2^\circ$ to the left, use the left line (D) in the same manner.

ADJUSTING SLIDING FIT BETWEEN MOVABLE TABLE AND BASE

⚠ WARNING DISCONNECT THE MACHINE FROM THE POWER SOURCE.

To adjust the sliding fit between the movable table and the base, turn the nut (A) Fig. 15 clockwise to tighten the fit (counterclockwise to loosen the fit). This adjustment should not be so tight that it restricts the rotating movement of the table, or so loose that it affects the accuracy of the saw.

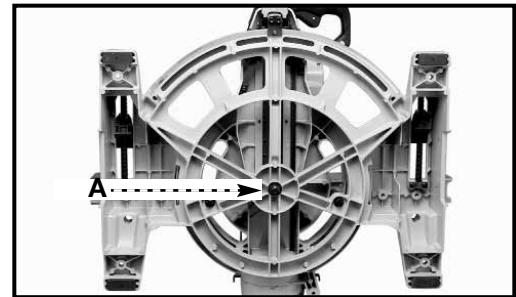

Fig. 15

ADJUSTING FENCE 90° TO BLADE

IMPORTANT: before making this adjustment, SET the blade at 0° to the table. (See section “Adjusting 0° , 33.9° , and 45° bevel positive stops.”)

⚠ WARNING DISCONNECT THE MACHINE FROM THE POWER SOURCE.

1. The right fence base (A) Fig. 16 is properly aligned at the factory. However, should adjustment of the right fence be necessary, loosen the bolts (D) and position the base (A) against the shoulders (C). Tighten the bolts (D) securely. **NOTE:** The right side sliding fence segment has been removed for this illustration.
2. Rotate the movable table (A) Fig. 16A so that the blade (C) is 90° to the right fence.
3. Adjust the front miter scale (B) Fig. 16A so that the 0° notch is engaged.

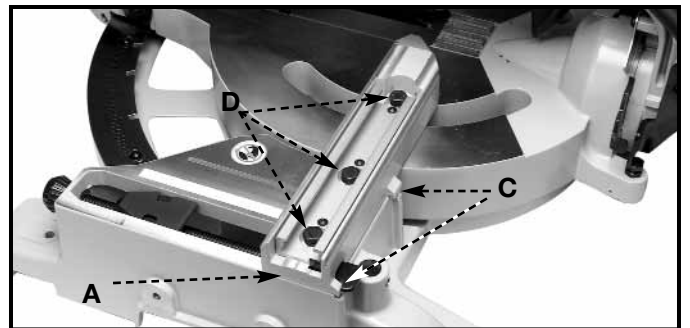

Fig. 16

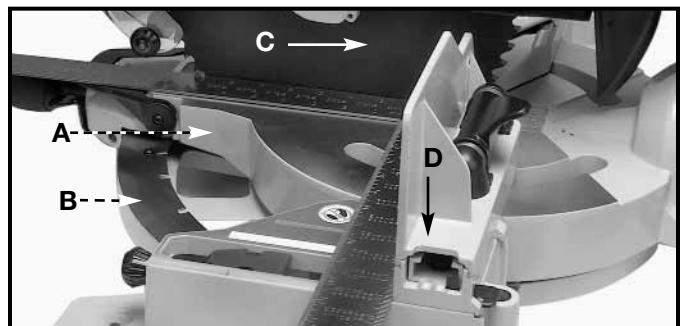

Fig. 16A

- Adjust the miter cursor (F) Fig. 17 so that the pointer is aligned with the 0° mark on the scale by loosening the screw (G), adjusting the cursor (F), and tightening the screw (G).
- Place one end of a framing square (A) Fig. 18 against the front of the right fence base (B) and the other end against the left fence base (C). Using the supplied wrench (D) Fig. 18, loosen the left fence base mounting screws and adjust the left fence base parallel to the right fence base.

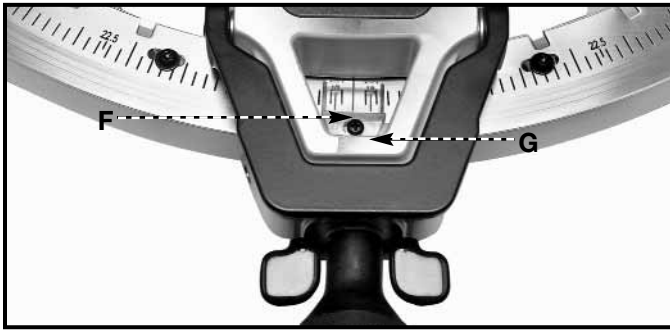

Fig. 17

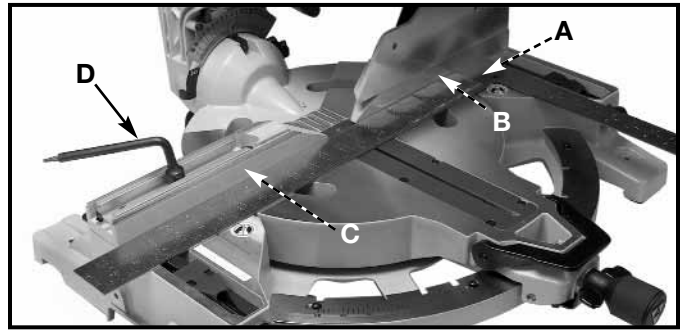

Fig. 18

TABLE HAZARD ZONE

⚠ WARNING THE AREA INSIDE THE TWO RED LINES (A) FIG. 21 ON THE TABLE IS DESIGNATED AS A HAZARD ZONE. **NEVER** PLACE YOUR HAND(S) INSIDE THE "TABLE HAZARD ZONE" (WITHIN THE RED LINES) WHILE THE TOOL IS BEING OPERATED. CLAMP ALL WORKPIECES WHICH WOULD CAUSE YOUR HAND(S) TO BE WITHIN THE RED LINES.

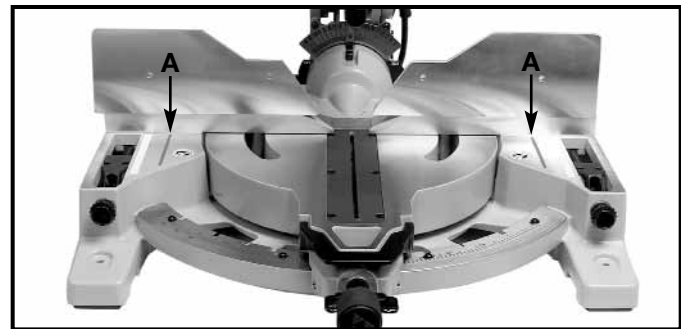

Fig. 21

TILTING CUTTINGHEAD FOR BEVEL CUTTING

⚠ WARNING DISCONNECT MACHINE FROM POWER SOURCE.



Fig. 22

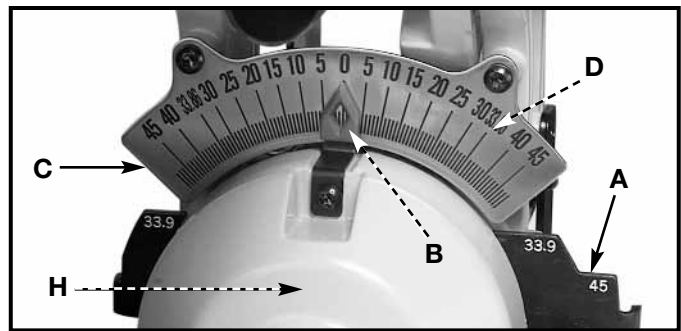

Fig. 23

IMPORTANT: Move the sliding fences to provide clearance for the blade and guard. The DEGREE of tilt determines how far to move the sliding fences. Refer to the section "fence OPERATION."

- The cuttinghead of your compound miter saw can be tilted to cut any bevel angle from a 90° straight cut-off to a 48° bevel angle left or right. Raise bevel lock lever (A) Fig. 22.
- Positive stops (A) Fig. 23 are provided to rapidly position the saw blade at 0°, 33.9° and 45°. Refer to the section of this manual titled "**ADJUSTING 0°, 33.9° AND 45° BEVEL POSITIVE STOPS.**" The bevel angle of the cutting head is determined by the position of the pointer (B) on the scale (C).
- In addition, a marked indicator (D) is provided on the bevel scale (33.9°) for cutting crown moulding. Refer to the "**CUTTING CROWN MOULDING**" section of this manual.

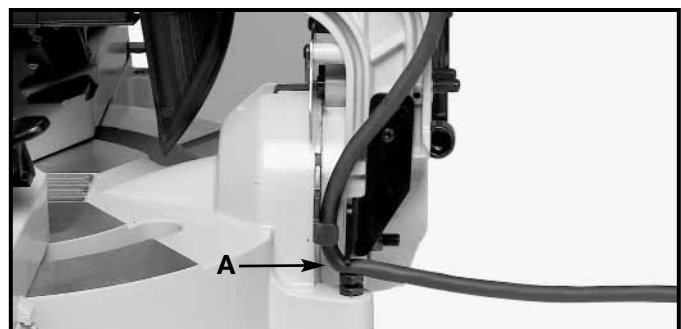

Fig. 23A

⚠ WARNING TAKE CARE NOT TO PINCH THE CORD (A) FIG. 23A WHEN TILTING THE CUTTINGHEAD.

SELECTING 0°, 33.9° AND 45° BEVEL POSITIVE STOPS

The bevel setting feature utilizes a sliding plate (A) Fig. 24, pin (B), and bushing (C) design that is used to select the bevel angle. The position of the pin (B) and the sliding plate (A) determine the bevel angle.

⚠ WARNING DISCONNECT THE MACHINE FROM THE POWER SOURCE.

1. Position the bevel detent plate so that the desired angle (A) Fig. 23 is exposed immediately to the left or right of the housing (H) Fig. 23.
2. Lift the front handle (A) Fig. 22 to disengage bevel lock.
3. Tilt the cuttinghead left or right as desired until it stops on plate (A) Fig. 23. **NOTE:** Shown from the rear, Fig. 25 illustrates the sliding plate positioned for 33.9° right and Fig. 26 illustrates the sliding plate positioned for 33.9° left.
4. Lower the front handle to engage the bevel lock.

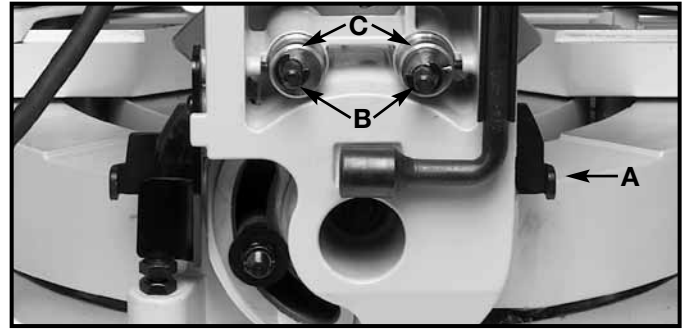

Fig. 24

NOTE: To perform a bevel cut of more than 45°, pull the bevel pin (B) out to bypass the bevel detent plate. 48° left or right is possible.

⚠ WARNING MAKE SURE THAT THE FENCES ARE CLEAR OF THE GUARD AND BLADE BEFORE USING SAW.

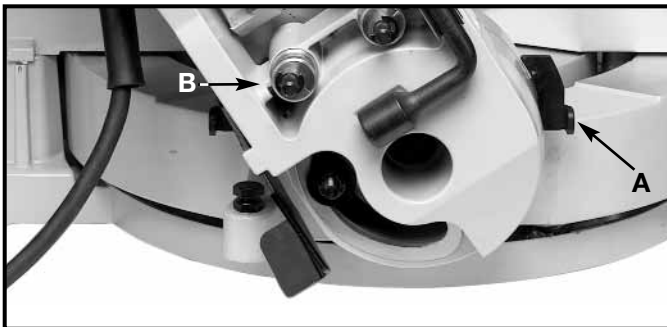

Fig. 25

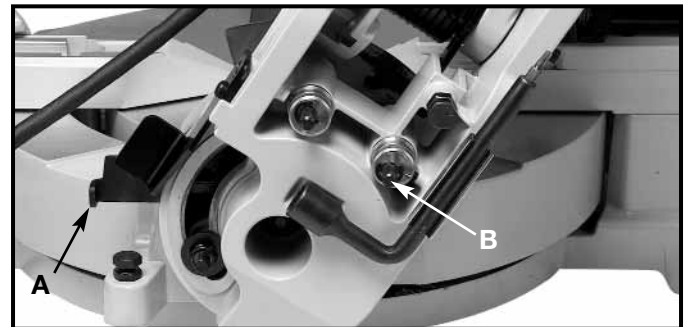

Fig. 26

ADJUSTING 0°, 33.9°, AND 45° BEVEL POSITIVE STOPS

The bevel adjustment utilizes a sliding plate (A) Fig. 24, pin (B), and bushing (C) design feature that can be adjusted to fine-adjust the bevel angle. The position of the pin within the bushing is adjustable and, when set, determines the bevel angle. To adjust, loosen the pin locking set screw(s) (D) Fig. 29 (shown from the rear), located on the side of the trunnion and rotate the bushing (C) to the desired location. Rotate the left bushing clockwise to increase and counterclockwise to decrease the bevel angle. Tighten screw(s) (D) securely.

⚠ WARNING DISCONNECT THE MACHINE FROM THE POWER SOURCE.

1. Position the bevel detent plate so that the desired angle (A) Fig. 27 is exposed.
2. Lift the front handle (A) Fig. 28 to disengage the bevel lock.
3. Tilt the cuttinghead left or right as desired until it stops on the plate (A) Fig. 27.
4. To adjust, loosen the pin locking set screw(s) (D) Fig. 29 (shown from the rear), located on the side of the trunnion and rotate the bushing (C) to the desired location. Rotate the left bushing clockwise to increase and counterclockwise to decrease the bevel angle. Tighten screw(s) (D) securely.

NOTE: The right bushing adjustment is opposite the left.



Fig. 27



Fig. 28

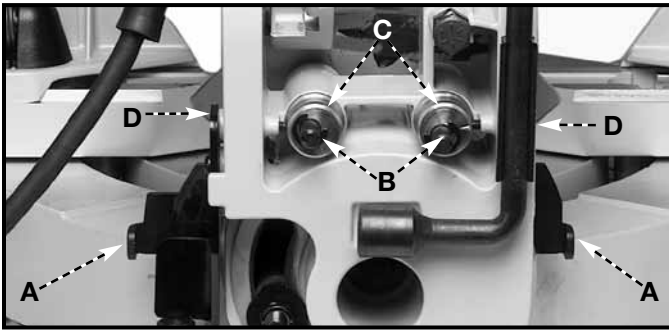

Fig. 29

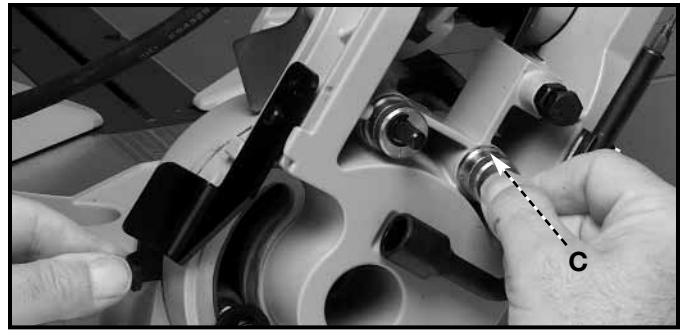

Fig. 30

NOTE: Shown from the rear, Fig. 30 illustrates the sliding plate position and bushing (C) adjustment for 45° left and Fig. 31 illustrates the sliding plate position and bushing (C) adjustment for 45° right.

⚠ WARNING MAKE SURE THAT THE FENCES ARE CLEAR OF THE GUARD AND BLADE BEFORE OPERATING THE SAW.



Fig. 31

ADJUSTING THE BEVEL LOCK

The bevel-locking force has been set at the factory. After a period of time, you may need to adjust the locking mechanism. To adjust, place the bevel-locking handle (A) Fig. 28 in the “UP” position and tighten the nut (A) Fig. 33.

ADJUSTING SLIDING FIT BETWEEN TRUNNION AND BEVEL BRACKET

After a period of time, it may become necessary to adjust the sliding fit between the trunnion and the bevel bracket by tightening the adjusting nut (C) Fig. 33 at the rear of the tool.

Correct adjustment provides a snug sliding fit between these two parts. This adjustment should not be so tight that it restricts the tilting movement of the trunnion when bevel cutting, or so loose that it affects the accuracy of the saw cut.

ADJUSTING THE TENSION OF CUTTINGHEAD RETURN SPRING

The tension of the cuttinghead return spring has been adjusted at the factory so that the cuttinghead returns to the “up” position after a cut has been made. To re-adjust the spring tension, loosen the nut (A) Fig. 34 and turn the adjusting screw (B) Fig. 34 clockwise to increase, or counterclockwise to decrease the spring tension. Tighten nut (A) securely.

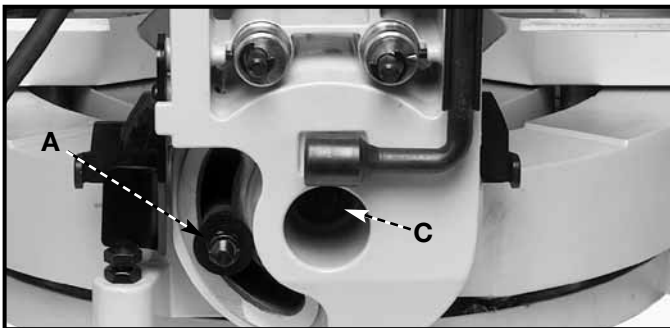

Fig. 33

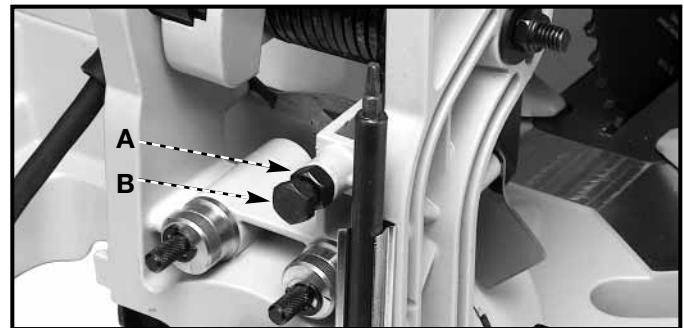

Fig. 34

ADJUSTING SLIDING FIT BETWEEN CUTTINGHEAD ARM AND TRUNNION

After a period of time, an adjustment of the sliding fit between the cuttinghead arm (B) Fig. 35, and the trunnion (C) may be necessary. To adjust, tighten or loosen the nut (D). Correct adjustment provides a snug sliding fit between these two parts. This adjustment should not be so tight that it restricts the sliding movement of the cuttinghead arm (B) or so loose that it affects the accuracy of the saw cut.

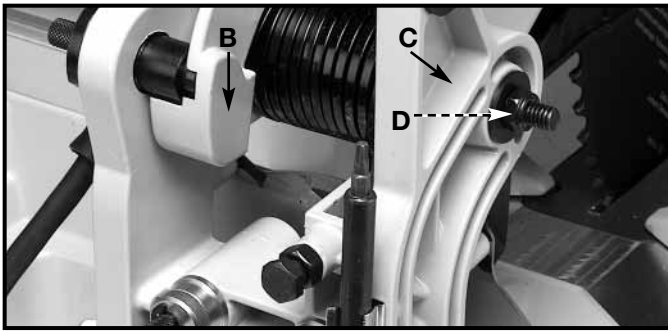

Fig. 35

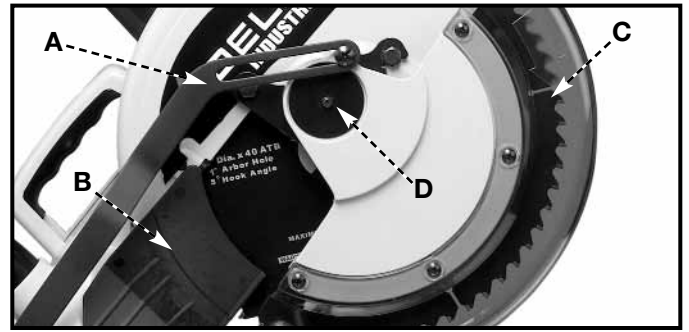

Fig. 36

ADJUSTING LOWER BLADE GUARD

The 36-412 incorporates an moveable lower blade guard (C) Fig. 36, and it also has a secondary blade guard (B) to cover the rear section of the blade. After an extended period of use, the moveable lower blade guard (C) Fig. 36 may not operate smoothly when the cuttinghead is lowered. This can be corrected by adjusting nut (D) until the lower blade guard (C) moves freely.

⚠ WARNING OVERTIGHTENING THE NUT COULD IMPAIR GUARD MOVEMENT.

NOTE: This unit has been designed with an articulating rear guard. Before contacting the workpiece, the rear guard will rotate upward to expose more of the blade as the cuttinghead is lowered.

⚠ WARNING DO NOT REMOVE ANY OF THE BLADE GUARDS. MAKE SURE THAT ALL GUARDS ARE IN PLACE AND FUNCTIONING PROPERLY BEFORE OPERATING THE SAW. MAKE SURE THAT THE FENCES ARE CLEAR OF THE GUARD AND BLADE BEFORE OPERATING THE SAW.

MACHINE USE

TYPICAL OPERATIONS AND HELPFUL HINTS

⚠ WARNING Keep your hands out of the hazard zone while operating the saw. If the size of the workpiece would cause your hand to be inside the table hazard zone (see section “**TABLE HAZARD ZONE**” SEE FIG. 21), use a clamp to secure the workpiece.

1. Before cutting, make certain that the cutting arm and table area are at their correct settings and firmly locked in place.
2. Before cutting, determine that the workpiece is the right size for the saw.
3. Place the workpiece on the table and hold or clamp it firmly against the fence.
4. For best results, cut at a slow, even cutting rate.
5. Never attempt freehand cutting (cutting a workpiece that is not held firmly against the fence and table).

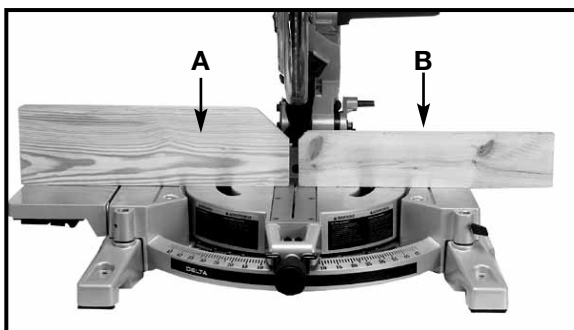

Fig. 37



Fig. 38

AUXILIARY WOOD FENCE

⚠ WARNING When performing multiple or repetitive cut-off operations that result in small cut-off pieces (one inch or less), the saw blade can catch the cut-off pieces and project them out of the machine or into the blade guard and housing, possibly causing damage and/or injury. In order to limit the possibility of personal injury or blade guard damage, mount an auxiliary wood fence to your saw.

Holes are provided in the fence to attach an auxiliary fence (A) and (B) (Fig. 37). This auxiliary fence is constructed of straight wood approximately 1/2” thick. Both sides A and B should be approximately 5.25” high by 11.5 inches long.

NOTE: The auxiliary fence (A) is used **only** with the saw blade in the 0° bevel position (90°) to the table. The auxiliary fence must be removed for all bevel cuts (blade tilted).

⚠ WARNING MAKE SURE THAT THE FENCES ARE CLEAR OF THE GUARD AND BLADE BEFORE OPERATING SAW.

AUXILIARY FENCE SPACER

This machine is supplied with new design features that increase cutting capacity. The unit can (1) crosscut 4" x 6" dimensional lumber at 0° miter and 0° bevel, (2) miter left and right 45° 4" x 4" dimensional lumber, and (3) bevel right 45° 2" x 8" dimensional lumber with a user provided spacer (A) Fig. 38.

NOTE: The spacer can be made from a 2" x 4" or any other 2" material as shown in Fig. 38.

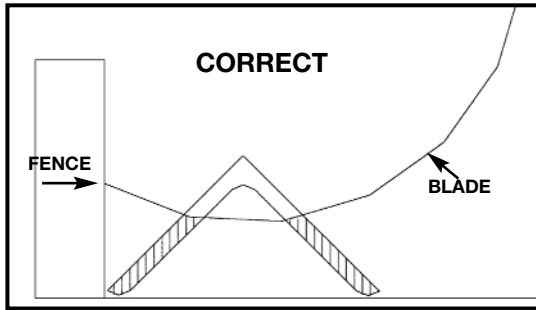

Fig. 39

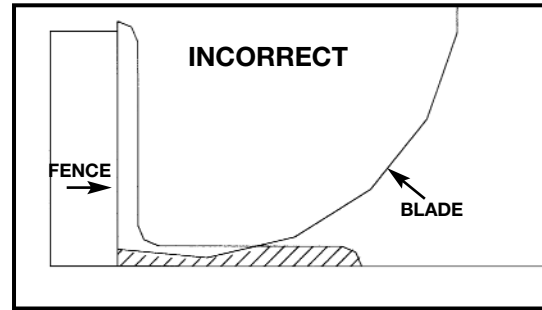

Fig. 40

CUTTING ALUMINUM

⚠WARNING TO REDUCE THE RISK OF INJURY, USE THE PROPER BLADE WHEN CUTTING THIS TYPE OF MATERIAL.

Aluminum extrusions (aluminum screens and storm windows) can easily be cut with your miter saw. When cutting aluminum extrusions, or other sections that can be cut with a saw blade and are within the capacity of the machine, position the material so that the blade is cutting through the smallest cross-section, as shown in Fig. 39. The wrong way to cut aluminum angles is illustrated in Fig. 40. Be sure to apply a stick wax (similar to Johnson's stick wax #140) to the blade before cutting any aluminum stock. This stick wax is available at most industrial mill supply houses. The stick wax provides proper lubrication and keeps chips from adhering to the blade.

⚠WARNING NEVER APPLY LUBRICANT TO THE BLADE WHILE THE SAW IS RUNNING.

CUTTING BOWED MATERIAL

1. Check the workpiece. If it is bowed, position the workpiece on the table as shown in Fig. 41.
2. When the workpiece is positioned the wrong way (Fig. 42), it will pinch the blade near the completion of the cut.

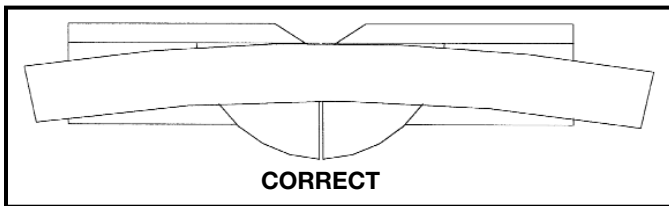

Fig. 41

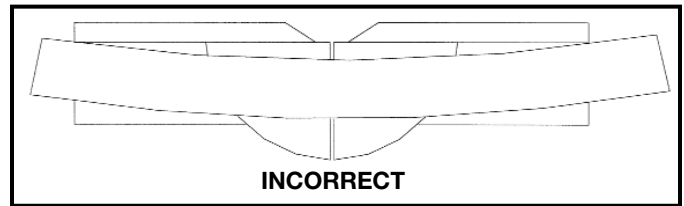

Fig. 42

CONSTRUCTING WORK SUPPORT EXTENSIONS

For support when cutting long pieces, construct a work support extension. Fig. 42A illustrates the miter saw mounted on two standard 2 x 4's (A). Fasten the four mounting legs (two of which are shown at (B) Fig. 42A to the 2 x 4's, using four screws (not supplied) through the four holes in the mounting legs. The length of the 2 x 4's (A) can vary, depending on the workpiece.

NOTE: Make sure that the top of the support 2 x 4's (C) are level with the miter saw table.

This is critical because the distance from the top of the 2 x 4's (A) to the miter saw table varies from saw to saw. In most cases, standard 2 x 4's (C) can be used. If these are too high, cut them to fit. If the 2 x 4's are too low, use 2 x 6's. If these are high, cut them to the correct height.

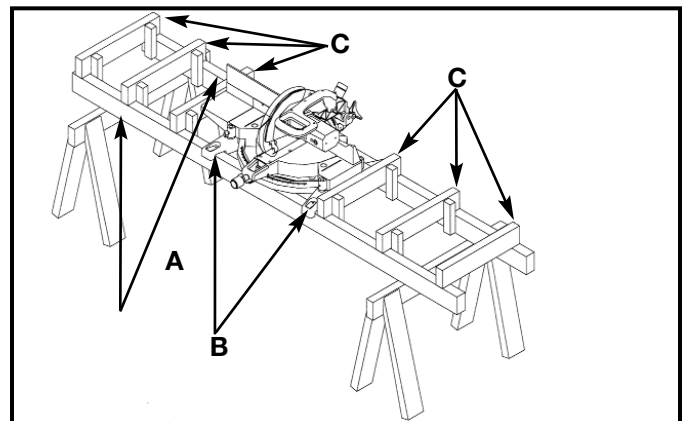

Fig. 42A

CUTTING CROWN MOULDING (USING BUILT-IN STOPS)

Crown moulding stops have been built into the base to aid in holding the workpiece in position while cutting. This new design feature allows cutting crown moulding in either the flat or nested position and utilizes a stop and screw feature that can be quickly adjusted to accommodate several widths of crown moulding. The position of the stops can be adjusted by two methods. To adjust, turn knob (A) Fig. 43 until stop (B) is in the proper position to mount the crown moulding at the selected angle, or, squeeze the ears and depress the stop (A) Fig. 44 to disengage the stop (B) Fig. 43 from the screw. Then move the stop to the desired location and raise the stop until the ears snap in place (B) Fig. 45. Then if necessary turn knob(s) (A) Fig. 45 to fine adjust the stop. A recessed slot (D) Fig. 44 is provided for the user to add pencil markings to establish various quick reference stop positions.

⚠ WARNING MAKE SURE THAT THE FENCES ARE CLEAR OF THE GUARD AND BLADE BEFORE USING SAW.

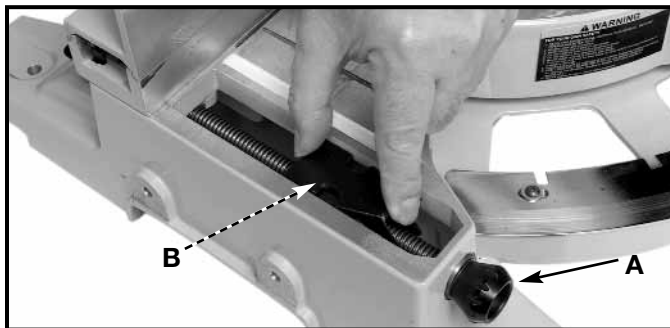

Fig. 43

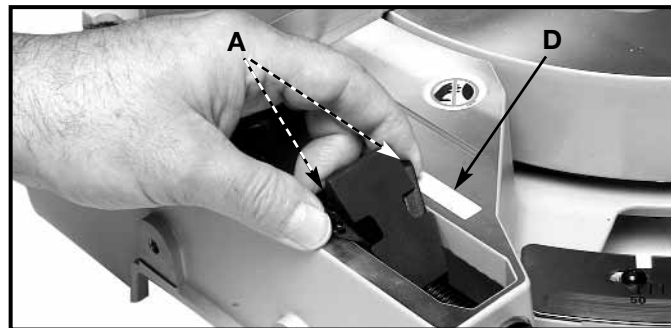

Fig. 44

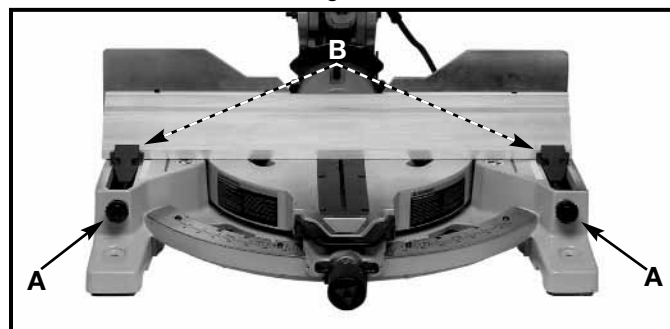

Fig. 45

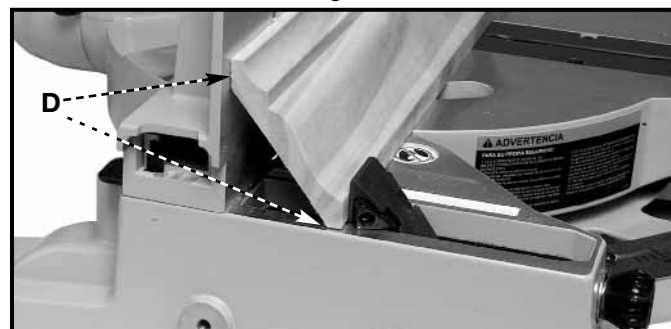

Fig. 46

When cutting crown moulding using the crown moulding stops, do not bevel the cut. The crown moulding stop feature is designed to make the cut with the cuttinghead at 90° and with the table rotated 45°.

1. Move the table to the 45° right miter position and lock the table in position. NOTE: A positive stop is provided to find this angle quickly.
2. Place the crown moulding in the "nested" position between the fence and table with the ceiling edge on the base and the wall edge against on the fence, as shown in Fig. 46. Make sure the flats of the molding, (D) Fig. 46, are even with the fence and the table as shown. Make the cut.

NOTE: The piece of crown moulding used for the inside corner will always be on the right side of the blade, as shown at (A) Fig. 46A. The piece of crown moulding used for the outside corner will always be on the left side of the blade, as shown at (B) Fig. 46A.

4. To make the matching halves of the inside and outside corners, rotate the table to the 45° left miter position.

NOTE: A positive stop is provided to find this angle quickly.

5. Place the crown moulding on the table as described in step 2 and make the cut. In this case, the piece of crown moulding used for the outside corner will always be on the right side of the blade, as shown at (C) Fig. 46B. The piece of crown moulding used for the inside corner will always be on the left side of the blade, as shown at (D) Fig. 46B.
6. Fig. 46C illustrates the two outside corner pieces; the piece cut at (B) Fig. 46A, and the piece cut at (C) Fig. 46B.
7. Fig. 46D illustrates the two inside corner pieces; the piece cut at (D) Fig. 46B, and the piece cut at (A) Fig. 46A.

⚠ WARNING A NEW FEATURE FOR THIS TOOL IS CROWN MOULDING STOPS BUILT INTO THE BASE. DELTA DOES NOT CONSIDER THE CROWN MOULDING STOPS TO BE WORK CLAMPS AND THEY ARE NOT TO BE USED IN THIS MANNER.

⚠ WARNING MAKE SURE THAT THE FENCES ARE CLEAR OF THE GUARD AND BLADE BEFORE OPERATING THE SAW.

⚠ WARNING WHEN CUTTING CROWN MOULDING USING THE CROWN MOULDING STOPS, DO NOT BEVEL THE CUT. THE CROWN MOULDING STOP FEATURE IS DESIGNED TO MAKE THE CUT WITH THE CUTTINGHEAD AT 90° AND WITH THE TABLE ROTATED 45°.

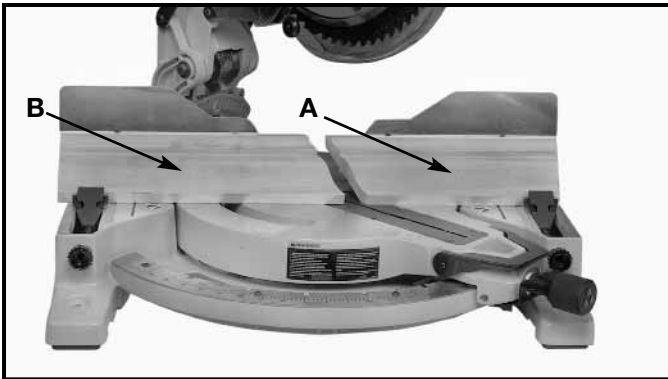

Fig. 46A

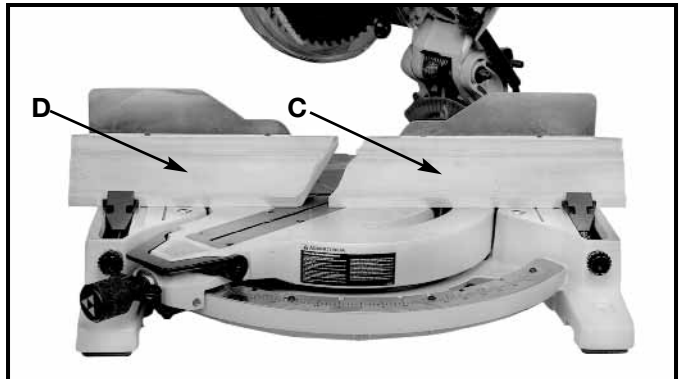

Fig. 46B

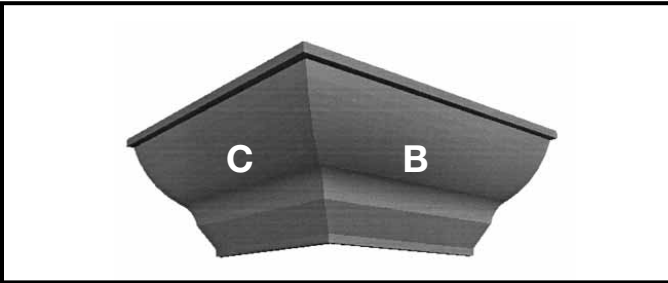

Fig. 46C

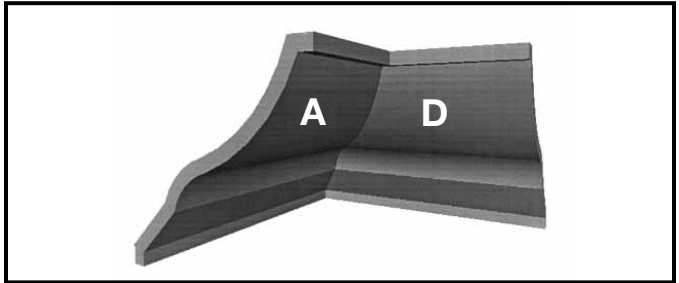

Fig. 46D

CUTTING CROWN MOULDING (FLAT POSITION)

One of the many features of the saw is the ease of cutting crown moulding. The following is an example of cutting both inside and outside corners on **52°/38°** wall angle crown moulding.

1. Move the table to the **31.62°** right miter position and lock the table in position. **NOTE:** A positive stop is provided to find this angle quickly.
2. Tilt the saw blade to the **33.86°** left bevel position and tighten bevel lock handle. **NOTE:** A triangle indicator is provided on the bevel scale to find this angle quickly.
3. Place the crown moulding on the table with the **CEILING EDGE** of the moulding against the fence, and make the cut, as shown in Fig. 47.

NOTE: The piece of crown moulding used for the outside corner will always be on the right hand side of the blade, as shown at (A) Fig. 47. The piece of crown moulding used for the inside corner will always be on the left hand side of the blade, as shown at (B) Fig. 47.

4. To make the matching halves of the inside and outside corners, rotate the table to the **31.62°** left miter position.

NOTE: A positive stop is provided to find this angle quickly. The saw blade is already tilted to the **33.86°** bevel position from the previous cut.

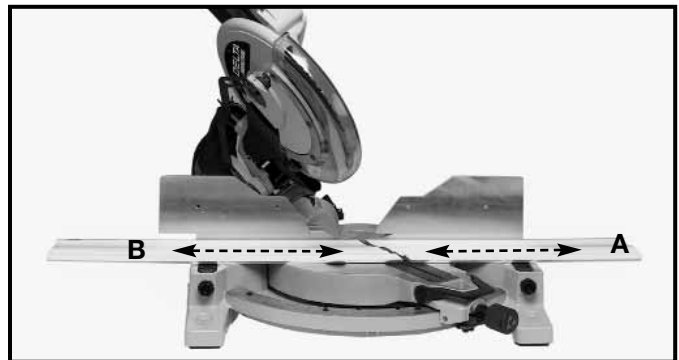

Fig. 47

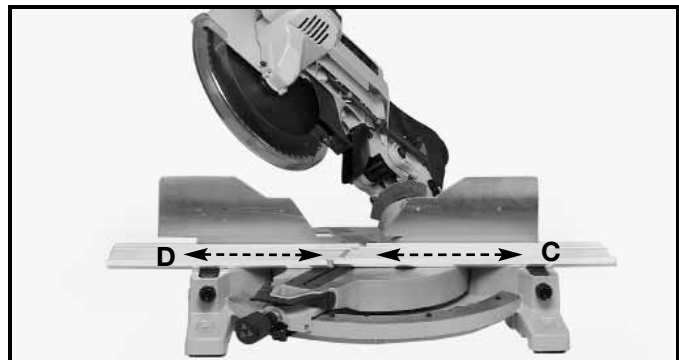

Fig. 48

- Place the crown moulding on the table with the **WALL EDGE** of the crown moulding against the fence and make the cut. Again, the piece of crown moulding used for the outside corner will always be on the right side of the blade, as shown at (C) Fig. 48. The piece of crown moulding used for the inside corner will always be on the left side of the blade, as shown at (D) Fig. 48.
- Fig. 49 illustrates the two outside corner pieces; (1) being the piece cut at (A) Fig. 47 and (2) being the piece cut at (C) Fig. 48.
- Fig. 50 illustrates the two inside corner pieces; (1) being the piece cut at (B) Fig. 47, and (2) being the piece cut at (D) Fig. 48.

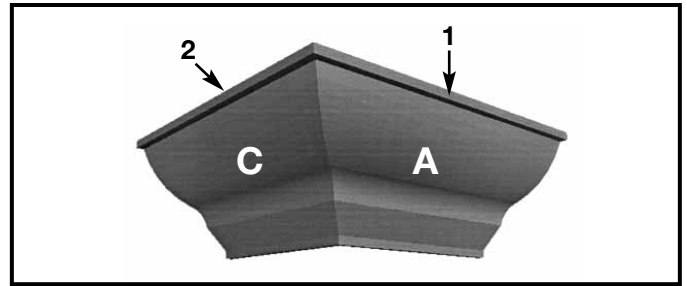

Fig. 49

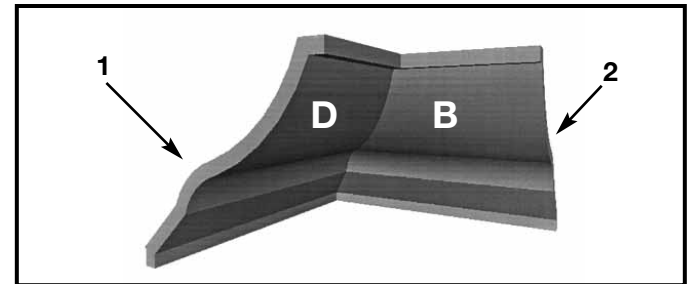

Fig. 50

45-45 CROWN MOULDING

NOTE: If you are cutting crown moulding that is 45°-45°, follow the same procedure above, with the exception that the bevel position will always be at 30° and the miter position will be 35-1/4° to the right or left.

OTHER ANGLES

NOTE: The above instructions are assuming the angle between the walls is 90°. If you need help cutting crown moulding for walls set at angles other than 90°, see the instruction sheet “**CUTTING CROWN MOULDING**” on the Delta Machinery web site at www.deltamachinery.com.

TROUBLESHOOTING

For assistance with your machine, visit our website at www.deltamachinery.com for a list of service centers or call the DELTA Machinery help line at 1-800-223-7278 (In Canada call 1-800-463-3582).

MAINTENANCE

KEEP MACHINE CLEAN

Periodically blow out all air passages with dry compressed air. All plastic parts should be cleaned with a soft damp cloth. NEVER use solvents to clean plastic parts. They could possibly dissolve or otherwise damage the material.

▲WARNING WEAR ANSI Z87.1 SAFETY GLASSES WHILE USING COMPRESSED AIR.

FAILURE TO START

Should your machine fail to start, check to make sure the prongs on the cord plug are making good contact in the outlet. Also, check for blown fuses or open circuit breakers in the line.

LUBRICATION

Apply household floor paste wax to the machine table and extension table or other work surface weekly.

PROTECTING CAST IRON FROM RUST

To clean and protect cast iron tables from rust, you will need the following materials: 1 pushblock from a jointer, 1 sheet of medium Scotch-Brite™ Blending Hand Pad, 1 can of WD-40®, 1 can of degreaser, 1 can of TopCote® Aerosol. Apply the WD-40 and polish the table surface with the Scotch-Brite pad using the pushblock as a holddown. Degrease the table, then apply the TopCote® accordingly.

CHANGING THE BLADE

The 36-412 incorporates a moveable lower blade guard, and it also has a secondary blade guard to cover the rear section of the blade. Make sure there is minimal gap between the two guards when the cuttinghead is in its uppermost position.

⚠ WARNING MAKE SURE THAT THE FENCES ARE CLEAR OF THE GUARD AND BLADE BEFORE USING SAW.

⚠ WARNING OVER-TIGHTENING THE NUT COULD IMPAIR GUARD MOVEMENT.

⚠ WARNING DO NOT REMOVE ANY OF THE BLADE GUARDS.

⚠ WARNING MAKE SURE THAT ALL GUARDS ARE IN PLACE AND FUNCTIONING PROPERLY BEFORE OPERATING THE SAW.

⚠ WARNING USE ONLY CROSS-CUTTING SAW BLADES. DO NOT USE BLADES WITH DEEP GULLETS. THEY CAN DEFLECT AND CONTACT THE GUARD.

⚠ WARNING DISCONNECT THE MACHINE FROM THE POWER SOURCE.



Fig. 51



Fig. 52

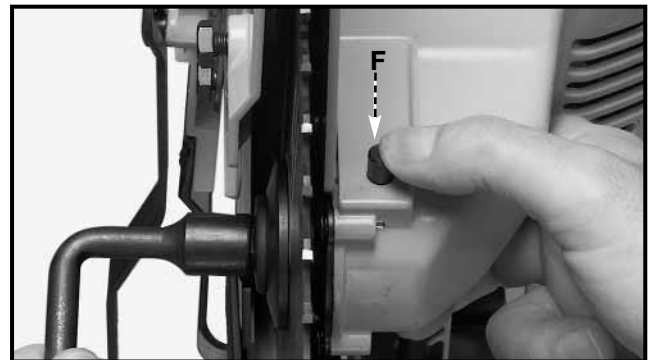

Fig. 53

1. Use only a 12" diameter blade, with 1" arbor hole, that is rated for **5000 RPM** or higher.
2. Loosen screws (A) Fig. 51 with the supplied wrench (B).
3. Rotate the arbor cover (C) Fig. 52, and move the guard (D) Fig. 52 to the rear, exposing the arbor screw (E). **NOTE: Do not remove the rear guard (J) Fig. 52.**
4. Remove the arbor screw (E) Fig. 52, by turning screw clockwise with wrench (supplied), while pressing in on arbor lock (F) Fig. 53. Remove the outside blade flange (G) Fig. 52, and saw blade (H) Fig. 52. **Do not remove the inside blade flange.**
5. Attach the new saw blade. Ensure that the **teeth of saw blade are pointing down at the front**, and attach the outside blade flange (G) Fig. 52. Check to see that the flats on the outside blade flange are engaged with the flats on the arbor shaft.
6. Thread the arbor screw (E) Fig. 52, into the saw arbor by turning the screw (E) counterclockwise as far as possible by hand. Tighten the arbor screw (E) with the supplied wrench while pressing in on the arbor lock (F) Fig. 53.
7. Rotate the arbor cover (C) Fig. 52, and move the guard (D) to the front. Tighten the screws (A) that were loosened in **STEP 2.**

CAUTION MAKE SURE THAT THE ARBOR LOCK IS DISENGAGED BEFORE STARTING THE MACHINE.

BRUSH INSPECTION AND REPLACEMENT

⚠ WARNING BEFORE INSPECTING BRUSHES, DISCONNECT THE MACHINE FROM THE POWER SOURCE.

Brush life varies, depending on the load on the motor. Check the brushes after the first 50 hours, or after a new set of brushes has been installed.

After the first check, examine them about every 10 hours.

The brush holders (A) Fig. 54 are located on the motor housing opposite each other. Remove the brush holder cap (A) Fig. 55, and remove the brushes for inspection. When the carbon on either brush (B) is worn to 3/16" or less, or if either spring or shunt wire (C) is burned or damaged, replace both brushes. If the brushes are found serviceable after removing, reinstall them in the same position.

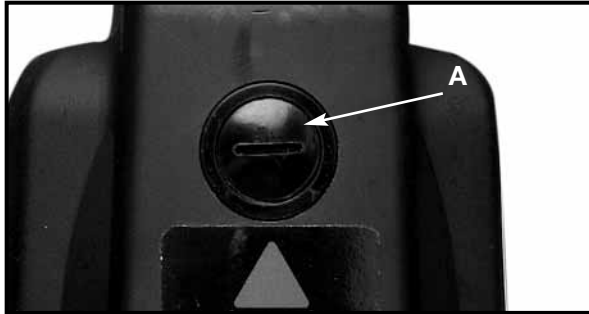

Fig. 54



Fig. 55

SERVICE



PARTS, SERVICE OR WARRANTY ASSISTANCE

All Delta Machines and accessories are manufactured to high quality standards and are serviced by a network of Porter-Cable • Delta Factory Service Centers and Delta Authorized Service Stations. To obtain additional information regarding your Delta quality product or to obtain parts, service, warranty assistance, or the location of the nearest service outlet, please call 1-800-223-7278 (In Canada call 1-800-463-3582).

ACCESSORIES

A complete line of accessories is available from your Delta Supplier, Porter-Cable • Delta Factory Service Centers, and Delta Authorized Service Stations. Please visit our Web Site www.deltamachinery.com for a catalog or for the name of your nearest supplier.

⚠ WARNING SINCE ACCESSORIES OTHER THAN THOSE OFFERED BY DELTA HAVE NOT BEEN TESTED WITH THIS PRODUCT, USE OF SUCH ACCESSORIES COULD BE HAZARDOUS. FOR SAFEST OPERATION, ONLY DELTA RECOMMENDED ACCESSORIES SHOULD BE USED WITH THIS PRODUCT.

WARRANTY



Two Year Limited New Product Warranty

Delta will repair or replace, at its expense and at its option, any new Delta machine, machine part, or machine accessory which in normal use has proven to be defective in workmanship or material, provided that the customer returns the product prepaid to a Delta factory service center or authorized service station with proof of purchase of the product within two years and provides Delta with reasonable opportunity to verify the alleged defect by inspection. For all refurbished Delta product, the warranty period is 180 days. Delta may require that electric motors be returned prepaid to a motor manufacturer's authorized station for inspection and repair or replacement. Delta will not be responsible for any asserted defect which has resulted from normal wear, misuse, abuse or repair or alteration made or specifically authorized by anyone other than an authorized Delta service facility or representative. Under no circumstances will Delta be liable for incidental or consequential damages resulting from defective products. This warranty is Delta's sole warranty and sets forth the customer's exclusive remedy, with respect to defective products; all other warranties, express or implied, whether of merchantability, fitness for purpose, or otherwise, are expressly disclaimed by Delta.

PORTER-CABLE • DELTA SERVICE CENTERS (CENTROS DE SERVICIO DE PORTER-CABLE • DELTA)

Parts and Repair Service for Porter-Cable • Delta Machinery are Available at These Locations
(Obtenga Refaccion de Partes o Servicio para su Herramienta en los Siguietes Centros de Porter-Cable • Delta)

ARIZONA

Tempe 85282 (Phoenix)
2400 West Southern Avenue
Suite 105
Phone: (602) 437-1200
Fax: (602) 437-2200

CALIFORNIA

Ontario 91761 (Los Angeles)
3949A East Guasti Road
Phone: (909) 390-5555
Fax: (909) 390-5554

San Diego 92111
7638 Clairemont Blvd.
Phone: (858) 277-9595
Fax: (858) 277-9696

San Leandro 94577 (Oakland)
3039 Teagarden Street
Phone: (510) 357-9762
Fax: (510) 357-7939

COLORADO

Arvada 80003 (Denver)
8175 Sheridan Blvd., Unit S
Phone: (303) 487-1809
Fax: (303) 487-1868

FLORIDA

Davie 33314 (Miami)
4343 South State Rd. 7 (441)
Unit #107
Phone: (954) 321-6635
Fax: (954) 321-6638

Tampa 33609
4538 W. Kennedy Boulevard
Phone: (813) 877-9585
Fax: (813) 289-7948

GEORGIA

Forest Park 30297 (Atlanta)
5442 Frontage Road,
Suite 112
Phone: (404) 608-0006
Fax: (404) 608-1123

ILLINOIS

Addison 60101 (Chicago)
400 South Rohlwing Rd.
Phone: (630) 424-8805
Fax: (630) 424-8895

Woodridge 60517 (Chicago)
2033 West 75th Street
Phone: (630) 910-9200
Fax: (630) 910-0360

MARYLAND

Elkridge 21075 (Baltimore)
7397-102 Washington Blvd.
Phone: (410) 799-9394
Fax: (410) 799-9398

MASSACHUSETTS

Franklin 02038 (Boston)
Franklin Industrial Park
101E Constitution Blvd.
Phone: (508) 520-8802
Fax: (508) 528-8089

MICHIGAN

Madison Heights 48071 (Detroit)
30475 Stephenson Highway
Phone: (248) 597-5000
Fax: (248) 597-5004

MINNESOTA

Minneapolis 55429
5522 Lakeland Avenue North
Phone: (763) 561-9080
Fax: (763) 561-0653

MISSOURI

North Kansas City 64116
1141 Swift Avenue
Phone: (816) 221-2070
Fax: (816) 221-2897

St. Louis 63119
7574 Watson Road
Phone: (314) 968-8950
Fax: (314) 968-2790

NEW YORK

Flushing 11365-1595 (N.Y.C.)
175-25 Horace Harding Expwy.
Phone: (718) 225-2040
Fax: (718) 423-9619

NORTH CAROLINA

Charlotte 28270
9129 Monroe Road, Suite 115
Phone: (704) 841-1176
Fax: (704) 708-4625

OHIO

Columbus 43214
4560 Indianola Avenue
Phone: (614) 263-0929
Fax: (614) 263-1238

Cleveland 44125
8001 Sweet Valley Drive
Unit #19
Phone: (216) 447-9030
Fax: (216) 447-3097

OREGON

Portland 97230
4916 NE 122 nd Ave.
Phone: (503) 252-0107
Fax: (503) 252-2123

PENNSYLVANIA

Willow Grove 19090
(Philadelphia)
520 North York Road
Phone: (215) 658-1430
Fax: (215) 658-1433

TEXAS

Carrollton 75006 (Dallas)
1300 Interstate 35 N, Suite 112
Phone: (972) 446-2996
Fax: (972) 446-8157

Houston 77043
4321 Sam Houston Parkway,
West
Suite 180
Phone: (713) 983-9910
Fax: (713) 983-6645

WASHINGTON

Auburn 98001(Seattle)
3320 West Valley HWY, North
Building D, Suite 111
Phone: (253) 333-8353
Fax: (253) 333-9613

Authorized Service Stations are located in many large cities. Telephone **800-438-2486** or **731-541-6042** for assistance locating one. Parts and accessories for Porter-Cable-Delta products should be obtained by contacting any Porter-Cable-Delta Distributor, Authorized Service Center, or Porter-Cable-Delta Factory Service Center. If you do not have access to any of these, call **800-223-7278** and you will be directed to the nearest Porter-Cable-Delta Factory Service Center. Las Estaciones de Servicio Autorizadas están ubicadas en muchas grandes ciudades. Llame al **800-438-2486** ó al **731-541-6042** para obtener asistencia a fin de localizar una. Las piezas y los accesorios para los productos Porter-Cable-Delta deben obtenerse poniéndose en contacto con cualquier distribuidor Porter-Cable-Delta, Centro de Servicio Autorizado o Centro de Servicio de Fábrica Porter-Cable-Delta. Si no tiene acceso a ninguna de estas opciones, llame al **800-223-7278** y le dirigirán al Centro de Servicio de Fábrica Porter-Cable-Delta más cercano.

CANADIAN PORTER-CABLE • DELTA SERVICE CENTERS

ALBERTA

Bay 6, 2520-23rd St. N.E.
Calgary, Alberta
T2E 8L2
Phone: (403) 735-6166
Fax: (403) 735-6144

BRITISH COLUMBIA

8520 Baxter Place
Burnaby, B.C.
V5A 4T8
Phone: (604) 420-0102
Fax: (604) 420-3522

MANITOBA

1699 Dublin Avenue
Winnipeg, Manitoba
R3H 0H2
Phone: (204) 633-9259
Fax: (204) 632-1976

ONTARIO

505 Southgate Drive
Guelph, Ontario
N1H 6M7
Phone: (519) 767-4132
Fax: (519) 767-4131

QUÉBEC

1515 ave.
St-Jean Baptiste, Suite 160
Québec, Québec
G2E 5E2
Phone: (418) 877-7112
Fax: (418) 877-7123

1447, Begin
St-Laurent, (Montréal),
Québec
H4R 1V8
Phone: (514) 336-8772
Fax: (514) 336-3505

The following are trademarks of PORTER-CABLE • DELTA (Las siguientes son marcas registradas de PORTER-CABLE • DELTA S.A.) (Les marques suivantes sont des marques de fabrication de la PORTER-CABLE • DELTA): Auto-Set®, BAMMER®, B.O.S.S.®, Builder's Saw®, Contractor's Saw®, Contractor's Saw II™, Delta®, DELTACRAFT®, DELTAGRAM™, Delta Series 2000™, DURATRONIC™, Emc2™, FLEX®, Flying Chips™, FRAME SAW®, Grip Vac™, Homecraft®, INNOVATION THAT WORKS®, Jet-Lock®, JETSTREAM®, 'kickstand®, LASERLOC®, MICRO-SET®, Micro-Set®, MIDI LATHE®, MORTEN™, NETWORK™, OMNIJIG®, POCKET CUTTER®, PORTA-BAND®, PORTA-PLANE®, PORTER-CABLE®(design), PORTER-CABLE®PROFESSIONAL POWER TOOLS, PORTER-CABLE REDEFINING PERFORMANCE™, Posi-Matic®, Q-3®(design), QUICKSAND®(design), QUICKSET™, QUICKSET II®, QUICKSET PLUS™, RIPTIDE™(design), SAFE GUARD II®, SAFE-LOC®, Sanding Center®, SANDTRAP®(design), SAW BOSS®, Sawbuck™, Sidekick®, SPEED-BLOC®, SPEEDMATIC®, SPEEDTRONIC®, STAIR EASE®, The American Woodshop®(design), The Lumber Company®(design), THE PROFESSIONAL EDGE®, THE PROFESSIONAL SELECT®, THIN-LINE™, TIGER®, TIGER CUB®, TIGER SAW®, TORQBUSTER®, TORQ-BUSTER®, TRU-MATCH™, TWIN-LITE®, UNIGUARD®, Unifence®, UNIFEEDER™, Unihead®, Uniplane™, Unirip®, Unisaw®, Univise®, Versa-Feeder®, VERSA-PLANE®, WHISPER SERIES®, WOODWORKER'S CHOICE™.

Trademarks noted with ™ and ® are registered in the United States Patent and Trademark Office and may also be registered in other countries. Las Marcas Registradas con el signo de ™ y ® son registradas por la Oficina de Registros y Patentes de los Estados Unidos y también pueden estar registradas en otros países.