

DeVILBISS AIR POWER COMPANY

STEEL DRIVER SERIES

Operation, Maintenance, and Parts Manual for **FN7**

FINISHING NAILER

Specifications

MODEL	FN7
AIR INLET	1/4" NPT
WEIGHT	5 lbs.
LENGTH	11 7/8"
HEIGHT	11"
MAXIMUM PRESSURE	125 PSI
PRESSURE RANGE	65-100 PSI
FASTENER LENGTHS	3/4"-2"
MAGAZINE CAPACITY	100 Nails
SCFM REQUIRED @ 90 PSI	Every 10 Fasteners Delivered Per Minute Requires .41 SCFM
MINIMUM COMPRESSOR HP REQUIRED TO OPERATE	3/4 HP (TANK MOUNTED)

This manual contains information that is important for you to know and understand. This information relates to protecting YOUR SAFETY and PREVENTING EQUIPMENT PROBLEMS. PLEASE READ THIS MANUAL.

DeVilbiss Air Power Company • 213 Industrial Drive • Jackson, TN 38301-9615

MGP-FN7-1A 6/11/97

TABLE OF CONTENTS

	PAGE
Tool Specifications	Front Cover
Table of Contents	2
Limited Warranty	3
Safety Guidelines	4
Warning Chart	4-6
Lubrication and Maintenance	7-8
Recommended Hook-up	8
Contact Trip Safety Mechanism	9
A. Operating A Contact Trip Tool	
B. Checking The Operation Of Contact Trip Safety Mechanism	
Loading The Tool	10
Operating the Tool	10-11
Clearing A Jam From The Tool	11
Trouble Shooting Guide	12
Exploded View	13
Parts List	14
Parts Kits	14
Fasteners	15
Toll-Free 800 Number	Back Cover

LIMITED WARRANTY

ONE YEAR FROM DATE OF PURCHASE

All merchandise manufactured by DeVilbiss Air Power Company is warranted to be free of defects in workmanship and material which occur during the first year from the date of purchase by the original purchaser (initial user). Products covered under this warranty include: air compressors, *air tools, accessories, service parts, pressure washers, and generators used in consumer applications (i.e., personal residential household usage only).

Air compressors, *air tools, accessories, service parts, pressure washers, and generators used in commercial applications (income producing) are covered by a 90 day warranty.

DeVilbiss Air Power will repair or replace, at DeVilbiss's option, products or components which have failed within the warranty period. Repair or replacement, and service calls on 60 and 80 gallon air compressors, will be handled by Authorized Warranty Service Centers and will be scheduled and serviced according to the normal work flow and business hours at the service center location, and depending on the availability of replacement parts.

All decisions of DeVilbiss Air Power Company with regard to this policy shall be final.

This warranty gives you specific legal rights, and you may also have other rights which vary from state to state.

RESPONSIBILITY OF ORIGINAL PURCHASER (Initial User):

- Retain original cash register sales receipt as proof of purchase for warranty work.
- Use reasonable care in the operation and maintenance of the product as described in the Owners Manual(s).
- Deliver or ship the product to the nearest DeVilbiss Air Power Authorized Warranty Service Center. Freight costs, if any, must be paid by the purchaser.
- Air compressors with 60 and 80 gallon tanks only will be inspected at the site of installation. Contact the nearest Authorized Warranty Service Center, that provides on-site service calls, for service call arrangement.
- If the purchaser does not receive satisfactory results from the Authorized Warranty Service Center, the purchaser should contact DeVilbiss Air Power Company.

THIS WARRANTY DOES NOT COVER:

- Merchandise sold as reconditioned, floor models and/or display models. Any damaged or incomplete equipment sold "as is".
- Merchandise used as "rental" equipment.
- Merchandise that has become inoperative because of ordinary wear, misuse, freeze damage, use of improper chemicals, negligence, accident, improper and/or unauthorized repair or alterations including failure to operate the product in accordance with the instructions provided in the Owners Manual (s) supplied with the product.
*Air Tools: O-Rings and driver blades are considered ordinary wear parts, therefore, they are warranted for a period of 45 days from the date of purchase.
- An air compressor that pumps air more than 50% during a one hour period is considered misuse because the air compressor is undersized for the required air demand. Maximum compressor pumping time per hour is 30 minutes.
- Merchandise sold by DeVilbiss Air Power which has been manufactured by and identified as the product of another company. The product manufacturer's warranty will apply.
- Repair and transportation costs of merchandise determined not to be defective.
- Cost associated with assembly, required oil, adjustments or other installation and start-up cost.
- ANY INCIDENTAL, INDIRECT OR CONSEQUENTIAL LOSS, DAMAGE, OR EXPENSE THAT MAY RESULT FROM ANY DEFECT, FAILURE OR MALFUNCTION OF THE PRODUCT.** Some states do not allow the exclusion or limitation of incidental or consequential damages, so the above limitation or exclusion may not apply to you.
- IMPLIED WARRANTIES, INCLUDING THOSE OF MERCHANTABILITY AND FITNESS FOR A PARTICULAR PURPOSE, ARE LIMITED TO ONE YEAR FROM THE DATE OF ORIGINAL PURCHASE.** Some states do not allow limitations on how long an implied warranty lasts, so the above limitations may not apply to you.

DeVilbiss Air Power Company

213 Industrial Drive • Jackson, TN 38301-9615 • Telephone: 1-800-888-2468 , Ext. 2 • FAX: 1-800-888-9036

Form: SP-100-E - 4/25/96

SAFETY GUIDELINES - DEFINITIONS

<p>This manual contains information that is important for you to know and understand. This information relates to protecting YOUR SAFETY and PREVENTING EQUIPMENT PROBLEMS. To help you recognize this information, we use symbols to the right. Please read the manual and pay attention to these sections.</p>	<div style="border: 1px solid black; padding: 2px; display: inline-block;">⚠ DANGER</div>	<div style="border: 1px solid black; padding: 2px; display: inline-block;">⚠ CAUTION</div>
	<p>URGENT SAFETY INFORMATION - A HAZARD THAT WILL CAUSE SERIOUS INJURY OR LOSS OF LIFE.</p>	<p>Information for preventing damage to equipment.</p>
	<div style="border: 1px solid black; padding: 2px; display: inline-block;">⚠ WARNING</div>	<div style="border: 1px solid black; padding: 2px; display: inline-block;">NOTE</div>
	<p>IMPORTANT SAFETY INFORMATION - A HAZARD THAT <i>MIGHT</i> CAUSE SERIOUS INJURY OR LOSS OF LIFE.</p>	<p>Information that you should pay special attention to.</p>

IMPORTANT SAFETY INSTRUCTIONS

- SAVE THESE INSTRUCTIONS •



⚠ WARNING

IMPROPER OPERATION OR MAINTENANCE OF THIS PRODUCT COULD RESULT IN SERIOUS INJURY AND PROPERTY DAMAGE. READ AND UNDERSTAND ALL WARNINGS AND OPERATING INSTRUCTIONS BEFORE USING THIS EQUIPMENT.

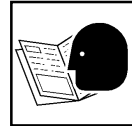

Risk of explosion.



HAZARD TO LOOK FOR	WHAT COULD HAPPEN	HOW TO PREVENT IT
<p><i>Compressed Gas</i></p>	<p>Oxygen will react with oil in tool causing an explosion. Flammable gases will ignite from sparking and cause the tool to explode.</p>	<p>Do not use any type of flammable gases or oxygen as a power source for the tool.</p> <p>Use only filtered, lubricated, regulated compressed air .</p>
<p><i>Excessive Operating Pressure</i></p>	<p>THE TOOL COULD EXPLODE!</p>	<p>Operate tool with clean, dry air regulated to 100 psi pressure maximum.</p>
<p><i>Unsuitable Cleaning Solvents</i></p>	<p>Flammable vapors in the tool will ignite by a spark and could cause the tool to explode!</p>	<p>Never use gasoline or other flammable liquids to clean the tool.</p> <p>Use non-flammable cleaning or degreasing materials.</p>

SAFETY GUIDELINES

⚠ DANGER



Read these warnings carefully. Failure to follow warnings will result in severe injury or death!

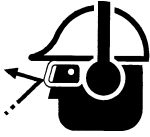

Risk of head injury.



HAZARD TO LOOK FOR	WHAT COULD HAPPEN	HOW TO PREVENT IT
<i>Injury to eyes, head and hearing</i>	Metal fragments, fasteners, or other material could be projected against head or into eyes. Continued exposure to an operating tool can result in permanent hearing damage.	Always wear ANSI approved Z87 safety glasses, Z89.1 head protection and S3.19 hearing protection.



Risk of puncture injury.

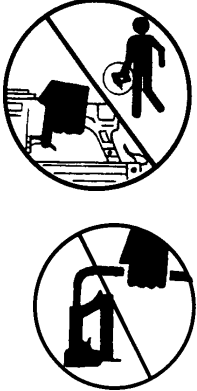

HAZARD TO LOOK FOR	WHAT COULD HAPPEN	HOW TO PREVENT IT
<p><i>Unsafe operation and improper handling of tool.</i></p> 	<p>A fastener could accidentally be driven if the contact trip safety mechanism is not working.</p> <p>Damage to the tool or to the contact trip safety mechanism can result from improper handling, resulting in unsafe operation.</p> <p>Death or a serious puncture would occur if the contact trip bumps something or someone while holding the tool with the trigger depressed.</p>	<p>Do not remove, modify or defeat contact safety device.</p> <p>Do not use the tool if any shields or guards are removed or altered.</p> <p>Always check contact trip safety mechanism of the tool before each use.</p> <p>Never carry the tool by the hose or pull the hose to move the tool or a compressor. Keep hoses away from heat, oil and sharp edges. Replace any damaged, weak or worn hoses.</p>

CONTINUED NEXT PAGE

SAFETY GUIDELINES



Risk of puncture injury.

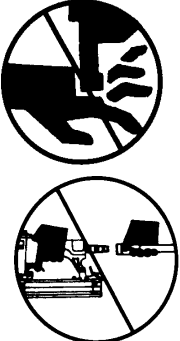

HAZARD TO LOOK FOR	WHAT COULD HAPPEN	HOW TO PREVENT IT
<p><i>Connecting and Disconnecting Air Hose</i></p> 	<p>Accidental discharge of a fastener can occur.</p>	<p>Hold tool by the handle and keep trigger and contact trip safety mechanism from contacting objects or parts of the body when connecting or disconnecting air supply.</p> <p>Disconnect air hose before loading fasteners, removing a jammed fastener, servicing the tool, or moving the tool to another work area.</p> <p>Do not use a check valve or any other fitting which allows air to remain in the tool.</p>



Risk from flying objects.

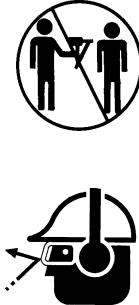

HAZARD TO LOOK FOR	WHAT COULD HAPPEN	HOW TO PREVENT IT
<p><i>Injury to self or others in the work area.</i></p> 	<p>Fasteners could ricochet or be propelled causing injury to self or others.</p> <p>When working along edges or next to voids in work surface, the contact trip safety mechanism could be depressed and allow the tool to discharge a fastener into the air or through thin work materials.</p>	<p>Pay attention to others in the work area to assure that they are protected from possible accidental discharge of fastener, or projected fragments of work material, fasteners, etc.</p> <p>Provide ANSI approved Z87 safety glasses, Z89.1 head protection, and S3.19 hearing protection to self and others in the work area.</p> <p>Never point discharge of tool at self or others.</p> <p>Do not pull trigger unless tool contact safety device is against work surface.</p> <p>Never attempt to drive fasteners into hard surfaces such as steel, concrete, or tile.</p> <p>Take care to avoid driving a fastener on top of another fastener.</p> <p>Before operating tool, be certain that work surfaces are strong enough and thick enough to contain entire fastener.</p> <p>Position tool carefully so that fasteners will be delivered to the proper location.</p>

LUBRICATION AND MAINTENANCE

⚠ CAUTION

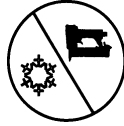

Do not store the tool in cold weather. Frost or ice can form on the operating valves or mechanisms and the tool may not operate correctly.

⚠ CAUTION



In cold weather operation (near or below freezing), DO NOT USE a permanent antifreeze such as ethylene glycol for a cold weather lubricant. This type of antifreeze will damage o-rings and seals of the tool.

NOTE

Proper lubrication is the owner's responsibility. Failure to lubricate the tool properly will dramatically shorten the life of the tool and void your warranty.

⚠ CAUTION

Your tool requires lubrication before you use it for the first time and before and after each additional use. If an **Oiler** is used, manual lubrication through the air inlet is not required on a daily basis. Lubrication prevents wear and prevents rust from forming.

1. Disconnect the air supply from the tool before manually lubricating.
2. Turn the tool so the air inlet is facing up and put **one drop** of DeVilbiss DV1719-01 Air Tool Oil, high speed spindle oil, such as Unocal RX22, or 3-in-1 oil into the air inlet. DO NOT USE detergent oil or additives. Operate the tool briefly after adding oil. (See Figure 1)

DONOT OVER LUBRICATE AIR TOOL.

3. Wipe off excessive oil at the exhaust.

NOTE

Many air tool users find it convenient to use an **Oiler** to help provide oil circulation through tool. An **Oiler** also increases the efficiency and useful life of the tool. An oiler is recommended for tools that receive heavy or constant use. Check oil level in the oiler daily. (See Figure 2)

Many air tool users find it convenient to use a **Filter** to remove liquid and solid impurities which can rust or "gum up" internal parts of the tool. A **Filter** also increases the efficiency and useful life of the tool. Drain water from the filter periodically. (See Figure 3)

Figure 1

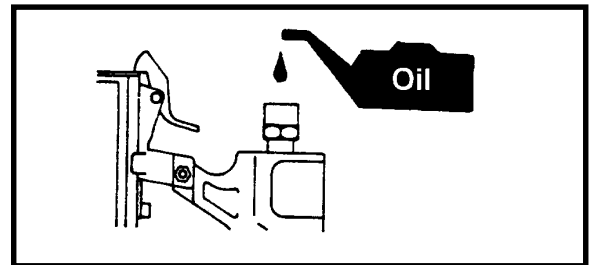

Figure 2

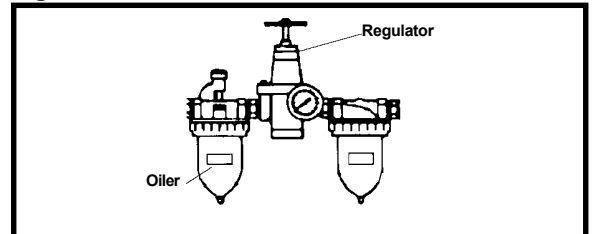
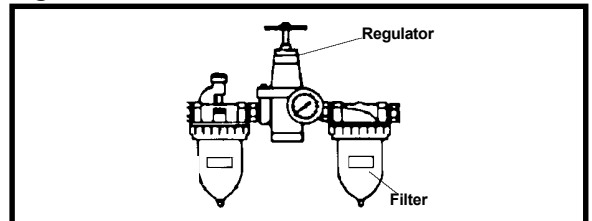

Figure 3



NOTE

Excessive oil will damage o-rings and seal of tool. If in-line oiler is used, manual lubrication through the air inlet is not required on a daily basis.

LUBRICATION AND MAINTENANCE

⚠ DANGER

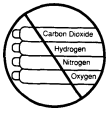

Do not use any type of flammable gases or oxygen as a power source for the tool. Use filtered, lubricated, regulated compressed air only. Use of compressed gas instead of compressed air may cause the tool to explode and cause death or serious personal injury.

⚠ WARNING

Do not use a check valve or any other fittings which will allow air to remain in the tool. Serious personal injury could occur.

⚠ WARNING

Use a **Pressure Regulator** on your compressor with an operating pressure of 0-125 PSI. A **Pressure Regulator** is required to control the operating pressure of your tool. (See Figure 4)

⚠ WARNING

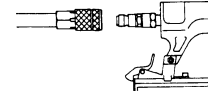
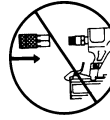

Always connect the Female Quick Coupler to the air hose. **Never** connect the Female Quick Coupler to the tool.

⚠ WARNING



Never carry the tool by the hose or pull the hose to move the tool or a compressor. Keep hoses away from heat, oil, and sharp edges. Replace any damaged, weak or worn hoses.

The air compressor must be able to maintain a minimum of 65 PSI when the tool is being used. An **inadequate** air supply can cause a loss of power or inconsistent operation.

Figure 4

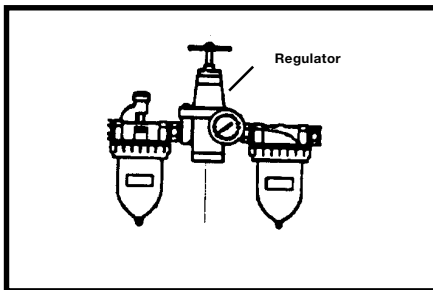

NOTE

For better performance, install a 3/8" Quick Connector (1/4" NPT threads) with an inside diameter of .315 (8 mm) on your Tool and a 3/8" Quick Coupler on the air hose. A minimum of 3/8" I.D. air hose with a rated working pressure of 150 PSI or above should be used.

RECOMMENDED HOOK-UP

The following illustration shows the proper hook-up which will help prolong the life of the Tool.

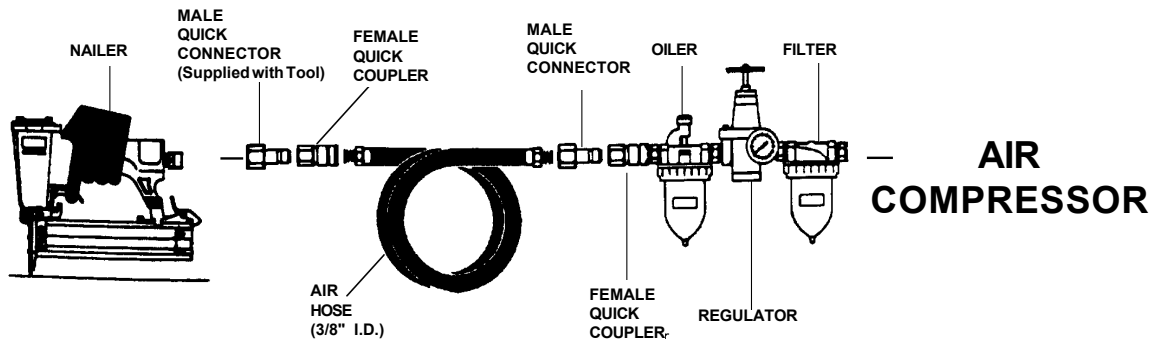

CONTACT TRIP SAFETY MECHANISM

⚠ DANGER



Never keep the trigger pulled on contact trip tools when carrying or holding the tool. Death or a serious puncture wound could occur if the contact trip bumps something or someone.

⚠ WARNING



Keep your hands and body away from the fastener discharge area of the tool. Serious personal injury could occur.

⚠ CAUTION

Do not hold the tool against the work surface with extra force. Allow the tool to drive the fastener.

⚠ WARNING

Do not use the contact trip mechanism as a means of discharging a fastener because:

1. It could result in personal injury
2. It could result in an accidental release of a fastener.
3. It may cause damage to the mechanism.
4. It could result in improper placement of fastener in work piece.

CONTACT TRIP

Your **FN7 Finishing Nailer** is a contact trip operated tool. When the operator depresses the contact trip safety mechanism against the work surface and then pulls the trigger, a fastener will be driven.

OPERATING A CONTACT TRIP TOOL:

1. Requires finger to be off the trigger and the nose of the tool to be placed on the work surface.
2. The contact trip safety mechanism is then depressed against the work surface and the trigger is pulled to drive a fastener.

3. The trigger is released after each fastener is driven.
4. Move the tool to the next desired fastener location and repeat the procedure above.

CHECKING THE OPERATION OF CONTACT TRIP SAFETY MECHANISM

⚠ CAUTION

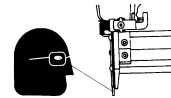

Check the operation of the contact trip safety mechanism often. Do not use the tool if the contact trip safety mechanism is not working correctly.

1. Disconnect the air supply from the tool.
2. Remove all fasteners from the magazine.
3. Make sure the trigger and contact trip safety mechanism move up and down without any sticking or binding.

⚠ DANGER



Make sure not to pull the trigger or depress the contact trip safety mechanism when connecting the tool to an air compressor. Serious personal injury can occur if the tool cycles.

4. Reconnect air supply to the tool.
5. Depress the contact trip safety mechanism against the work surface without pulling the trigger. The tool must not cycle. Do not use the tool if a cycle occurs.
6. Hold the tool clear of the work surface. The contact trip safety mechanism should return to its original down position. Pull the trigger. The tool **must not** cycle. Do not use the tool if a cycle occurs.
7. Depress the contact trip safety mechanism against the work surface. Pull the trigger. The tool **must** cycle.

LOADING THE TOOL

⚠ WARNING

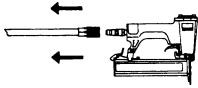

Disconnect tool from air supply before adjusting, clearing jams, servicing, relocating and during non-operation.

⚠ WARNING



Never place your hand, or any part of your body, in the fastener discharge area of the tool when air supply is connected to the tool. Serious personal injury may occur.

NOTE

Use DeVilbiss Air Power fasteners or equivalent for proper performance of tool. See page 15 for fastener information.

⚠ WARNING



Handle the tool carefully. Respect the tool as a working implement and always assume the tool contains fasteners and is ready to operate.

- Never use the tool as a toy and engage in horse-play.
- Never aim or point the tool at anyone. The tool may contain fasteners.
- Always keep people and animals at a safe distance from the work area in case of accidental discharge of fasteners.
- Never pull the trigger unless the nose of the tool is **against** the work surface.
- Do not pull the trigger or depress the contact trip when loading the Tool.

- Disconnect air hose.
- Pull up on the Stopper #54. Pull back on Reel Plate #40 to open magazine. (Items 40 & 54 - Page 13)
- Insert a stick of fasteners into the magazine. Make sure the pointed ends of the fasteners are resting on the bottom edge of the magazine. Also make sure fasteners are not dirty or damaged. Use DeVilbiss fasteners or equivalent for proper fastener performance.
- Push the magazine cover forward until the reel plate catches under stopper.

OPERATING THE TOOL

READ THIS MANUAL AND UNDERSTAND ALL SAFETY WARNINGS AND INSTRUCTIONS BEFORE OPERATING TOOL.

⚠ WARNING



Protect your eyes and ears. Wear Z87 safety glasses with side shields. Wear hearing protection. Employers and users are responsible for ensuring the user or anyone near the tool wear this safety protection.

⚠ WARNING

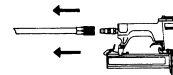

Disconnect tool from air supply before adjusting, clearing jams, servicing, loading, relocating and during non-operation.

NOTE

Check and replace any damaged or worn components on the tool. The safety warning labels on the tool must also be replaced if they are not legible.

OPERATING THE TOOL

1. Add one drop of DeVilbiss DV1719-01 Air Tool Oil, high speed spindle oil such as Unocal RX22, or 3-in-1 oil into the air inlet.
2. Attach a Quick Connect Fitting to the tool.
3. Connect the Tool to an air compressor using a 3/8" I.D. hose. **(The magazine must be empty of all fasteners)**. Make sure the hose has a rated working pressure exceeding 150 PSI and a Female Quick Coupler.
4. Regulate the air pressure to obtain 65 PSI at the tool. Check the operation of the Contact trip safety mechanism following the instructions in this manual.
5. Load fasteners into your tool following the instruction in this manual.
6. Reconnect the air hose to the tool.
7. Test for proper fastener penetration by driving fasteners into a sample piece of material. If the fasteners do not achieve the desired penetration, adjust the air pressure to a lower or higher setting until the desired penetration is achieved. Do not exceed 100 psi at the tool.

CLEARING A JAM FROM THE TOOL



FASTENER JAM INSIDE MAGAZINE:

1. Disconnect tool from air hose.
2. Pull up on #54 Stopper. Pull back on #40 Reel Plate to open magazine. (Items #40 and #54 on page 13)
3. Remove jammed fastener from magazine.
4. Push Reel Plate forward until catch under stopper.

FASTENER JAMMED IN FASTENER DISCHARGE AREA:

1. Disconnect tool from air hose.
2. Pull up on Stopper #54 Pull back on Reel Plate #40 to open magazine. (Items #40 and #54 on page 13)
3. Remove fasteners in magazine.
4. Remove 2 screws from nose door.
5. Remove nose door.
6. Grab jammed fastener with pliers and remove. **(See Figure 5)**
7. Reposition nose door and secure with 2 screws.
8. Reload fasteners.
9. Push Reel Plate forward until catches under stopper.

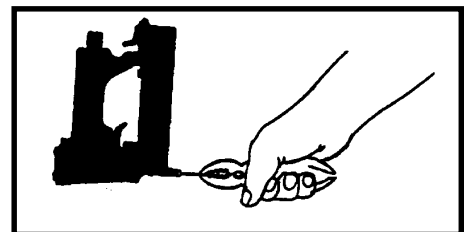

Figure 5

TROUBLESHOOTING GUIDE

⚠ WARNING

Stop using the Tool immediately if any of the following occur. Serious personal injury could occur. Warranty repairs or replacements must be performed by a DeVilbiss Air Power Authorized Service Center Only.

PROBLEM	CAUSE	SOLUTION
<i>Air leaking at trigger valve area.</i>	Seals in trigger shaft valve housing are damaged. Trigger shaft valve spring worn.	Seals must be replaced. (NSK-023) Replace valve spring. (NSK-023)
<i>Air leaking between housing and exhaust deflector</i>	Loose exhaust deflector screws. Damaged cylinder top seal. Damaged cap seals. Cap spring weak or damaged.	Screws need to be tightened. Seals need to be replaced. (NSK-020) Seals needs to be replaced. (NSK-020) Replace cap spring. (NSK-020)
<i>Tool fails to drive fastener.</i>	Worn or damaged joint guide. Driver blade damaged. Dirt between guide body and door. Dirt or damage prevents fasteners or fastener pusher from moving freely in magazine. Damaged fastener pusher spring. Inadequate air flow or pressure to tool. Worn seal on piston or lack of lubrication. Damaged seal on trigger shaft valve. Cylinder sleeve seals damaged. Cap seal leaking. Tool not lubricated sufficiently.	Joint guide needs to be replaced. (NSK-021) Replace driver blade. (NSK-021) Clean. Magazine needs to be cleaned or repaired. Spring needs to be replaced. Verify air pressure to tool. Seal need to be replaced. Lubricate. (NSK-021) Seal needs to be replaced or lubricated. (NSK-023) Replace seals. (NSK-022) Seal needs to be replaced. (NSK-020) Tool needs to be lubricated.
<i>Tool runs slow or has loss of power.</i>	Inadequate air flow or pressure to tool. Broken spring in cylinder cap. Worn seal on piston or lack of lubrication. Exhaust port in cap is blocked.	Verify air pressure to tool. Replace spring. (NSK-020) Replace seal (NSK-021) lubricate. Inspect and clear blockage.
<i>Fasteners are jammed in tool.</i>	Driver blade is worn or damaged Fasteners are not correct size. Fasteners are bent. Fasteners coming apart in magazine. Latch assembly weak or damaged. Guide body groove damaged. Door groove damaged. Fasteners pusher system defective.	Replace driver blade. (NSK-021) Fasteners recommended for tool must be used. Replace with undamaged fasteners. Verify and replace. Replace latch assembly. Repace guide body. Replace door. Determine defective part and replace.

EXPLODED VIEW

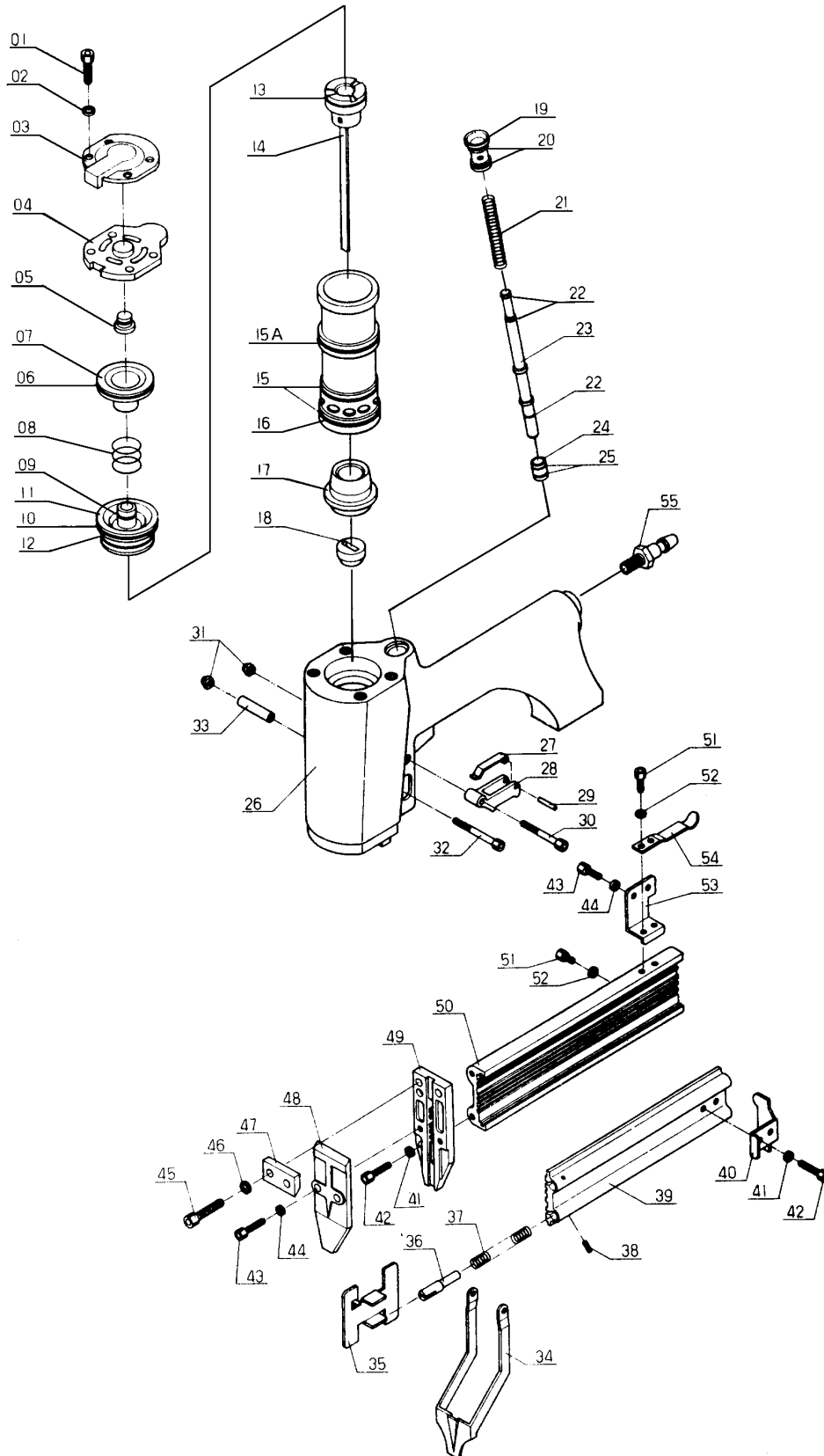

PARTS LIST

KEY NO.	PART NUMBER	DESCRIPTION	KEY NO.	PART NUMBER	DESCRIPTION
1	NSP-359	Screw	28	NSP-128	Trigger
2	NSP-360	Washer	29	NSP-129	Pin
3	NSP-361	Exhaust Deflector	30	NSP-379	Screw
4	NSP-362	Cylinder Cap Assy.	31		Nut
* 5	NSP-363	Insert of Cap	32	NSP-005	Screw
* 6	-----	Seal	33	NSP-380	Spacer Sleeve
7	NSP-365	Cap Insert	34	NSP-381	Safety
8	NSP-366	Spring	35	NSP-382	Pusher
* 9	-----	Seal	36	NSP-383	Pusher
* 10	-----	Seal	37	NSP-384	Spring
11	NSP-369	Gasket Set	38	NSP-385	Pin
* 12	-----	Seal	39	NSP-386	Magazine unit B
+ 13	-----	Seal	40	NSP-387	Real Plate
+ 14	-----	Drive Blade with Piston	41	NSP-388	Washer
# 15	-----	Seal	42	NSP-389	Screw
# 15A	----	Seal	43	NSP-390	Screw
16	NSP-374	Cylinder Sleeve Assy.	44	NSP-391	Washer
# 17	-----	Piston Stop	45	NSP-392	Screw
# 18	-----	Joint Guide	46	NSP-393	Washer
19	NSP-121	Collar	47	NSP-394	Plate
\ 20	-----	Seal	48	NSP-395	Door
\ 21	-----	Spring	49	NSP-396	Guide Body
\ 22	-----	Seal	50	NSP-397	Magazine Unit A
23	NSP-002	Shaft, Valve	51	NSP-398	Screw
24	NSP-126	Copper Cover	52	NSP-399	Washer
\ 25	-----	Seal	53	NSP-400	Plate, Attaching
26	NSP-377	Main Body Assy.	54	NSP-401	Stopper
27	NSP-378	Inner Trigger	55	NSP-402	Air Plug

PART KITS

* Key Numbers 5, 6, 9, 10, and 12 can only be purchased as part of NSK-020 Top Repair Kit.

+ Key Numbers 13, and 14 can only be purchased as part of NSK-021 Driver Blade Kit.

Key Numbers 15, 15A, 17, and 18 can only be purchased as part of NSK-022 Bottom Repair Kit.

\ Key Numbers 20, 21, 22, and 25 can only be purchased as part of NSK-023 Trigger Repair Kit.

FASTENERS

Fastener Part #	Length	Shank Gauge	Shank Type	Crown or Head Type	Collation	Finish	QTY Per Box
7T25	1"	16 GA	-	Finish	Adhesive	Galvanized	2,500
7T32	1 1/4"	16 GA	-	Finish	Adhesive	Galvanized	2,500
7T38	1 1/2"	16 GA	-	Finish	Adhesive	Galvanized	2,500
7T45	1 3/4"	16 GA	-	Finish	Adhesive	Galvanized	2,500
7T50	2"	16 GA	-	Finish	Adhesive	Galvanized	2,500

INTERCHANGE INFORMATION

The DeVilbiss Finishing Nailer FN7, will accept Fasteners for:

**Bostitch
Senco
Duofast
Paslode**

**Fasco
Atro
BEA
Haubold**

These Fasteners should be the same length and shank gauge as the DeVilbiss Fasteners.

DeVILBISS AIR POWER COMPANY

STEEL DRIVERS SERIES

Operating, Maintenance and Parts

Manual for **FN7**

Finishing Nailer

Retain the original sales receipts as proof of purchase for warranty repair work.

Attach sales receipt here.

Call our **Toll Free Number 1-800-888-2468, Ext 2, then 1**, to obtain the location of the nearest Authorized Service Center for ordering repair parts and for warranty repairs.

When ordering repair parts from your local Authorized Service Center, always give the following information:

- Model number of your product
- Part number and description of the item you wish to purchase

WARRANTY

This product is covered by the DeVilbiss one year limited warranty. The warranty can be found on page 3 or is available upon request.