

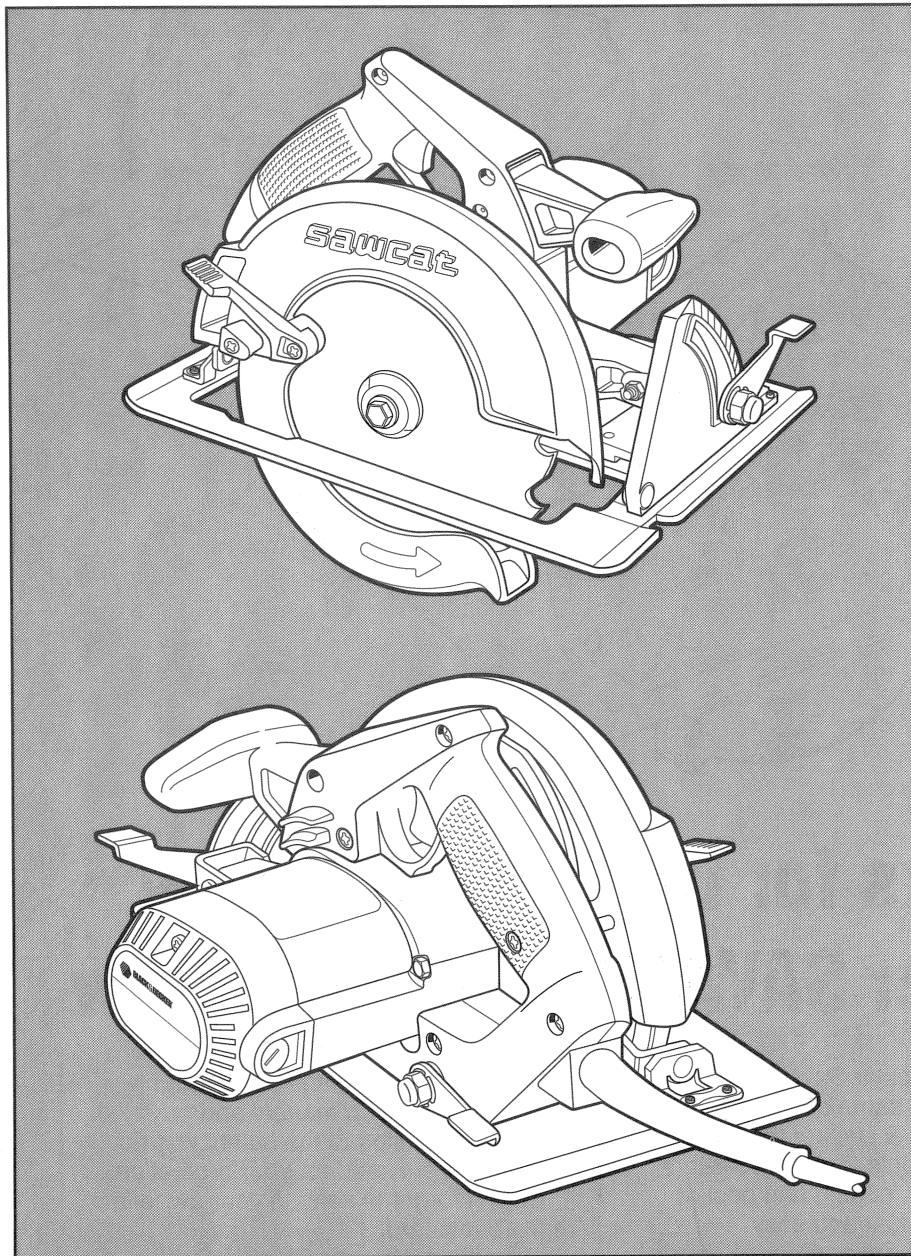

BLACK&DECKER®



Instruction Manual

SAWCAT® Circular Saws

**3057 (7-1/4"), 3059 (7-1/4"),
2683 (7-1/4"), 2686 (8-1/4")**

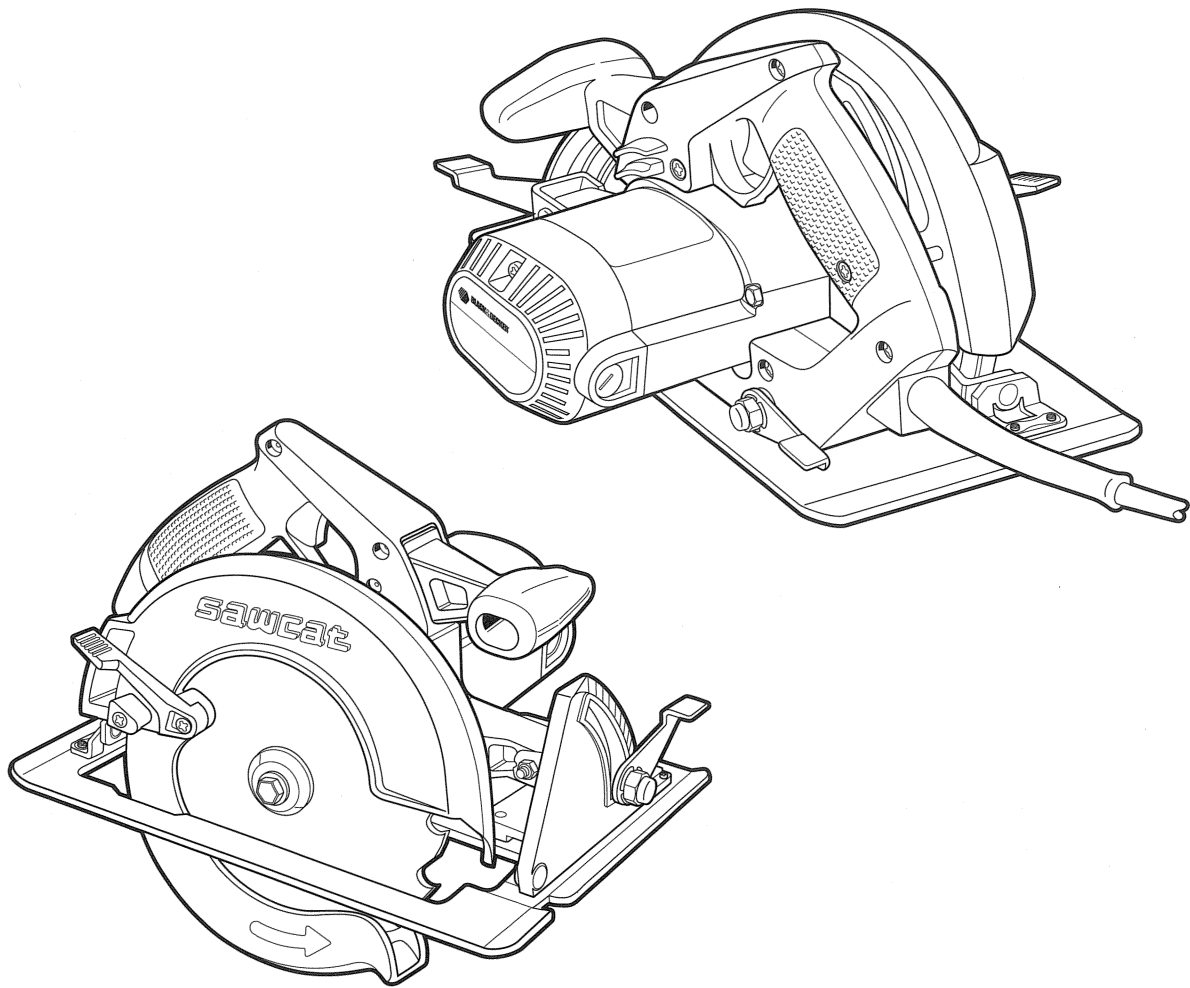

Thanks for Buying a Black & Decker SAWCAT® Circular Saw

Your new Circular Saw is designed and built to those same standards that have made Black & Decker the world leader in power tools for over 75 years.

Cross-cutting, ripping and pocket cutting are made fast and easy.

We know you will appreciate your saw and the more you know about it the happier you'll be.

Please take the time to thoroughly read this instruction manual and pay particular attention to the safety instructions we've provided for your protection.

Don't forget to send in your owner's registration card.

Thanks for buying Black & Decker.



BLACK & DECKER®

Important Safety Instructions (For All Tools)

WARNING: When using Electric Tools, basic safety precautions should always be followed to reduce risk of fire, electric shock, and personal injury, including the following:

READ ALL INSTRUCTIONS

1. **KEEP WORK AREA CLEAN.** Cluttered areas and benches invite injuries.
2. **CONSIDER WORK AREA ENVIRONMENT.** Don't expose power tools to rain. Don't use power tools in damp or wet locations. Keep work area well lit.
3. **GUARD AGAINST ELECTRIC SHOCK.** Prevent body contact with grounded surfaces. For example: pipes, radiators, ranges, refrigerator enclosures.
4. **KEEP CHILDREN AWAY.** All visitors should be kept away from work area. Do not let visitors contact tool or extension cord.
5. **STORE IDLE TOOLS.** When not in use, tools should be stored in dry, and high or locked-up place - out of reach of children.
6. **DON'T FORCE TOOL.** It will do the job better and safer at the rate for which it was intended.
7. **USE RIGHT TOOL.** Don't force small tool or attachment to do the job of a heavy-duty tool. Don't use tool for purpose not intended, for example, don't use circular saw for cutting tree limbs or logs.
8. **DRESS PROPERLY.** Do not wear loose clothing or jewelry. They can be caught in moving parts. rubber gloves and non-skid footwear are recommended when working outdoors. Wear protective hair covering to contain long hair.
9. **USE SAFETY GLASSES.** Also use face or dustmask if cutting operation is dusty.
10. **DON'T ABUSE CORD.** Never carry tool by cord or yank it to disconnect from receptacle. Keep cord from heat, oil, and sharp edges.
11. **SECURE WORK.** Use clamps or a vise to hold work. It's safer than using your hand and it frees both hands to operate tool.
12. **DON'T OVERREACH.** Keep proper footing and balance at all times.
13. **MAINTAIN TOOLS WITH CARE.** Keep tools sharp and clean for better and safe performance. Follow instructions for lubricating and changing accessories. Inspect tool cords periodically and if damaged have repaired by authorized service facility. Inspect extension cords periodically and replace if damaged. Keep handles dry, clean, and free from oil and grease.
14. **DISCONNECT TOOLS.** When not in use, before servicing, and when changing accessories, such as blades, bits, cutters.
15. **REMOVE ADJUSTING KEYS AND WRENCHES.** Form habit of checking to see that keys and adjusting wrenches are removed from tool before turning it on.
16. **AVOID UNINTENTIONAL STARTING.** Don't carry plugged-in tool with finger on switch. Be sure switch is off when plugging in.
17. **OUTDOOR USE EXTENSION CORDS.** When tool is used outdoors, use only extension cords intended for use outdoors and so marked.
18. **STAY ALERT.** Watch what you are doing. Use common sense. Do not operate tool when you are tired.
19. **CHECK DAMAGED PARTS.** Before further use of the tool, a guard or other part that is damaged should be carefully checked to determine that it will operate properly and perform its intended function. Check for alignment of moving parts, binding of moving parts, breakage of parts, mounting, and any other conditions that may affect its operation. A guard or other part that is defective should be properly repaired or replaced by an authorized service center unless otherwise indicated elsewhere in this instruction manual. Have defective switches replaced by authorized service center. Do not use tool if switch does not turn it on and off.
20. **DO NOT OPERATE** portable electric tools near flammable liquids or in gaseous or explosive atmospheres. Motors in these tools normally spark, and the sparks might ignite fumes.

SAVE THESE INSTRUCTIONS FOR FUTURE USE.

Additional Circular Saw Safety Instructions

1. Disconnect plug from power supply before changing blades, making cutting depth or bevel angle adjustments, inspecting, cleaning or when saw is not being used.
2. Keep guards in place and in working order. Never wedge or tie lower guard open. Check operation of lower guard before each use. Do not use if lower guard does not close briskly and completely over saw blade. **CAUTION:** If saw is dropped, lower guard may be bent restricting full return. Do not use saw until the lower guard is returned to the proper working order.
3. **KEEP BLADES CLEAN AND SHARP.** Sharp blades minimize stalling overload, kickback and give a cleaner cut.
4. **DANGER: KEEP HANDS AWAY FROM CUTTING AREA.** Keep hands away from blades. Do not reach underneath work while blade is rotating. Do not attempt to remove cut material when blade is moving. **CAUTION:** Blades continue to coast after releasing trigger. Never place your hand on the work surface in front of or behind the saw.
5. **SUPPORT LARGE PANELS.** Large panels must be supported as shown in FIGURE 16 to minimize the risk of overload and kickback from blade pinching. When cutting operation requires the resting of the saw on the workpiece, the saw should be rested on the larger portion and the smaller piece cut off.
6. **USE RIP FENCE.** Always use a fence or straight edge guide when ripping.
7. **GUARD AGAINST KICKBACK.** Kickback occurs when the saw begins to stall rapidly and is driven back towards the operator. Release switch immediately if blade binds or saw stalls. Keep blades sharp. Support large panels as shown in FIGURE 16. Use fence or straight edge guide when ripping. Don't force tool. Stay alert, exercise control. Don't remove saw from work during a cut while the blade is moving. A more detailed explanation of Kickback follows the "Operation" section of this manual.
8. **LOWER GUARD.** When necessary for accurate starts or when pocket cutting, raise lower guard with the retracting lever.
9. **ADJUSTMENTS.** Before cutting be sure depth and bevel adjustments are tight.
10. **USE ONLY BLADES WITH 5/8" ARBOR.** Do not use blades with incorrect size holes. Never use defective or incorrect blade washers or bolts.
11. **AVOID CUTTING NAILS.** Inspect for and remove all nails from lumber before cutting.

CAUTION: When sawing into walls, floors or wherever "live" electrical wires may be encountered, **DO NOT TOUCH ANY METAL PARTS OF THE TOOL!** Hold the Saw only by its plastic handles to prevent electric shock if you accidentally saw into a "live" wire.

SAVE THESE INSTRUCTIONS

Motor

Your Black & Decker tool is powered by a B&D-built motor. Be sure your power supply agrees with nameplate marking. 120 Volts AC/DC means your saw will operate on alternating or direct current. Lower voltage will cause loss of power and can result in over-heating. All B&D tools are factory-tested; if this tool does not operate, check the power supply.

Double Insulation (3057, 3059 ONLY)

Your unit is **DOUBLE INSULATED** to permit use on non-grounded circuits. This means that it is constructed throughout with **TWO** separate "layers" of electrical insulation or one **DOUBLE** thickness of insulation between you and the tool's electrical system.

Tools built with this insulation system are not intended to be grounded. As a result, your tool is equipped with a two-prong plug which permits you to use extension cords without concern for maintaining a ground connection.

NOTE: DOUBLE INSULATION

does not take the place of normal safety precautions when operating this tool. The insulation system is for added protection against injury resulting from a possible electrical insulation failure within the tool.

CAUTION: When servicing all tools, **USE ONLY IDENTICAL REPLACEMENT PARTS.** Repair or replace damaged cords.

Grounding (2683, 2686 ONLY)

This tool should be grounded while in use to protect the operator from electric shock. The tool is equipped with an approved three-conductor cord and three prong grounding type plug to fit the proper grounding receptacle. The green (or green and yellow) conductor in the cord is the grounding wire. Never connect the green (or green and yellow) wire to a live terminal. If your unit is for use on less than 150 volts, it has a plug like that shown in Figure A. If it is for use on 150 to 250 volts, it has a plug like that shown in Figure D.

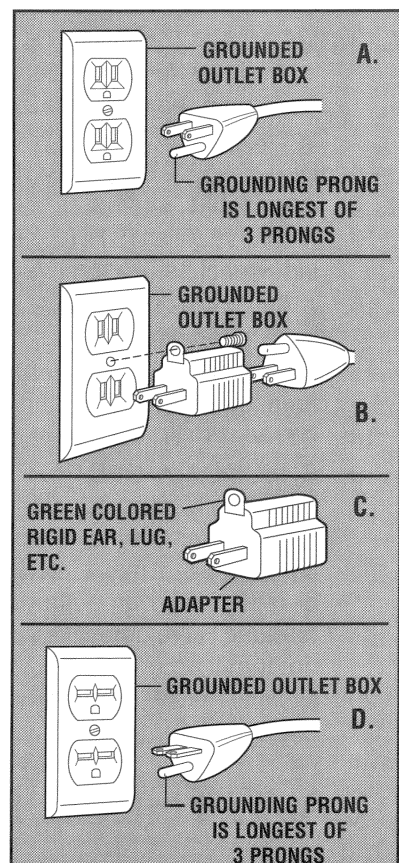

Check the tool's nameplate to determine the proper voltage. An adapter, Figures B and C, is available for connecting Figure A plugs to two-prong receptacles. The green-colored rigid ear, lug, etc., must be connected to a permanent ground such as a properly grounded outlet box. No adapter is available for a plug as shown in Figure D. ADAPTER SHOWN IN FIGURES B & C IS NOT FOR USE IN CANADA.

Brushes

DISCONNECT PLUG FROM POWER SUPPLY BEFORE SERVICING

Inspect carbon brushes regularly by unplugging tool, removing the Brush Inspection Cap (Fig. 2) and withdrawing the brush assembly. Keep brushes clean and sliding freely in their guides. Always replace a used brush in the same orientation in the holder as it was prior to removal. Carbon brushes have varying symbols stamped into their sides, and if the brush is worn down to the line closest to the spring, they must be replaced. Use only identical Black & Decker brushes. New brush assemblies are available at Black & Decker Service Centers. The tool should be allowed to "run in" (run at no load without a blade) for 10 minutes before use to seat new brushes.

While "running in" DO NOT TIE, TAPE, OR OTHERWISE LOCK THE TRIGGER SWITCH ON. HOLD BY HAND ONLY.

Adjustments and Setup

ATTACHING AND REMOVING BLADES

DISCONNECT PLUG FROM POWER SUPPLY.

To attach the blade, retract lower blade guard and place inner clamp washer and blade on saw spindle with printed side of blade out (teeth at bottom of blade pointing forward) (Fig. 1). The larger surfaces of both washers must face the blade. Thread on blade clamping screw firmly by hand to hold washer in position.

Lightly depress the blade lock (Fig. 2) while turning the spindle until the blade stops rotating. Tighten blade clamping screw (clockwise) firmly with the blade wrench (Fig. 3).

NEVER ENGAGE BLADE LOCK WHILE SAW IS RUNNING, OR ENGAGE IN AN EFFORT TO STOP THE TOOL. NEVER TURN SWITCH ON WHEN BLADE LOCK IS ENGAGED.

When removing the blade, first unplug the saw. Engage the blade lock and unscrew the blade clamping screw by turning it counter-clockwise with the blade wrench.

FIG. 2

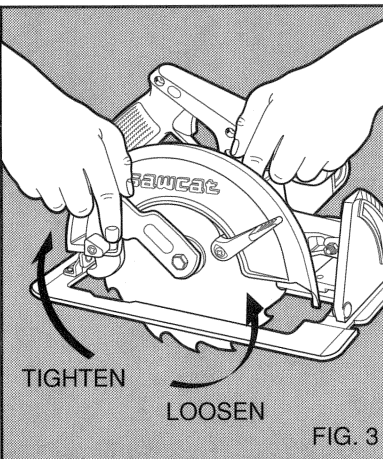
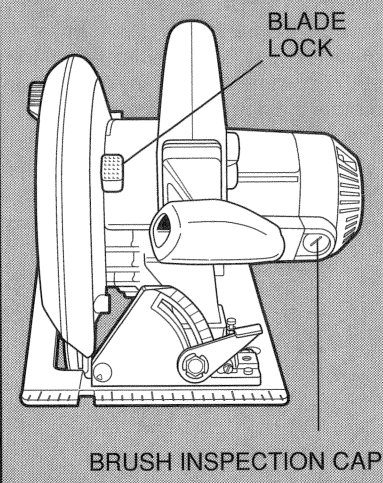
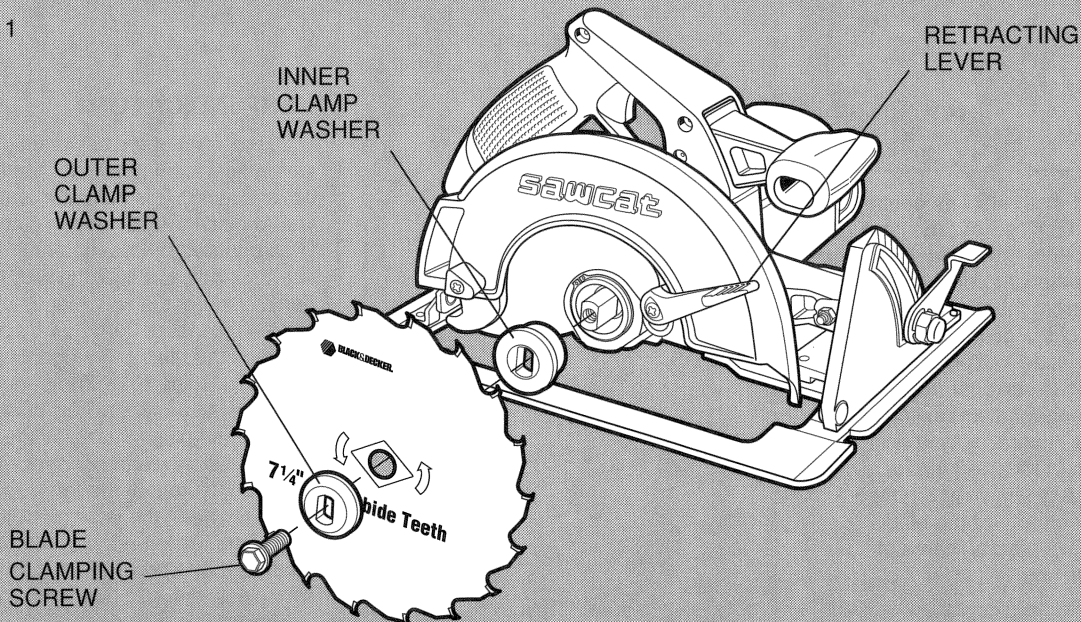

FIG. 1



CUTTING DEPTH ADJUSTMENT

DISCONNECT PLUG FROM POWER SUPPLY.

Hold the Saw firmly as shown in Figure 4. Loosen (counterclockwise) the Depth Adjustment Lever and move shoe to obtain the desired depth of cut, as shown in Figure 5. Make sure Depth Adjustment Lever has been retightened (clockwise) before operating saw.

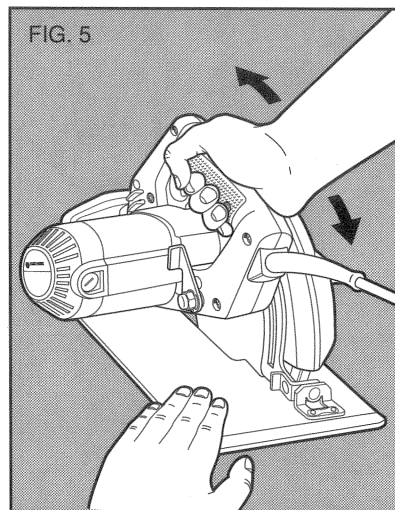
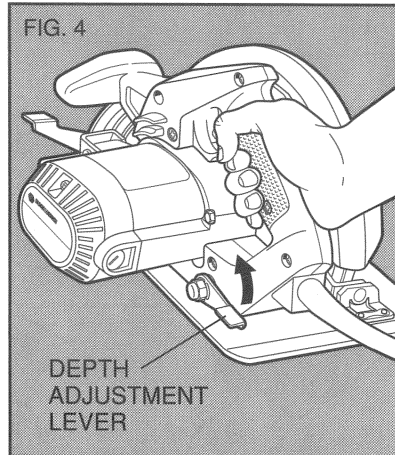

For the most efficient cutting action, set the Depth Adjustment so that one tooth of the blade will project below the material to be cut. This distance is from the tip of the tooth to the bottom of the gullet in front of it. This keeps blade friction at a minimum, removes sawdust from the cut, results in cooler, faster sawing and reduces the chance of kickback.

A method for checking for correct cutting depth is shown in Figure 6. Note that one tooth of the blade projects above a scrap piece of the lumber to be cut.

NOTE: When using Carbide-Tipped Blades, make an exception to the above rule and allow only one-half of a tooth to project above the material to be cut.

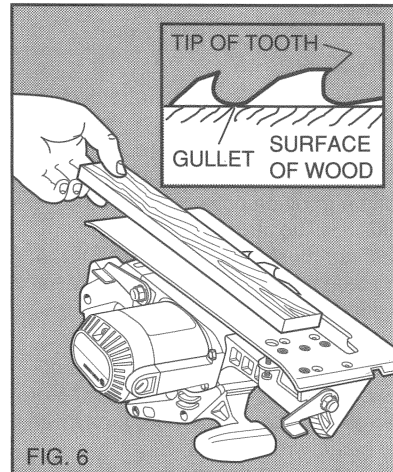

BEVEL ANGLE ADJUSTMENT

DISCONNECT THE SAW FROM THE POWER SUPPLY.

The full range of the Bevel Adjustment is from **0 TO 50 DEGREES**. The quadrant is graduated in increments of 5 degrees.

On the front of the saw is a bevel angle adjustment mechanism (Figure 8) consisting of calibrated quadrant and a lever. To set the saw for a bevel cut, loosen (counterclockwise) the quadrant lever and tilt shoe to the desired angle by aligning the pointer with the desired angle mark. Retighten lever firmly (clockwise).

Align the quadrant pointer with the desired mark on the quadrant. The quadrant pointer, located between the quadrant lever and the quadrant, can be adjusted after loosening its screw. Retighten firmly after adjustment.

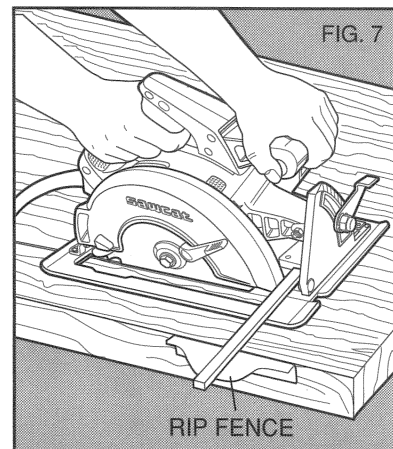

RETRACTING LEVER

CORD KEEPER
(Keeps cord away when cutting downward)

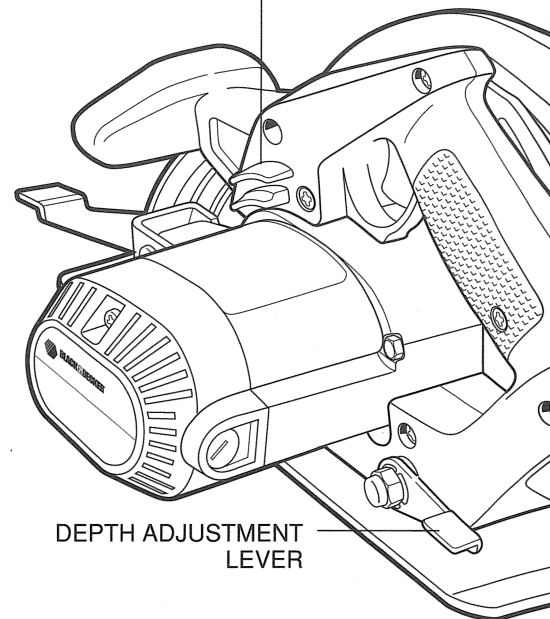

KERF INDICATOR

The front of the saw shoe has a kerf indicator (Figure 8) for vertical and bevel cutting. This indicator enables you to guide the saw along cutting lines penciled on the material being cut. The indicator lines up with the left (inner) side of the saw blade, which makes the slot or "kerf" cut by the moving blade fall to the right of the indicator. Guide along the penciled cutting line so that the kerf falls into the waste or surplus material - See Figure 9. Figure 9 shows the dimensions of the shoe. Note that the left side is 5 1/2" between the left side of the blade and the left edge of the shoe (standard 6x lumber). The right dimension is 1 1/2" (standard 2x lumber).

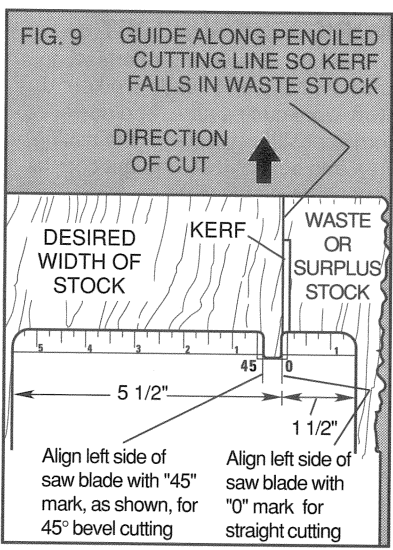
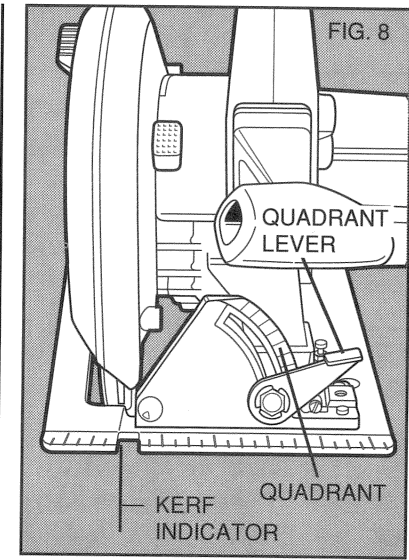
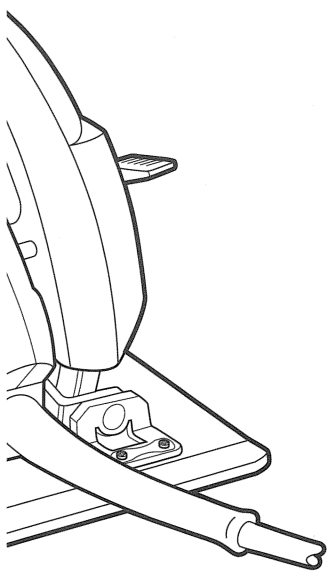
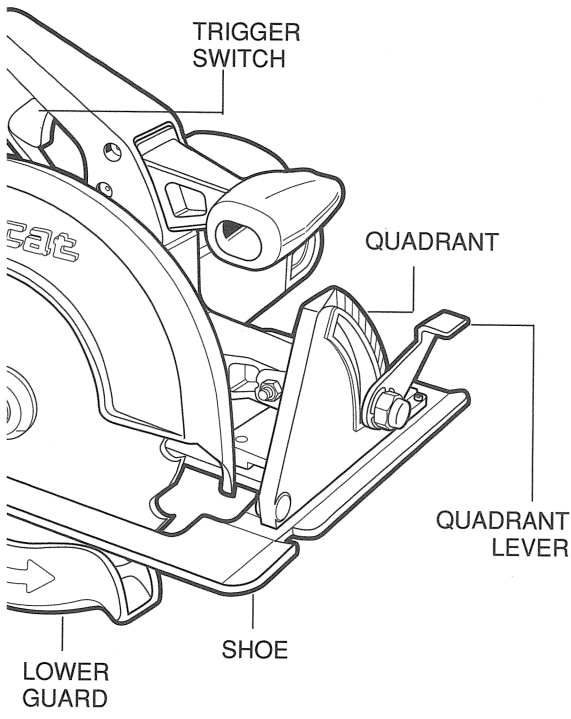

SHOE ALIGNMENT

Your saw has been set at the factory for accurate vertical cuts (a 90 degree angle between the bottom of the shoe and the blade). The edge of the shoe has also been set parallel to the blade so that it will not bind when using an edge guide. If the saw should ever need adjusting, it may be done as follows:

ADJUSTING FOR 90° CUTS

1. DISCONNECT PLUG FROM POWER SUPPLY.
2. Adjust the saw to 0° bevel.
3. Place saw on blade side (Fig. 10). Retract blade guard.
4. Loosen quadrant lever. Fig. 10. Place a square against the blade and shoe to adjust the 90° setting.

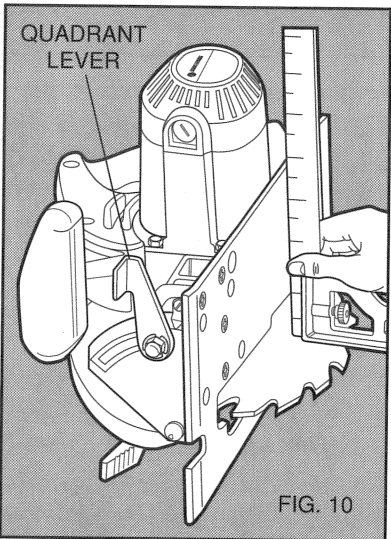

5. Loosen the hex nut and move the adjustment screw so that the shoe will stop at the proper angle as shown in Figure 11. Lock the screw in place by tightening the hex nut.

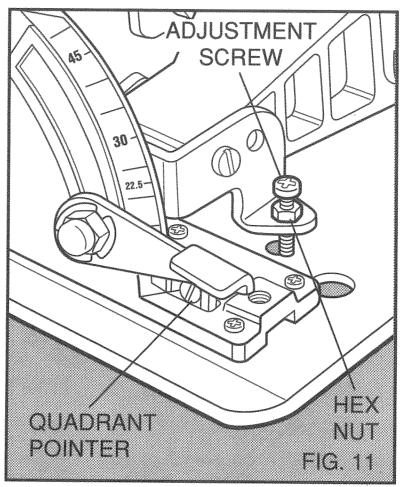

6. It may be necessary to adjust the quadrant angle pointer to line up on "0" after shoe has been adjusted.

ADJUSTING THE SHOE PARALLEL TO THE BLADE

1. DISCONNECT PLUG FROM POWER SUPPLY.
2. Loosen the (2) screws at the adjusting bracket at the rear of the shoe, as shown in Figure 12.
3. Adjust the shoe until it is parallel to the blade by measuring from the edge of the shoe to the blade, front & rear. You can measure from the outside edge of the blade to the shoe as shown in Figure 12 or from the inner edge of the blade to the wider part of the shoe. (Do not measure from the tips of any saw blade teeth.)
4. When shoe is parallel, tighten all screws.

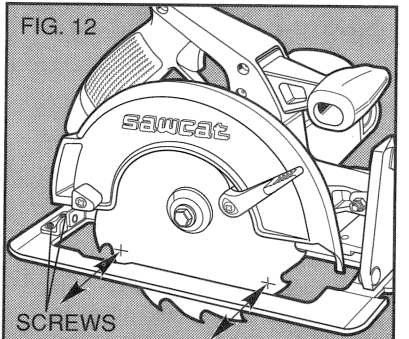

ADJUSTING DEPTH ADJUSTMENT & QUADRANT LEVERS

It may be desirable to adjust the Depth Adjustment and Quadrant adjustment levers. (They will sometimes hit the shoe before fully tightening or loosening completely.) To adjust either lever, follow the steps below.

1. DISCONNECT PLUG FROM POWER SUPPLY.
2. Using a small screwdriver, pry the lock ring off, as shown in Figure 13.

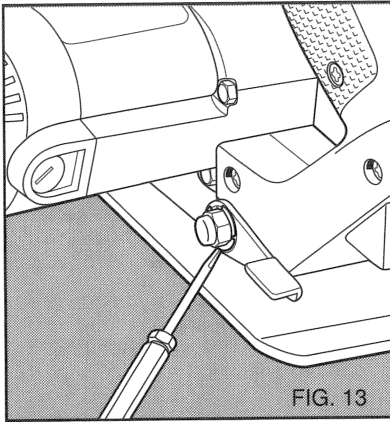

FIG. 13

3. Remove the lever and rotate it in the desired direction about 1/8 revolution. (More or less as necessary.)
4. Reinstall the lever and insert the lock ring to hold it in place.

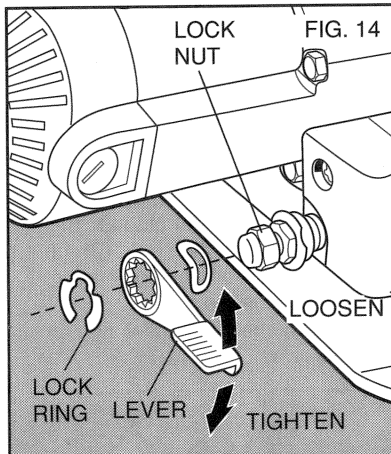

FIG. 14

Operation

SWITCH

Pull the trigger switch to turn the motor "ON". Releasing the trigger turns the motor "OFF". This tool has no provision to lock the switch in the "ON" position, and should never be locked "ON" by any other means.

WORKPIECE SUPPORT

Figure 15 shows proper sawing position. Note that hands are kept away from cutting area, and power cord is positioned clear of the cutting area and so that it will not get caught or hung up on the work.

To avoid kickback, DO support board or panel NEAR the cut, (Figure 16). DON'T support board or panel away from the cut, (Figure 17).

When operating the saw, keep the cord away from the cutting area and prevent it from becoming hung up on the work piece. Note that a special Cord Keeper has been provided on the tool's handle.

WARNING: It is important to support the work properly and to hold the saw firmly to prevent loss of control which could cause personal injury; Figure 18 illustrates typical hand support of the saw.

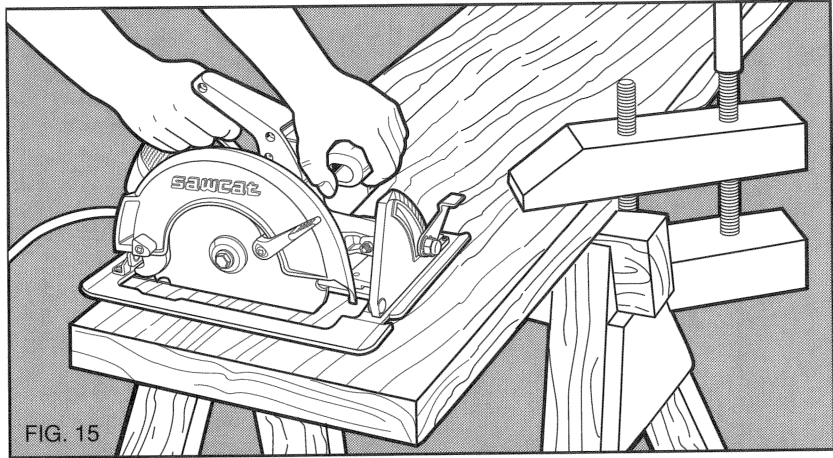
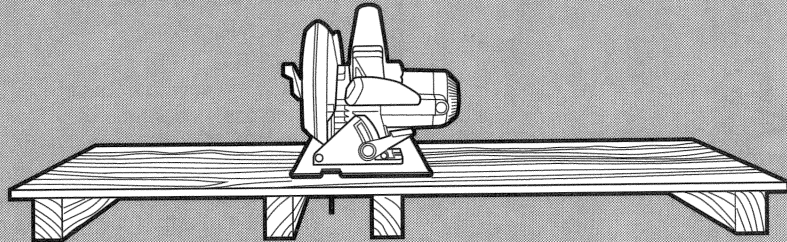

FIG. 15

FIG. 16

SUPPORT WORK NEAR CUT



RIGHT

FIG. 17

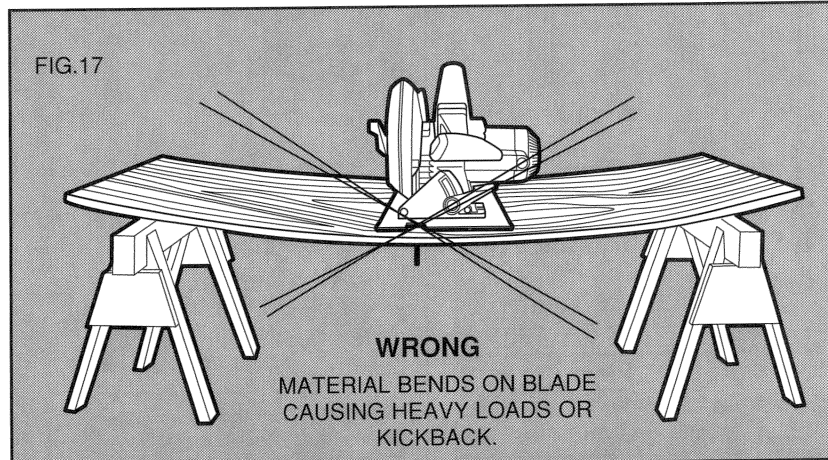

WRONG

MATERIAL BENDS ON BLADE
CAUSING HEAVY LOADS OR
KICKBACK.

ALWAYS DISCONNECT SAW BEFORE MAKING ANY ADJUSTMENTS! Place the work with its "good" side - the one on which appearance is most important - down. The saw cuts upward, so any splintering will be on the work face that is up when you saw it.

CUTTING

Support the work so that the cut will be on your right. Place the wider portion of the saw shoe on that part of the work piece which is solidly supported, not on the section that will fall off when the cut is made. As examples, Figure 18 illustrates the RIGHT way to cut off the end of a board, and Figure 19 the WRONG way. Always clamp work. Don't try to hold short pieces by hand! Remember to support cantilevered and overhanging material. Use caution when sawing material from below.

Be sure saw is up to full speed before blade contacts material to be cut. Starting saw with blade against material to be cut or pushed forward into kerf can result in kickback.

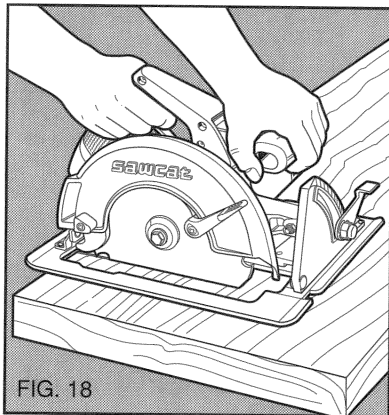
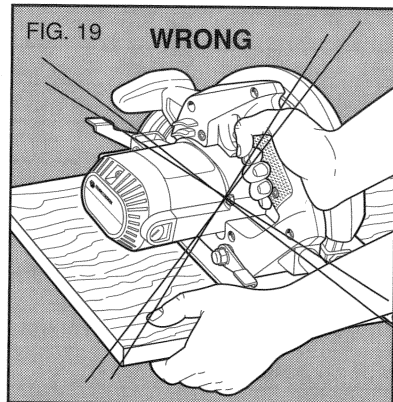

FIG. 18



Push the saw forward at a speed which allows the blade to cut without laboring. Hardness and toughness can

vary even in the same piece of material, and knotty or damp sections can put a heavy load on the saw. When this happens, push the saw more slowly, but hard enough to keep it working without much decrease in speed. Forcing the saw can cause rough cuts, inaccuracy, kickback and over-heating of the motor.

Should your cut begin to go off the line, don't try to force it back on. Release the switch and allow blade to come to a complete stop. Then you can withdraw the saw, sight anew, and start a new cut slightly inside the wrong one. In any event, withdraw the saw if you must shift the cut. Forcing a correction inside the cut can stall the saw and lead to kickback. IF SAW STALLS, RELEASE THE TRIGGER AND BACK THE SAW UNTIL IT IS LOOSE. BE SURE BLADE IS STRAIGHT IN THE CUT AND CLEAR OF THE CUTTING EDGE BEFORE RESTARTING.

As you finish a cut, release the trigger and allow the blade to stop before lifting the saw from the work. As you lift the saw, the spring-tensioned telescoping guard will automatically close under the blade. Remember the blade is exposed until this occurs, never reach under the work for any reason whatsoever. When you have to retract the telescoping guard manually (as is necessary for starting pocket cuts) always use the retracting lever.

NOTE: When cutting thin strips, be careful to ensure that small cutoff pieces don't hang up on inside of lower guard.

When ripping (cutting with the grain) the use of a rip fence is recommended. (See Figure 7)

POCKET CUTTING

DISCONNECT PLUG FROM POWER SUPPLY. Adjust saw shoe so blade cuts at desired depth. Tilt saw forward and rest front of the shoe on material to be cut. Using the retracting lever, retract blade guard to an upward position. Lower rear of shoe until blade teeth almost touch cutting line. Now release the blade guard (its contact with the work will keep it in position to open freely as you start the cut) (Figure 20). Start the motor and gradually lower the saw until its shoe rests flat on the material to be cut. Advance saw along the cutting line until cut is completed. Release trigger and allow blade to stop completely before withdrawing the blade from the

material. When starting each new cut, repeat as above. Never tie the blade guard in a raised position.

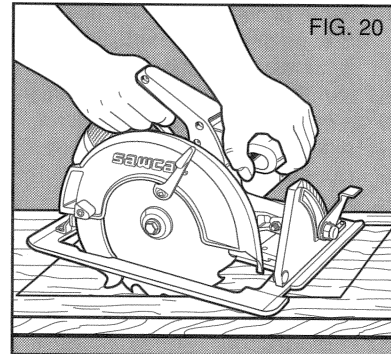

FIG. 20

Kickback

When the saw blade becomes pinched or twisted in the cut kickback can occur. The saw is thrust rapidly back toward the operator. When the blade is pinched or bound tightly by the kerf closing down, the blade stalls and the motor reaction drives the unit backward. When the blade becomes twisted or misaligned in the cut, the teeth at the back edge of the blade can dig into the top surface of the wood causing the blade to climb out of the kerf and jump back toward the operator.

Kickback is more likely to occur when any of the following conditions exist.

1. IMPROPER WORKPIECE SUPPORT
 - A. Sagging or improper lifting of the cut off piece causing pinching of the blade.
 - B. Cutting through material supported at the outer ends only (see Figure 17). As the material weakens it sags, closing down the kerf and pinching the blade.
 - C. Cutting of a cantilevered or overhanging piece of material from the bottom up in a vertical direction. The falling cut off piece can pinch the blade.
 - D. Cutting off long narrow strips (as in ripping). The cut off strip can sag or twist closing the kerf and pinching the blade.
 - E. Snagging the lower guard on a surface below the material being cut momentarily reducing operator control. The saw can lift partially out of the cut increasing the chance of blade twist.

2. IMPROPER DEPTH OF CUT SETTING ON SAW

Using the saw with an excessive depth of cut setting increases loading on the unit and susceptibility to twisting of the blade in the kerf. It also increases the surface area of the blade available for pinching under conditions of kerf close down.

3. BLADE TWISTING (MISALIGNMENT IN CUT)

- A. Pushing harder to cut through a knot, a nail, or a hard grain area can cause the blade to twist.
- B. Trying to turn the saw in the cut (trying to get back on the marked line) can cause blade twist.
- C. Extended reach or operating saw with poor body control (out of balance), can result in twisting the blade.
- D. Changing hand grip or body position while cutting can result in blade twist.
- E. Backing unit up to clear blade can lead to twist if not done carefully.

4. MATERIALS THAT REQUIRE EXTRA ATTENTION

- A. Wet lumber
- B. Green lumber (material freshly cut or not kiln dried)
- C. Pressure treated lumber (material treated with preservatives or anti-rot chemicals)

5. USE OF DULL OR DIRTY BLADES

Dull blades cause increased loading of the saw. To compensate, an operator will usually push harder which further loads the unit and promotes twisting of the blade in the kerf. Worn blades may also have insufficient body clearance which increases the chance of binding and increased loading.

6. LIFTING THE SAW WHEN MAKING BEVEL CUTS

Bevel cuts require special operator attention to proper cutting techniques - especially guidance of the saw. Both blade angle to the shoe and greater blade surface in the material increase the chance for binding and misalignment (twist) to occur.

7. RESTARTING A CUT WITH THE BLADE TEETH JAMMED AGAINST THE MATERIAL

The saw should be brought up to full operating speed before starting a cut or restarting a cut after the unit has been stopped with the blade in the kerf. Failure to do so can cause stalling and kickback.

Any other conditions which could result in pinching, binding, twisting, or misalignment of the blade could cause kickback. Refer to the sections on "Adjustments And Set-Up" and "Operation" for procedures and techniques that will minimize the occurrence of kickback.

Blades

A dull blade will cause slow, inefficient cutting overload on the saw motor, excessive splintering and could increase the possibility of kickback. It is a good practice to keep extra blades on hand so that sharp blades are available while the dull ones are being sharpened (See "SAWS-SHARPENING" in the Yellow Pages). In fact, many lower priced blades can be replaced with new ones at very little cost over the sharpening price.

Hardened gum on the blade will slow down the cutting. This gum can best be removed with trichlorethylene, kerosene, turpentine or oven cleaner.

Black & Decker manufactures a complete line of saw blades and the following types of blades are available from your dealer.

Accessories

The accessories listed in this manual are available at extra cost from your local dealer or Black & Decker Service Center. A complete listing of service centers is included on the owner's registration card packed with your tool.

If you need assistance in locating any accessory, please contact:
 Black & Decker (U.S.) Inc.
 Consumer Service Department
 626 Hanover Pike
 P.O. Box 618
 Hampstead, MD 21074-0618

- A. RIP FENCE . . . Attaches to top of Saw shoe. Permits rip cuts without penciled guide line.
- B. SAW PROTRACTOR . . . Guides Saw for accurate cut-off work. Adjusts from 0 to 70 degrees.
- C. CUT-OFF GUIDE . . . For 90 degree or 45 degree cuts.
- D. CARRYING CASE . . . Protects your Saw. Keeps blades, extension cords, etc. handy on the job.
- E. SAFETY SPECTACLES... Designed to fit over standard glasses.
- F. FILTER MASK

CAUTION: Recommended accessories and saw blades for your Saw are listed in this manual. The use of any other accessory or attachment may be hazardous.

VISUALLY EXAMINE CARBIDE BLADES BEFORE USE. REPLACE IF DAMAGED.

BLADE TYPE
COMBINATION - For general- purpose ripping and cutting
CROSS-CUT - For smoother, faster cross-cutting
RIPPING - For fast rip cuts
PLYWOOD - For smooth cuts in plywood. Reduce splintering.
FRAMING / RIP - For facing, roofing, siding, sub-flooring, framing, form cutting.
PLANER - For very smooth ripping and cross-cutting.
FRICTION - For cutting corrugated, galvanized sheets.
METAL-CUTTING - For cutting aluminum, copper, lead and other soft metals.
FLOORING - For sawing where nails may be occasionally encountered.
CARBIDE-TIPPED - For longest sawing without blade sharpening. Cuts wood, Transite, Cemesto board, Asbestos, Formica, Masonite, and similar materials

The above blades are available in 7 1/4" & 8 1/4" diameters. Use only the sizes identified on the nameplate of your saw.

Cleaning & Lubrication

Use only mild soap and a damp cloth to clean the tool. Many household cleaners contain chemicals which could seriously damage plastic. Also, do not use gasoline, turpentine, lacquer or paint thinner, dry cleaning fluids or similar products. Never let any liquid get inside the tool; never immerse any part of the tool into a liquid.

Self lubricating bearings are used in the tool and relubrication is not required. However, it is recommended that, once a year, you take or send the tool to a B & D Service Center for a thorough cleaning, inspection and lubrication of the gear case.

Extension Cords

Tools that have 3 wire cords requiring grounding must only be used with extension cords that have 3-prong grounding type plugs and 3-pole receptacles. Double insulated tools have two wire cords and can be used with two wire or three wire extension cords. Only round jacketed extension cords should be used, and we recommend that they be listed by Underwriters Laboratories (U.L.) (C.S.A. in Canada). If the extension will be used outside, the cord must be suitable for outdoor use. Any cord marked as outdoor can also be used for indoor work. The letters "WA" on the cord jacket indicate that the cord is suitable for outdoor use. Example: SJTWA which means Thermo plastic, thin jacketed, outdoor electrical cable.

An extension cord must have adequate wire size (AWG or American wire Gauge) for safety, and to prevent loss of power and overheating. The smaller the gauge number of the wire, the greater the current carrying capacity of the cable, that is 16 gauge has more current carrying capacity than 18 gauge. When using more than one extension to make up the total length, be sure each individual extension contains at least the minimum wire size.

To determine the minimum wire size required, refer to the chart below:

CHART FOR MINIMUM WIRE SIZE (AWG) OF EXTENSION CORDS

NAMEPLATE RATING-AMPS	TOTAL EXTENSION CORD LENGTH-FEET							
	25	50	75	100	125	150	175	200
0 - 10.0	18	18	16	16	14	14	12	12
10.1 - 13.0	16	16	14	14	14	12	12	12
13.1 - 15.0	14	14	12	12	12	12	12	----

Before using an extension cord, inspect it for loose or exposed wires, damaged insulation, and defective fittings. Make any needed repairs or replace the cord if necessary. Black & Decker has extension cords available that are U.L. (C.S.A. in Canada) listed for outdoor use.

Important!

To assure product SAFETY and RELIABILITY, particularly for Double Insulated tools, repairs, maintenance and adjustment (excluding maintenance described in this manual) should be performed by BLACK & DECKER Service Centers or other qualified service organizations, always using identical BLACK & DECKER replacement parts.

Commercial/Industrial Use Warranty

Black & Decker (U.S.) Inc. warrants this product for one year from date of purchase. We will repair without charge, any defects due to faulty material or workmanship. Please return the complete unit, transportation prepaid, to any Black & Decker Service Center or Authorized Service Station listed under "Tools Electric" in the yellow pages. This warranty does not apply to accessories or damage caused where repairs have been made or attempted by others.

Every Black & Decker tool is of the highest quality. If you wish to contact us regarding this product, please call toll free between 8:00 a.m. and 5:00 p.m. EST, Monday through Friday. 1-800-762-6672

Like most Black & Decker products your tool is listed by Underwriters Laboratories to ensure that it meets stringent safety requirements.

This symbol on the nameplate means the product is listed by Underwriters Laboratories, Inc.



See 'Tools-Electric'
—Yellow Pages—
for Service & Sales



BLACK & DECKER®

BLACK & DECKER (U.S.) INC., U.S. Power Tools Group, 10 North Park Drive, P.O. Box 798, Hunt Valley, MD 21030-0798 U.S.A.

Form No. 158573

(NOV90-CD-1) Copyright ©1990 Black & Decker Printed in U.S.A.