

*If you have questions or comments, contact us.
Pour toute question ou tout commentaire, nous contacter.
Si tiene dudas o comentarios, contáctenos.*

1-888-895-4549 • www.DEWALT.com

INSTRUCTION MANUAL
GUIDE D'UTILISATION
MANUAL DE INSTRUCCIONES

INSTRUCTIVO DE OPERACIÓN, CENTROS DE SERVICIO Y
PÓLIZA DE GARANTÍA. **ADVERTENCIA:** LÉASE ESTE
INSTRUCTIVO ANTES DE USAR EL PRODUCTO.

DEWALT®

DXCM601

Single Stage, Belt Drive, Electric Air Compressor

Compresseur d'air électrique à un étage à entraînement par courroie

Compresor eléctrico de aire, de una sola etapa y accionamiento por correa

(JUNE 18)

MAT Industries, LLC, Long Grove, IL 60047
Part No. E111389 DXCM601 Copyright © 2018 DEWALT

Air Compressor

- A. Pump Air Intake Filter
- B. Auto(-)/Off(O) Switch
- C. Air Tank Pressure Gauge
- D. Air Outlet
- E. Safety Valve
- F. Air Tank Drain Valve
- G. Pump Oil Fill Plug
- H. Pump Oil Drain Plug
- I. Check Valve

Pump Specifications

- 2 Cylinder
- Single Stage
- Oil Lubricated
- Cast iron crankcase, cylinder, and aluminum head

Weight: 27.0 lbs (12.2 kg.)

Oil Capacity: 16 fl. oz. (473 mL)

Specifications

MODEL	DXCM601
WEIGHT	200 lbs. (90.7 kg)
HEIGHT	65"
WIDTH	22.5"
AIR TANK CAPACITY	60 gallons (227.1 liters)
APPROX. CUT OUT PRESSURE	155 PSI
AIR DELIVERY	13.4 SCFM at 40 PSI 11.5 SCFM at 90 PSI
TANK FILL TIME	7 MINUTES
INPUT	240V, 60Hz, Single Phase AC only, 15 Amps
MINIMUM BRANCH CIRCUIT REQUIREMENT	20 AMPS
FUSE TYPE	Time Delay

Fig. 0

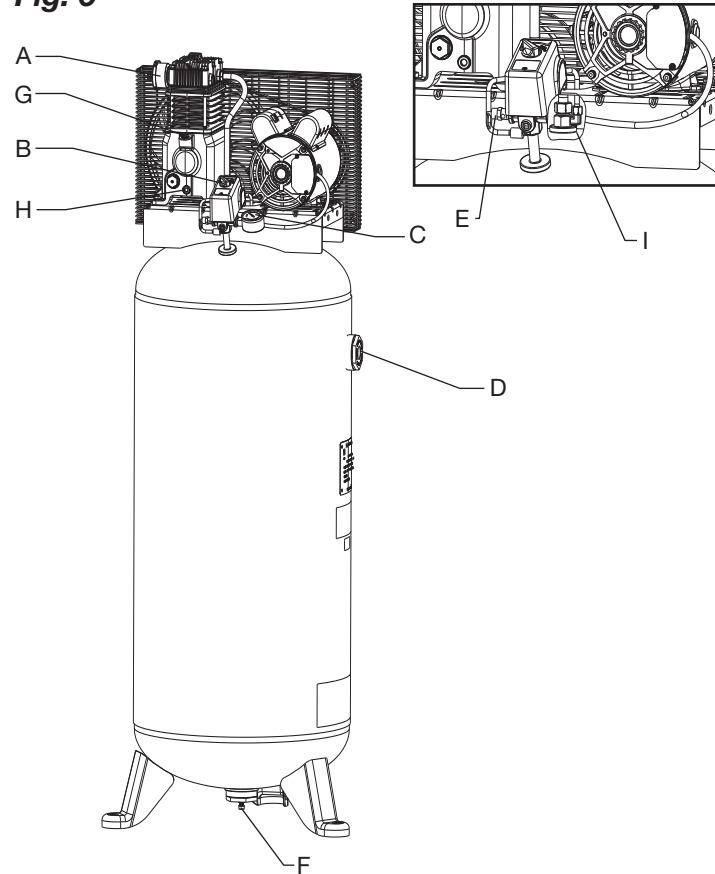



Fig. 1 Hot Surfaces

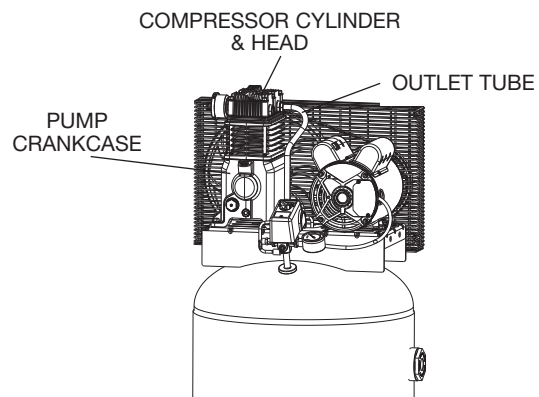

Fig. 3

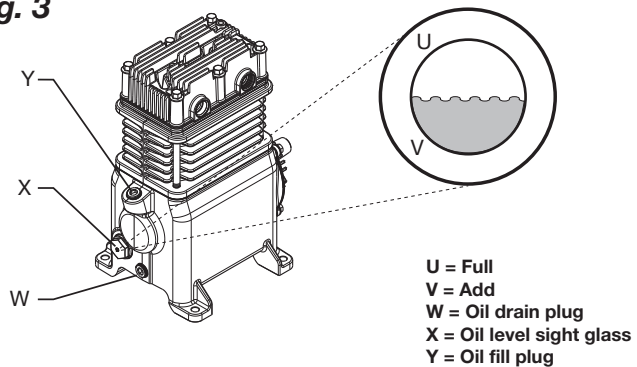
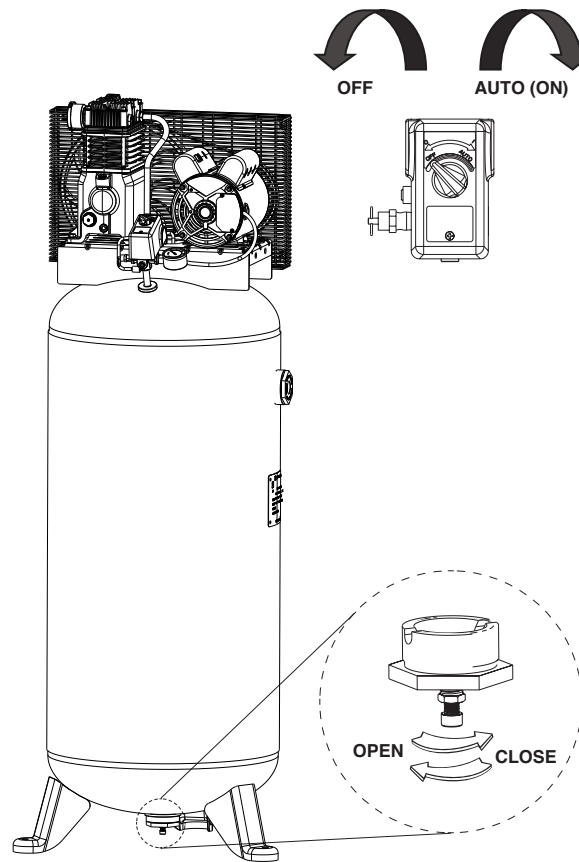

Fig. 2



English

Definitions: Safety Guidelines

The definitions below describe the level of severity for each signal word. Please read the manual and pay attention to these symbols.

⚠ DANGER: Indicates an imminently hazardous situation which, if not avoided, **will** result in **death or serious injury**.

⚠ WARNING: Indicates a potentially hazardous situation which, if not avoided, **could** result in **death or serious injury**.

⚠ CAUTION: Indicates a potentially hazardous situation which, if not avoided, **may** result in **minor or moderate injury**.

NOTICE: Indicates a practice **not related to personal injury** which, if not avoided, **may** result in **property damage**.

IF YOU HAVE ANY QUESTIONS OR COMMENTS ABOUT THIS OR ANY DEWALT TOOL, CALL US TOLL FREE AT: **1-888-895-4549**

Important Safety Instructions

⚠ WARNING: Do not operate this unit until you read this instruction manual for safety, operation and maintenance instructions.

WARNING: CONTAINS LEAD. May be harmful if eaten or chewed. May generate dust containing lead. Wash hands after use. Keep out of reach of children.

⚠ WARNING: This product can expose you to chemicals including lead, which is known to the State of California to cause cancer and birth defects or other reproductive harm. For more information go to www.P65Warnings.ca.gov.

SAVE THESE INSTRUCTIONS



⚠ DANGER: RISK OF EXPLOSION OR FIRE

WHAT CAN HAPPEN

- It is normal for electrical contacts within the motor and pressure switch to spark.
- If electrical sparks from compressor come into contact with flammable vapors, they may ignite, causing fire or explosion.
- Restricting any of the compressor ventilation openings will cause serious overheating and could cause fire.

HOW TO PREVENT IT

- Always operate the compressor in a well ventilated area free of combustible materials, gasoline, or solvent vapors.
- If spraying flammable materials, locate compressor at least 20' (6.1 m) away from spray area. An additional length of air hose may be required.
- Store flammable materials in a secure location away from compressor.
- Never place objects against or on top of compressor.
- Operate compressor in an open area at least 12" (30.5 cm) away from any wall or obstruction that would restrict the flow of fresh air to the ventilation openings.
- Operate compressor in a clean, dry, well ventilated area. Do not operate unit in any confined area. Store indoors.

- Unattended operation of this product could result in personal injury or property damage. To reduce the risk of fire, do not allow the compressor to operator unattended
- Always remain in attendance with the product when it is operating.
- Always turn off and unplug unit when not in use.



⚠ DANGER: RISK TO BREATHING (ASPHYXIATION)

WHAT CAN HAPPEN

- The compressed air directly from your compressor is not safe for breathing. The air stream may contain carbon monoxide, toxic vapors, or solid particles from the air tank. Breathing these contaminants can cause serious injury or death.
- Exposure to chemicals in dust created by power sanding, sawing, grinding, drilling and other construction activities may be harmful.
- Sprayed materials such as paint, paint solvents, paint remover, insecticides, weed killers, may contain harmful vapors and poisons.

HOW TO PREVENT IT

- Never use air obtained directly from the compressor to supply air for human consumption. The compressor is not equipped with suitable filters and in-line safety equipment for human consumption.
- Work in an area with good cross ventilation. Read and follow the safety instructions provided on the label or safety data sheets for the materials you are spraying. Always use certified safety equipment: NIOSH/OSHA respiratory protection or properly fitting face mask designed for use with your specific application.



▲ DANGER: RISK OF BURSTING

Air Tank: On February 26, 2002, the U.S. Consumer Product Safety Commission published Release # 02-108 concerning air compressor tank safety:

Air compressor receiver tanks do not have an infinite life. Tank life is dependent upon several factors, some of which include operating conditions, ambient conditions, proper installations, field modifications, and the level of maintenance. The exact effect of these factors on air receiver life is difficult to predict.

If proper maintenance procedures are not followed, internal corrosion to the inner wall of the air receiver tank can cause the air tank to unexpectedly rupture allowing pressurized air to suddenly and forcefully escape, posing risk of injury to consumers.

Your compressor air tank must be removed from service by the end of the year shown on your tank warning label.

The following conditions could lead to a weakening of the air tank, and result in a violent air tank explosion:

WHAT CAN HAPPEN

- Failure to properly drain condensed water from air tank causes rust and thinning of the steel air tank.
- Modifications or attempted repairs to the air tank.

HOW TO PREVENT IT

- Drain air tank daily or after each use. If air tank develops a leak, replace it immediately with a new air tank or replace the entire compressor.
- Never drill into, weld or make any modifications to the air tank or its attachments. Never attempt to repair a damaged or leaking air tank. Replace with a new air tank.

- Unauthorized modifications to the safety valve, or any other components which control air tank pressure.
- The air tank is designed to withstand specific operating pressures. Never make adjustments or part substitutions to alter the factory set operating pressures.

Attachments & Accessories:

- Exceeding the pressure rating of air tools, spray guns, air operated accessories, tires and other inflatables can cause them to explode or fly apart, and could result in serious injury.
- Follow the equipment manufacturers recommendation and never exceed the maximum allowable pressure rating of attachments. Never use compressor to inflate small low pressure objects such as children's toys, footballs, basketballs, etc.

Tires:

- Over inflation of tires could result in serious injury and property damage.
- Use a tire pressure gauge to check the tires pressure before each use and while inflating tires; see the tire sidewall for the correct tire pressure.

NOTE: Air tanks, compressors and similar equipment used to inflate tires can fill small tires very rapidly. Adjust pressure regulator on air supply to no more than the rating of the tire pressure. Add air in small increments and frequently use the tire gauge to prevent over inflation.



⚠ DANGER: RISK OF INJURY OR PROPERTY DAMAGE WHEN TRANSPORTING OR STORING

WHAT CAN HAPPEN

- Oil can leak or spill and could result in fire or breathing hazard; serious injury or death can result. Oil leaks will damage carpet, paint or other surfaces in vehicles or trailers.

HOW TO PREVENT IT

- Always place compressor on a protective mat when transporting to protect against damage to vehicle from leaks. Remove compressor from vehicle immediately upon arrival at your destination. Always keep compressor level and never lie on its side.



⚠ WARNING: RISK FROM FLYING OBJECTS

WHAT CAN HAPPEN

- The compressed air stream can cause soft tissue damage to exposed skin and can propel dirt, chips, loose particles and small objects at high speed, resulting in property damage or personal injury.

HOW TO PREVENT IT

- Always wear certified safety equipment: ANSI Z87.1 eye protection (CAN/CSA Z94.3) with side shields when using the compressor.
- Never point any nozzle or sprayer toward any part of the body or at other people or animals.
- Always turn the compressor off and bleed pressure from the air hose and air tank before attempting maintenance, attaching tools or accessories.



⚠ WARNING: RISK OF HOT SURFACES

WHAT CAN HAPPEN

- Touching exposed metal such as the compressor head or outlet tubes, can result in serious burns.

HOW TO PREVENT IT

- Never touch any exposed metal parts on compressor during or immediately after operation. Compressor will remain hot for several minutes after operation
- Do not reach around protective shrouds or attempt maintenance until unit has been allowed to cool.



⚠ WARNING: RISK OF ELECTRICAL SHOCK

WHAT CAN HAPPEN

- Your compressor is powered by electricity. Like any other electrically powered device, if it is not used properly it may cause electric shock.

HOW TO PREVENT IT

- Never operate the compressor outdoors when it is raining or in wet conditions.
- Never operate compressor with protective covers removed or damaged.

- Repairs attempted by unqualified personnel can result in serious injury or death by electrocution.
- Any electrical wiring or repairs required on this product should be performed by authorized service center personnel in accordance with national and local electrical codes.
- **Electrical Grounding:** Failure to provide adequate grounding to this product could result in serious injury or death from electrocution. Refer to **Grounding Instructions** paragraph in the *Installation* section.
- Make certain that the electrical circuit to which the compressor is connected provides proper electrical grounding, correct voltage and adequate protection.



⚠ WARNING: RISK OF UNSAFE OPERATION

WHAT CAN HAPPEN

- Unsafe operation of your air compressor could lead to serious injury or death to you or others.

HOW TO PREVENT IT

- Review and understand all instructions and warnings in this manual.
- Become familiar with the operation and controls of the air compressor.
- Keep operating area clear of all persons, pets, and obstacles.
- Keep children away from the air compressor at all times.
- Do not operate the product when fatigued or under the influence of alcohol or drugs. Stay alert at all times.
- Never defeat the safety features of this product.
- Equip area of operation with a fire extinguisher.
- Do not operate machine with missing, broken, or unauthorized parts.
- Never stand on the compressor.



⚠ WARNING: RISK FROM MOVING PARTS

WHAT CAN HAPPEN

- Moving parts such as the pulley, flywheel, and belt can cause serious injury if they come into contact with you or your clothing.
- Attempting to operate compressor with damaged or missing parts or attempting to repair compressor with protective shrouds removed can expose you to moving parts and can result in serious injury.

HOW TO PREVENT IT

- Never operate the compressor with guards or covers which are damaged or removed.
- Keep your hair, clothing and gloves away from moving parts. Loose clothes, jewelry or long hair can be caught in moving parts.
- Air vents may cover moving parts and should be avoided as well.
- Any repairs required on this product should be performed by a DEWALT factory service center or a DEWALT authorized service center.



▲ **WARNING: RISK OF INJURY FROM LIFTING**

WHAT CAN HAPPEN

- Serious injury can result from attempting to lift too heavy an object.

HOW TO PREVENT IT

- The compressor is too heavy to be lifted by one person. Obtain assistance from others before lifting.



▲ **CAUTION: RISK FROM NOISE**

WHAT CAN HAPPEN

- Under some conditions and duration of use, noise from this product may contribute to hearing loss.

HOW TO PREVENT IT

- Always wear certified safety equipment: ANSI S12.6 (S3.19) hearing protection.

SAVE THESE INSTRUCTIONS FOR FUTURE USE

Know Your Air Compressor

READ THIS OWNER'S MANUAL AND SAFETY RULES BEFORE OPERATING YOUR UNIT. Compare the illustrations with your unit to familiarize yourself with the location of various controls and adjustments. Save this manual for future reference.

FEATURES

AUTO (-) / OFF (O) SWITCH

Place this switch (B) in the AUTO (-) position to provide automatic power to the pressure switch and OFF (O) to remove power at the end of each use. **NOTE:** ALWAYS ensure the switch (B) is in the OFF (O) position and unit is unplugged before removing or replacing pressure switch cover.

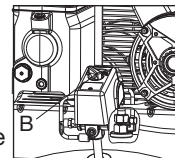

PRESSURE SWITCH

The pressure switch (not shown) automatically starts the motor when the air tank pressure drops below the factory set cut-in pressure. It stops the motor when the air tank pressure reaches the factory set cut-out pressure.

SAFETY VALVE

This valve (E) is designed to prevent system failures by relieving pressure from the system when the compressed air reaches a predetermined level. The valve is preset by the manufacturer and must not be removed or modified in any way.

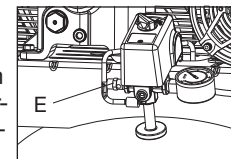

CHECK VALVE

When the air compressor is operating, the check valve (I) is open, allowing compressed air to enter the air tank. When the air compressor reaches cut-out pressure, the check valve closes, allowing air pressure to remain inside the air tank.

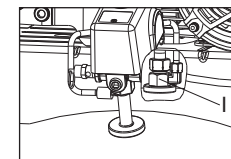

AIR INTAKE FILTER

The filter (A) is designed to clean air entering the pump. To ensure the pump continually receives a clean, cool, and dry air supply, the filter must always be clean and the filter intake must be free from obstructions.

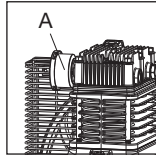

AIR TANK DRAIN VALVE

The drain valve (F) is located at the base of the air tank and is used to drain condensation at the end of each use. See Draining Air Tank under *Maintenance*.

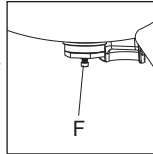

TANK PRESSURE GAUGE

The tank pressure gauge (C) indicates the reserve air pressure in the tank.

REGULATOR

(sold separately, not shown)

An air pressure regulator or a separate air transformer which combines the functions of air regulation and/or moisture and dirt removal is recommended for most applications. See Air Distribution System paragraph under *Installation*.

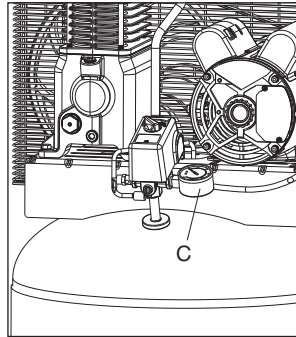

⚠ WARNING: Risk of Bursting. Too much air pressure causes a hazardous risk of bursting. Check the manufacturer's maximum pressure rating for air tools and accessories. The outlet pressure must never exceed the maximum pressure rating of the tools or accessories.

AIR COMPRESSOR PUMP

The pump compresses air into the air tank. Working air is not available until the compressor has raised the air tank pressure above that required at the air outlet.

MOTOR OVERLOAD PROTECTOR

The motor has a thermal overload protector. If the motor overheats for any reason, the overload protector will shut off the motor. The motor must be allowed to cool down before restarting. To restart:

1. Set the Auto/Off switch to OFF (O) and unplug unit.
2. Allow the motor to cool.
3. Depress the red reset button (N) on the motor.
4. Plug the power cord into the correct branch circuit receptacle.
5. Set the Auto/Off switch to AUTO (-).

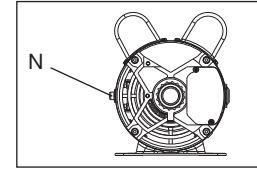

INSTALLATION

Assembly

Unpack the air compressor. Inspect the unit for damage. If the unit has been damaged in transit, contact the carrier and complete a damage claim. Do this immediately because there are time limitations to damage claims.

The carton should contain:

- air compressor
- operator's manual

Check the compressor's serial label to ensure that you have received the model ordered, and that it has the required pressure rating for its intended use.

INSTALLING HOSES

▲ WARNING: Risk of unsafe operation. Firmly grasp hose in hand when installing or disconnecting to prevent hose whip.

1. Ensure regulated pressure gauge reads 0 PSI (0 kPa).
2. Apply sealant tape to hose threads.
3. Assemble hose to air outlet (D). **IMPORTANT:** Do not assemble splitters directly to the air outlet (D) (Fig 0).

NOTE: Assembling quick connect bodies to air outlet and quick connect plugs to hose ends make connecting and disconnecting hoses simple and easy. Quick connect bodies and plugs are available for purchase from your local dealer or authorized service center.

DISCONNECTING HOSES

▲ WARNING: Risk of unsafe operation. Firmly grasp hose in hand when installing or disconnecting to prevent hose whip.

1. Ensure regulated pressure gauge reads 0 PSI (0kPa).
2. Remove hose from air outlet (D) (Fig 0).

Lubrication and Oil

AIR COMPRESSOR

The air compressor pump was filled **WITH** oil at the manufacturer. Check air compressor pump oil level before operating unit. See **Compressor Pump Oil** under *Maintenance*.

Compatibility

Air tools and accessories that are run off the compressor must be compatible with petroleum based products. If you suspect that a material is not compatible with petroleum products, an air line filter for removal of moisture and oil vapor in compressed air is required.

NOTE: Always use an air line filter to remove moisture and oil vapor when spraying paint.

Location

- Locate the air compressor in a clean, dry, and well ventilated area.
- Locate the air compressor at least 12" (30.5 cm) away from the wall or other obstructions that will interfere with the flow of air.
- Locate the air compressor as close to the main power supply as possible to avoid using long lengths of electrical wiring. **NOTE:** Long lengths of electrical wiring could cause power loss to the motor.
- The air filter must be kept clear of obstructions which could reduce air flow to the air compressor.

HUMID AREAS

In frequently humid areas, moisture may form in the pump and produce sludge in the oil, causing running parts to wear out prematurely. Excessive moisture is especially likely to occur if the unit is located in an unheated area that is subject to large temperature changes. Two signs of excessive humidity are external condensation on the pump when it cools down and a "milky" appearance in compressor oil. You may be able to prevent moisture from forming in the pump by increasing ventilation or operating for longer intervals.

NOISE CONSIDERATIONS

Consult local officials for information regarding acceptable noise levels in your area. To reduce excessive noise, use vibration mounts or silencers, relocate the unit or construct total enclosures or baffle walls. Contact a DEWALT service center or call 1-888-895-4549 for assistance.

ANCHORING OF THE AIR COMPRESSOR

⚠ WARNING: Risk of bursting. Excessive vibration can weaken the air tank and cause an explosion. The compressor must be properly mounted.

The air compressor MUST be bolted to a level, solid concrete surface. Use 3/8" lag screws, vibration pads and concrete anchors. If help is needed anchoring the air compressor consult a licensed contractor.

1. Place the air compressor on a level, solid concrete surface. Make sure the concrete is in good condition with no cracks or damage.
2. Mark the surface using the holes in the air compressor feet as a template.
3. Drill holes in the surface for the concrete anchors. Install concrete anchors.
4. Line-up holes in surface with holes in air compressor feet.
5. Place the vibration pads (not supplied) between the floor and air compressor feet, see figure. If needed use shims to level the unit.
6. Place the 3/8" lag screws through the air compressor feet, vibration pads and into the anchors.
7. Torque 3/8" lag screws to 7-10 ft.-lbs (9.5-13.5 Nm).

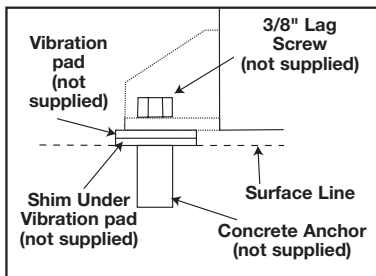

Electrical Wiring

⚠ WARNING: Improper electrical installation of this product may void its warranty and your fire insurance. Have circuit wiring performed by qualified personnel such as a licensed electrician who is familiar with the current national electrical code and any prevailing local electrical codes.

⚠ WARNING: Risk of electrical shock. Improper electrical grounding can result in electrical shock. The wiring should be done by a qualified electrician.

A qualified electrician needs to know the following before wiring:

1. The amperage rating of the electrical box is adequate. Refer to the *Specifications*, in the parts manual, for this information.
2. If the supply line has the same electrical characteristics (voltage, cycle, phase) as the motor. Refer to the motor nameplate, on side of motor, for this information.

NOTE: The wiring used must be rated for the motor nameplate voltage, plus or minus 10%. Refer to local codes for recommended wire sizes, correct wire size, and maximum wire run. Undersized wire causes high amp draw and overheating to the motor.

NOTE: A circuit breaker is recommended. If the air compressor is connected to a circuit protected by a fuse, use only time delay fuses.

⚠ WARNING: Risk of electrical shock. Electrical wiring must be located away from hot surfaces such as manifold assembly, compressor outlet tubes, heads, or cylinders.

Grounding Instructions

▲WARNING: Risk of electrical shock. In the event of a short circuit, grounding reduces the risk of shock by providing an escape wire for the electric current. This air compressor must be properly grounded.

This product should be connected to a grounded, metallic, permanent wiring system, or an equipment-grounding terminal or lead on the product.

▲DANGER: Risk of electrical shock. **IMPROPER GROUNDING CAN RESULT IN ELECTRICAL SHOCK.**

Voltage and Circuit Protection

Refer to the Voltage and Minimum Branch Circuit Requirements under *Specifications*.

- Voltage supply to circuit must comply with the National Electrical Code.
- Circuit is not used to supply any other electrical needs.

Main Power Disconnect Switch

Install a main power disconnect switch in the line from the panel to the compressor. The main power disconnect switch must be located near the compressor, for ease of use and safety. When turned OFF, the main power disconnect switch shuts off all power to the compressor. When it is turned ON, the compressor will start and stop automatically, controlled by the pressure switch.

Air Distribution System

▲WARNING: Risk of bursting. Plastic or PVC pipe is not designed for use with compressed air. Regardless of its indicated pressure rating, plastic pipe can burst from air pressure. Use only metal pipe for air distribution lines.

INSTALLING AND DISCONNECTING HOSES

▲WARNING: Risk of unsafe operation. Firmly grasp hose in hand when installing or disconnecting to prevent hose whip. Ensure regulated pressure gauge reads 0 PSI.

The next figure represents a typical air distribution system. The following are tips to remember when setting up the air compressor's air distribution system.

NOTE: Compressed air from oil lubed air compressors will contain water condensation and oil mist. Several drains, traps and filters will be needed to supply air without water (including aerosols) or oil to spray equipment, air tools and accessories requiring filtered air. Always read the instructions for the air tools and accessories being used.

- Use pipe that is the same size as the air tank outlet. Piping that is too small will restrict the flow of air.
- If piping is over 100' (30.5 m) long, use the next larger size.
- Bury underground lines below the frost line and avoid pockets where condensation can gather and freeze. Apply pressure before underground lines are covered to make sure all pipe joints are free of leaks.
- A flexible coupling is recommended to be installed between the globe valve/air discharge outlet and main air distribution line to allow for vibration.
- A separate regulator is recommended to control the air pressure. Air pressure from the tank is usually too high for individual air driven tools.
- DO NOT install lubricators between the tank and any spray equipment, air tool or accessory requiring oil-free filtered air.
- Drain all traps, filters and dirt legs daily.

TYPICAL COMPRESSED AIR DISTRIBUTION SYSTEM

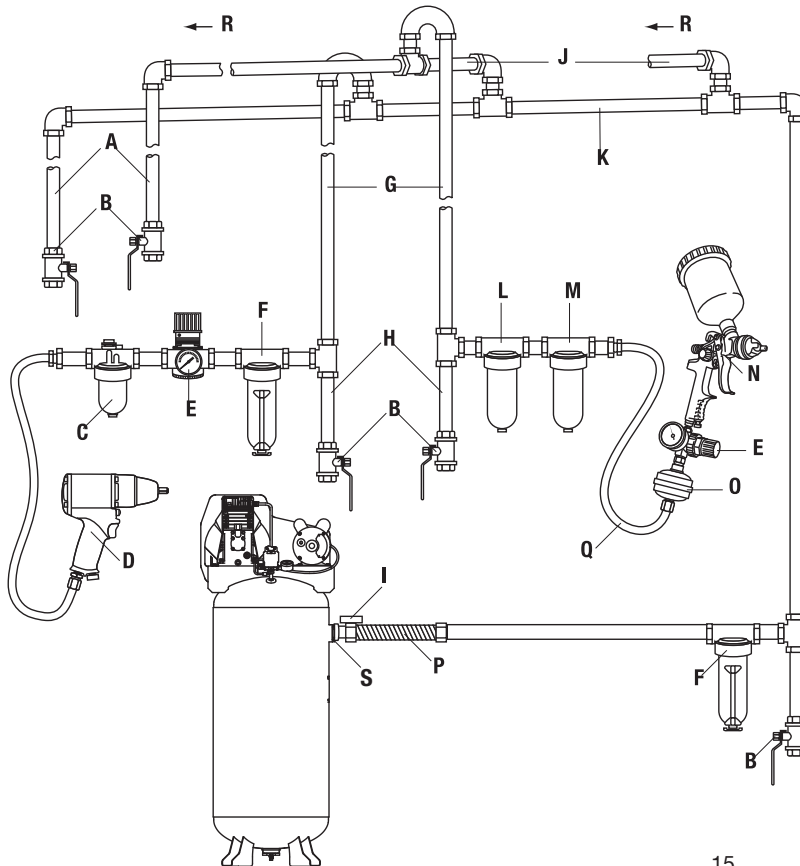

15

Part	Description
A	Drain Legs
B	Drain Valves
C	Lubricator
D	Air Tool
E	Regulator
F	Filter / Moisture Trap
G	Air Usage Lines
H	Dirt Legs
I	Air Discharge Valve
J	Feeder Lines Slope with Air Flow
K	Main Distribution Air Lines - Slope pipe in direction of air flow. Water condensate flows along bottom of pipe to drain legs, preventing it from entering feeder lines.
L	5 Micron Filter
M	.01 Micron Filter
N	Spray Gun
O	Ball Fitter
P	Flexible Coupling
Q	For Best Performance - The distance between the compressor and the moisture trap should be as long as possible.
R	Air Flow
S	Air Outlet

How to Use Your Unit (Fig 2)

How to Stop:

Set the Auto/Off switch to “OFF (O)”.

Before Starting

▲WARNING: Do not operate this unit until you read this instruction manual for safety, operation and maintenance instructions.

Break-in Procedure

NOTICE: Risk of property damage. Serious damage may result if the following break-in instructions are not closely followed.

This procedure is required **before** the air compressor is put into service and when the check valve or a complete compressor pump has been replaced.

1. Make sure the Auto/Off switch is in the “OFF (O)” position.
2. Check oil level in pump. See **Oil** paragraph in the *Maintenance* section for instructions.
3. Recheck all wiring. Make sure wires are secure at all terminals connections. Make sure all contacts move freely and are not obstructed.
4. Open the drain valve (clockwise) fully to permit air to escape and prevent air pressure build up in the air tank during the break-in period.
5. Move the Auto/Off switch to “AUTO (-)” position. The compressor will start.
6. Run the compressor for 30 minutes. Make sure the drain valve and all air lines are open so there is only a minimal air pressure build-up in tank. **NOTE:** After about 30 minutes, If the unit does not operate properly, SHUT DOWN IMMEDIATELY, and contact Product Service.

7. Check all air line fittings and connections/piping for air leaks by applying a soap solution. Correct if necessary. **NOTE:** Minor leaks can cause the air compressor to overwork, resulting in premature breakdown or inadequate performance.
8. Check for excessive vibration. Re-adjust or shim air compressor feet, if necessary.
9. After 30 minutes, turn the Auto/Off switch to the “OFF (O)” position.
10. Close the drain valve.
11. Turn the Auto/Off switch to the “AUTO (-)” position. The air receiver will fill to “cut-out” pressure and the motor will stop.

The compressor is now ready for use.

Before Each Start-Up (Fig. 2)

1. Every day check the sight glass to ensure that the level of oil in the pump is at the required level.
2. Place Auto/Off switch to “OFF (O)”.
3. Close the drain valve.
4. Visually inspect air lines and fittings for leaks.
5. Check safety valve. See **To Check Safety Valve** under *Maintenance*.
6. Attach hose and accessories.

▲WARNING: Risk of unsafe operation. Firmly grasp air hose in hand when installing or disconnecting to prevent hose whip.

▲WARNING: Risk of unsafe operation. Do not use damaged or worn accessories.



NOTE: The hose or accessory will require a quick connect plug if the air outlet is equipped with a quick connect socket.

NOTE: A regulator **MUST** be used if the air pressure required for the accessory is less than the maximum air pressure supplied from the air compressor.

⚠WARNING: Risk of bursting. Too much air pressure causes a hazardous risk of bursting. Check the manufacturer's maximum pressure rating for air tools and accessories. The regulator outlet pressure must never exceed the maximum pressure rating.

⚠CAUTION: Risk of unsafe operation. Compressed air from the unit may contain water condensation and oil mist. Do not spray unfiltered air at an item that could be damaged by moisture. Some air tools and accessories may require filtered air. Read the instructions for the air tools and accessories.

How to Start

1. Turn the Auto/Off switch to "AUTO (-)" and allow tank pressure to build. Motor will stop when tank pressure reaches "cut-out" pressure.
2. When the tank pressure reaches "cut-out" pressure open the air discharge valve.

IMPORTANT: When using a regulator and other accessories refer to the manufacturer's instructions.

⚠WARNING: Risk of bursting. If any unusual noise or vibration is noticed, stop the compressor immediately and have it checked by a trained service technician.

The compressor is ready for use.

Shut-down (Fig. 2)

1. Move Auto/Off switch to the OFF (O) position.

NOTE: If finished using compressor, follow Steps 2 - 5.

2. Drain the air tank, see Draining Air Tank under *Maintenance*. Ensure air tank pressure gauge reads 0 PSI (0 kPa).

⚠WARNING: Risk of unsafe operation. Firmly grasp air hose in hand when installing or disconnecting to prevent hose whip.

3. Remove hose and accessory.

⚠WARNING: Risk of bursting. Drain air tank daily. Water will condense in air tank. If not drained, water will corrode and weaken the air tank causing a risk of air tank rupture.

4. Allow the compressor to cool down.
5. Wipe air compressor clean and store in a safe, non-freezing area.

MAINTENANCE

Maintenance Chart

Procedure	Daily	Weekly	Monthly	1 year or 100 Hours	See tank warning label
Check safety valve	X				
Inspect air filter		X ⁺			
Drain air tank	X				
Check pump oil level	X				
Change pump oil				X ^{***}	
Oil leak inspection	X				
Inspect drive belt	X				

Procedure	Daily	Weekly	Monthly	1 year or 100 Hours	See tank warning label
Check drive belt tension			X		
Check pulley/flywheel alignment				X	
Check for unusual noise/vibration	X				
Check for air leaks	X*				
Clean compressor exterior		X			
Remove tank from service					X++
* To check for air leaks apply a solution of soapy water around joints. While compressor is pumping to pressure and after pressure cuts out, look for air bubbles to form.					
** The pump oil must be changed after the first 20 hours of operation. Thereafter, when using semi-synthetic blend non-detergent air compressor oil, change oil every 100 hours of operation or once a year, whichever comes first.					
+ Perform more frequent in dusty or humid conditions.					
** For more information, call 1-888-895-4549 .					

⚠ WARNING: Risk of unsafe operation. Unit cycles automatically when power is on. When performing maintenance, you may be exposed to voltage sources, compressed air, or moving parts. Personal injuries can occur. Before performing any maintenance or repair, disconnect power source from the compressor and bleed off all air pressure.

To ensure efficient operation and longer life of the air compressor outfit, a routine maintenance schedule should be prepared and followed. The following routine maintenance schedule is geared to an outfit in a normal working environment operating on a daily basis. If necessary, the schedule should be modified to suit the conditions under which your compressor is used. The modifications will

depend upon the hours of operation and the working environment. Compressor outfits in an extremely dirty and/or hostile environment will require a greater frequency of all maintenance checks.

NOTE: See Operation section for the location of controls.

Checking Safety Valve

⚠ WARNING: Hot surfaces. Risk of burn. Tubes, pump head, and surrounding parts are very hot, do not touch (see the Hot Surfaces identified in Fig. 1). Allow compressor to cool prior to servicing.

⚠ WARNING: Risk of bursting. If the safety valve does not work properly, over-pressurization may occur, causing air tank rupture or an explosion.

⚠ WARNING: Risk from flying objects. Always wear certified safety equipment: ANSI Z87.1 eye protection (CAN/CSA Z94.3) with side shields.

⚠ WARNING: Risk from noise. Use ear protection (ANSI S12.6 (S3.19) as air flow noise is loud when draining.

Before starting compressor, pull the ring on the safety valve (E) to make sure that the safety valve operates freely. If the valve is stuck or does not operate smoothly, it must be replaced with the same type of valve.

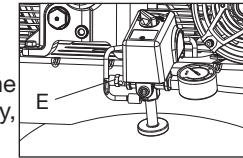

Checking Air Filter

⚠ WARNING: Hot surfaces. Risk of burn. Tubes, pump head, and surrounding parts are very hot, do not touch (see the Hot Surfaces identified in Fig. 1). Allow compressor to cool prior to servicing.

A dirty air filter will not allow the compressor to operate at full capacity. Keep the air filter clean at all times.

1. Ensure Auto/Off switch (B) is in the OFF (O) Position.
2. Allow unit to cool.

- Unsnap the air filter cover to remove (S).
- Check the filter element (T). If it is dirty, blow compressed air through the filter element for 10-15 seconds or replace if needed. If the filter is filled with paint, replace it.
- Place element into housing and reattach the air filter cover.

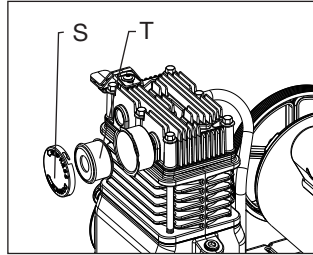

⚠ CAUTION: Risk of unsafe operation. Do not operate without air filter.

Draining Air Tank (Fig. 2)

⚠ WARNING: Risk of unsafe operation. Air tanks contain high pressure air. Keep face and other body parts away from outlet of drain. Use eye protection [ANSI Z87.1 (CAN/CSA Z94.3)] when draining as debris can be kicked up into face.

⚠ WARNING: Risk from noise. Use ear protection (ANSI S12.6 (S3.19)) as air flow noise is loud when draining.

NOTE: All compressed air systems generate condensation that accumulates in any drain point (e.g., tanks, filter, aftercoolers, dryers). This condensate contains lubricating oil and/or substances which may be regulated and must be disposed of in accordance with local, state, and federal laws and regulations.

- Set the Auto/Off switch to “OFF (O)”.
- Pull ring on safety valve allowing air to bleed from the tank until tank pressure is approximately 20 PSI. Release safety valve ring.
- Drain water from air tank by opening drain valve (clockwise) on bottom of tank.

⚠ WARNING: Risk of bursting. Water will condense in the air tank. If not drained, water will corrode and weaken the air tank causing a risk of air tank rupture.

NOTICE: Risk of property damage. Drain water from air tank may contain oil and rust which can cause stains.

- After the water has been drained, close the drain valve (counterclockwise). The air compressor can now be stored.

NOTE: If drain valve is plugged, release all air pressure. The valve can then be removed, cleaned, then reinstalled.

Compressor Pump Oil (Fig. 3)

NOTICE: Risk of property damage. Use air compressor oil only. Multi-weight automotive engine oils like 10W30 should not be used in air compressors. They leave carbon deposits on critical components, thus reducing performance and compressor life.

NOTE: Use semi-synthetic blend, non-detergent air compressor oil.

NOTE: Crankcase oil capacity is approximately 16 fluid ounces (473 ml).

Checking

- The oil level should be to the middle of the sight glass (X).
- If needed, remove oil fill plug (Y) and slowly add oil until it reaches the middle of the sight glass.

Changing

⚠ WARNING: Drain tank to release air pressure before removing the oil fill plug or oil drain plug.

- Remove the oil fill plug (Y).
- Remove the oil drain plug (W) and drain oil into a suitable container.

3. Replace the oil drain plug (W) and tighten securely
4. Slowly add compressor oil until it reaches the middle of the sight glass (X). **NOTE:** When filling the crankcase, the oil flows very slowly into the pump. If the oil is added too quickly, it will overflow and appear to be full.

▲ CAUTION: Overfilling with oil will cause premature compressor failure. Do not overfill.

5. Replace oil fill plug (Y) and tighten securely.

Belt Replacement

▲ WARNING: This unit starts automatically. ALWAYS shut off and unplug the compressor, and bleed all pressure from the system before servicing the compressor, and when the compressor is not in use. Do not use the unit with the shrouds or belt guard removed. Serious injury could occur from contact with moving parts. Hot surfaces. Risk of burn. Pump head, and surrounding parts are very hot, do not touch (see the Hot Surfaces identified in Fig. 1). Allow compressor to cool prior to servicing.

1. Set the Auto/Off lever to "OFF (O)", unplug the unit, and relieve all air pressure from the air tank.
2. Remove the outer belt guard (Z).
3. Mark motor position on saddle.
4. Loosen the motor mounting screws and slide the motor toward the air compressor pump.
5. Remove the belt and replace with a new one.
6. See the **Adjusting Belt Tension** before tightening motor mounting screws.

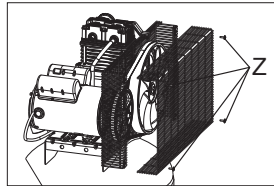

Adjusting Belt Tension

1. Slide motor into original position, line the motor up with the mark made earlier on saddle.
2. Tighten two outside motor mounting screws enough to hold the motor in place for checking pulley and flywheel alignment.
3. The belt should deflect 1/4" (6.5 mm) at midway between the pulley and the flywheel when a 10 pound (4.5 kg.) weight is applied at the midway point.
4. When proper belt tension is achieved, tighten motor mounting screws. Torque to 20-25 ft-lbs (27.1-33.9 Nm)

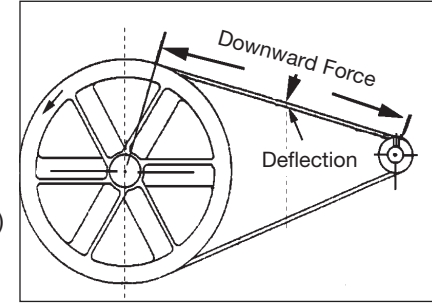

NOTE: Once the motor pulley has been moved from its factory set location, the grooves of the flywheel and pulley must be aligned to within 1/16" (1.6 mm) to prevent excessive belt wear. Verify the alignment by performing the following **Motor Pulley/Flywheel - Alignment**.

Motor Pulley/Flywheel Alignment

NOTE: Once the motor pulley has been moved from its factory set location, the grooves of the flywheel and pulley must be aligned to within 1/16" (1.6 mm) to prevent excessive belt wear.

The air compressor flywheel and motor pulley hub must be in-line (in the same plane) within 1/16" (1.6 mm) to assure belt retention

within flywheel belt grooves. To correct misalignment, perform the following steps:

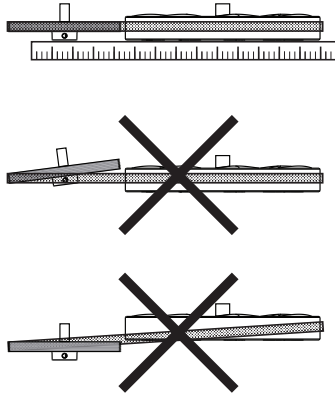

1. Set the Auto/Off lever to “OFF (O)”, unplug the unit, and relieve all air pressure from the air tank.
2. Remove the outer belt guard.
3. Loosen the motor mounting bolts.
4. Loosen the set screws on the motor pulley.
5. Align the motor pulley with the pump flywheel.
6. Retighten the motor pulley set screws. Torque 60-80 in.-lbs. (6.8 - 9.0 Nm).
7. Adjust the proper belt tension.
8. Retighten the motor mounting bolts. Torque to 20-25 ft.-lbs (27.1–33.9 Nm)
9. Reinstall the outer belt guard.
All moving parts must be guarded.

Air Compressor Pump Intake and Exhaust Valves

Once a year have a Trained Service Technician check the air compressor pump intake and exhaust valves.

Inspect Air Lines and Fittings for Leaks

1. Set the Auto/Off lever to “OFF (O)”, unplug the unit, and relieve all air pressure from the air tank.
2. Apply a soap solution to all air line fittings and connections/piping.
3. Correct any leaks found.

IMPORTANT: Even minor leaks can cause the air compressor to overwork, resulting in premature breakdown or inadequate performance.

Air compressor Head Bolts - Torquing

The air compressor pump head bolts should be kept properly torqued. Check the torques of the head bolts after the first five hours of operation. Torque to 15-20 ft.-lbs. (20.3-27.1 Nm).

Service and Adjustments

ALL MAINTENANCE AND REPAIR OPERATIONS NOT LISTED MUST BE PERFORMED BY TRAINED SERVICE TECHNICIAN.

⚠ WARNING: Risk of unsafe operation. Unit cycles automatically when power is on. When servicing, you may be exposed to voltage sources, compressed air, or moving parts. Before servicing unit unplug or disconnect electrical supply to the air compressor, bleed tank of pressure, and allow the air compressor to cool.

To Replace or Clean Check Valve

1. Release all air pressure from air tank. See **Draining Air Tank** in the *Maintenance* section.
2. Set the Auto/Off lever to “Off”, unplug the unit, and relieve all air pressure from the air tank.
3. Using an adjustable wrench loosen outlet tube nut at air tank and pump. Carefully move outlet tube away from check valve.
4. Using an adjustable wrench loosen pressure relief tube nut at air tank. Carefully move pressure relief tube away from check valve.
5. Unscrew the check valve (turn counter-clockwise) using a 7/8" open end wrench. **NOTE:** the orientation for reassembly.
6. Using a screwdriver, carefully push the valve disc up and down.
7. Clean or replace the check valve. A solvent, such as paint or varnish remover can be used to clean the check valve.
8. Apply sealant to the check valve threads. Reinstall the check valve (turn clockwise) to proper orientation.
9. Replace the pressure release tube. Tighten nuts.
10. Replace the outlet tube and tighten nuts.
11. Perform the Break-in Procedure. See **Break-in Procedure** in the *Operation* section.

Additional Service

Disassembly or service of the air compressor beyond what is covered in this manual is not recommended. If additional service is required, contact your nearest Authorized Warranty Service Center.

Accessories

Recommended accessories for use with your tool are available for purchase from your local dealer or authorized service center. If you need assistance in locating any accessory for your tool, please call 1-888-895-4549 or visit our website www.dewalt.com.

▲ WARNING: The use of any other accessory not recommended for use with this tool could be hazardous. Use only accessories rated equal to or higher than the rating of the air compressor.

Service Information

Please have the following information available for all service calls:
 Model Number _____ Serial Number _____
 Date and Place of Purchase _____

Repairs

To assure product SAFETY and RELIABILITY, repairs, maintenance and adjustment should be performed by a DeWALT factory service center, a DeWALT authorized service center or other qualified service personnel. Always use identical replacement parts.



Limited Warranty

DEWALT Industrial Tools are warranted from date of purchase.

2 Year – Limited warranty on oil-lubricated air compressor pumps.

1 Year – Limited warranty on all other air compressor components. This warranty is not transferable to subsequent owners.

DEWALT will repair or replace, without charge, at DEWALT's option, any defects due to faulty materials or workmanship. For further detail of warranty coverage and warranty repair information, call 1-(888)-895-4549 or visit dewalt.com. This warranty does not apply to accessories or damage caused where repairs have been made or attempted by others. This warranty also does not apply to merchandise sold by DEWALT which has been manufactured by and identified as the product of another company, such as gasoline engines. Such manufacturer's warranty, if any, will apply. **ANY INCIDENTAL, INDIRECT OR CONSEQUENTIAL LOSS, DAMAGE OR EXPENSE THAT MAY RESULT FROM ANY DEFECT, FAILURE OR MALFUNCTION OF THE PRODUCT IS NOT COVERED BY THIS WARRANTY.** Some states do not allow the exclusion of limitation of incidental or consequential damages, so the above limitation or exclusion may not apply to you. **IMPLIED WARRANTIES, INCLUDING THOSE OF MERCHANTABILITY OR FITNESS FOR A PARTICULAR PURPOSE, ARE LIMITED TO ONE YEAR FROM THE DATE OF ORIGINAL PURCHASE.** Some states do not allow limitations on how long an implied warranty lasts, so the above limitations may not apply to you.

What the Company Will Do: (the company) will cover parts and labor to remedy substantial defects due to materials

and workmanship during the first year of ownership, with the exceptions noted below. Parts used in repair of whole goods or accessories are warranted for the balance of the original warranty period.

What is not covered Under This Warranty? Failures by the original retail purchaser to install, maintain, and operate said equipment in accordance with standard industry practices. Modifications to the product, or tampering with components, or failure to comply with the specific recommendations of the Company set forth in the owner's manual, will render this warranty null and void. The Company shall not be liable for any repairs, replacements, or adjustments to the equipment, or any costs for labor performed by the purchaser without the Company's prior written approval. The effects of corrosion, erosion, surrounding environmental conditions, cosmetic defects, and routine maintenance items, are specifically excluded from this warranty. Routine maintenance items such as: oil, lubricants, and air filters, as well as changing oil, air filters, belt tensioning, etc... fall under the owner's responsibility. Additional exclusions include: freight damage, failures resulting from neglect, accident, or abuse, induction motors when operated from a generator, oil leaks, air leaks, oil consumption, leaky fittings, hoses, drain valve, bleeder tubes, and transfer tubes.

- The following components are considered normal wear items and are not covered after the first year of ownership: Belts, pulleys, flywheels, check valves, pressure switches, air unloaders, throttle controls, electric motors, brushes, regulators, o-rings, pressure gauges, tubing, piping, fittings, fasteners, wheels, quick couplers, gaskets, seals, air filter housings, piston rings, connecting rods, and piston seals.

- Labor, service calls, and travel charges, are not covered after the first year of ownership on stationary compressors (compressors without handles, or wheels). Repairs requiring overtime, weekend rates, or any other charges beyond the standard shop labor rate are not covered.
- Time required for orientation training for the service center to gain access to the product, or additional time due to inadequate egress.
- Damage caused by incorrect voltage, improperly wired, or failure to have a certified licensed electrician install the compressor, will render this warranty null and void.
- Damage caused from inadequate filter maintenance.
- Pump wear or valve damage caused by using oil not specified.
- Pump wear or damage caused by any oil contamination.
- Pump wear or valve damage caused by failure to follow proper maintenance guidelines.
- Operation below proper oil level or operation without oil.
- Gas Engines, if product is equipped with a gas engine, see engine manual for specific engine manufacturer's warranty coverage.

Parts purchased separately: The warranty for parts purchased separately such as: pumps, motors, etc., are as follows:

From Date of Purchase

- All single & two stage pumps 1 year
- Electric motors 90 days

- Universal motor/pump 30 days
- All other parts 30 days
- No return authorization will be issued for electrical components once items are installed.

How do You Get Service? In order to be eligible for service under this warranty you must be the original retail purchaser, and provide proof of purchase from one of the Company's dealers, distributors, or retail outlet stores. Portable compressors or components must be delivered, or shipped, to the nearest Authorized Service Center. All associated freight costs and travel charges must be borne by the consumer. Please call our toll free number 1-888-895-4549 for assistance.

THIS WARRANTY GIVES YOU SPECIFIC LEGAL RIGHTS, AND YOU MAY ALSO HAVE OTHER RIGHTS WHICH VARY FROM STATE TO STATE.

THE COMPANY MAKES NO OTHER WARRANTY OR REPRESENTATION OF ANY KIND WHATSOEVER, EXPRESSED OR IMPLIED, EXCEPT THAT OF TITLE. ALL IMPLIED WARRANTIES, INCLUDING ANY WARRANTY OF MERCHANTABILITY AND FITNESS FOR PARTICULAR PURPOSE ARE HEREBY DISCLAIMED. LIABILITY FOR CONSEQUENTIAL AND INCIDENTAL DAMAGES UNDER ANY AND ALL WARRANTIES, OTHER CONTRACTS, NEGLIGENCE, OR OTHER TORTS IS EXCLUDED TO THE EXTENT EXCLUSION IS PERMITTED BY LAW.



FREE WARNING LABEL REPLACEMENT: If your warning labels become illegible or are missing, call 1-888-895-4549 for a free replacement.



▲ WARNING	▲ ADVERTENCIA	▲ AVERTISSEMENT
<p>▲ RISK OF FIRE OR EXPLOSION. ALWAYS USE WITH PROPER INSTRUCTIONS. DO NOT OPERATE COMPRESSOR UNTIL YOU ARE CERTAIN OF THE PROPER USE OF THE UNIT. ALWAYS USE WITH PROPER INSTRUCTIONS. DO NOT OPERATE COMPRESSOR UNTIL YOU ARE CERTAIN OF THE PROPER USE OF THE UNIT. ALWAYS USE WITH PROPER INSTRUCTIONS. DO NOT OPERATE COMPRESSOR UNTIL YOU ARE CERTAIN OF THE PROPER USE OF THE UNIT.</p>	<p>▲ RIESGO DE INCENDIO O EXPLOSIÓN. SIEMPRE USAR CON LAS INSTRUCCIONES CORRECTAS. NO OPERAR EL COMPRESOR DE AER. HASTA VERIFICAR QUE SE USAN LAS INSTRUCCIONES CORRECTAS. SIEMPRE USAR CON LAS INSTRUCCIONES CORRECTAS. NO OPERAR EL COMPRESOR DE AER. HASTA VERIFICAR QUE SE USAN LAS INSTRUCCIONES CORRECTAS. SIEMPRE USAR CON LAS INSTRUCCIONES CORRECTAS. NO OPERAR EL COMPRESOR DE AER. HASTA VERIFICAR QUE SE USAN LAS INSTRUCCIONES CORRECTAS.</p>	<p>▲ RISK OF FIRE OR EXPLOSION. ALWAYS USE WITH PROPER INSTRUCTIONS. DO NOT OPERATE COMPRESSOR UNTIL YOU ARE CERTAIN OF THE PROPER USE OF THE UNIT. ALWAYS USE WITH PROPER INSTRUCTIONS. DO NOT OPERATE COMPRESSOR UNTIL YOU ARE CERTAIN OF THE PROPER USE OF THE UNIT. ALWAYS USE WITH PROPER INSTRUCTIONS. DO NOT OPERATE COMPRESSOR UNTIL YOU ARE CERTAIN OF THE PROPER USE OF THE UNIT.</p>
<p>▲ RISK OF PERSONAL INJURY. ALWAYS WEAR SAFETY GLASSES. NEVER OPERATE COMPRESSOR WITH MATERIALS THAT ARE NOT LISTED IN THE OPERATING INSTRUCTIONS. NEVER OPERATE COMPRESSOR WITH MATERIALS THAT ARE NOT LISTED IN THE OPERATING INSTRUCTIONS. NEVER OPERATE COMPRESSOR WITH MATERIALS THAT ARE NOT LISTED IN THE OPERATING INSTRUCTIONS.</p>	<p>▲ RIESGO DE LESIONES. LLEVE SIEMPRE GAFAS DE SEGURIDAD ANTES DE MANEJAR EL COMPRESOR. NUNCA OPERAR EL COMPRESOR CON MATERIALES QUE NO SE ENLISTEN EN LAS INSTRUCCIONES DE USO. NUNCA OPERAR EL COMPRESOR CON MATERIALES QUE NO SE ENLISTEN EN LAS INSTRUCCIONES DE USO. NUNCA OPERAR EL COMPRESOR CON MATERIALES QUE NO SE ENLISTEN EN LAS INSTRUCCIONES DE USO.</p>	<p>▲ RISK OF PERSONAL INJURY. ALWAYS WEAR SAFETY GLASSES. NEVER OPERATE COMPRESSOR WITH MATERIALS THAT ARE NOT LISTED IN THE OPERATING INSTRUCTIONS. NEVER OPERATE COMPRESSOR WITH MATERIALS THAT ARE NOT LISTED IN THE OPERATING INSTRUCTIONS. NEVER OPERATE COMPRESSOR WITH MATERIALS THAT ARE NOT LISTED IN THE OPERATING INSTRUCTIONS.</p>
<p>▲ RISK OF BURSTING. BEFORE STARTING THE COMPRESSOR, PULL THE PIN OF THE SAFETY VALVE. ALWAYS WEAR SAFETY GLASSES. NEVER OPERATE COMPRESSOR WITH MATERIALS THAT ARE NOT LISTED IN THE OPERATING INSTRUCTIONS. NEVER OPERATE COMPRESSOR WITH MATERIALS THAT ARE NOT LISTED IN THE OPERATING INSTRUCTIONS. NEVER OPERATE COMPRESSOR WITH MATERIALS THAT ARE NOT LISTED IN THE OPERATING INSTRUCTIONS.</p>	<p>▲ RIESGO DE ESTALLIDO. ANTES DE ACTIVAR EL COMPRESOR, RETIRE EL PIN DE LA VALVULA DE SEGURIDAD. SIEMPRE USAR GAFAS DE SEGURIDAD ANTES DE MANEJAR EL COMPRESOR. NUNCA OPERAR EL COMPRESOR CON MATERIALES QUE NO SE ENLISTEN EN LAS INSTRUCCIONES DE USO. NUNCA OPERAR EL COMPRESOR CON MATERIALES QUE NO SE ENLISTEN EN LAS INSTRUCCIONES DE USO. NUNCA OPERAR EL COMPRESOR CON MATERIALES QUE NO SE ENLISTEN EN LAS INSTRUCCIONES DE USO.</p>	<p>▲ RISK OF BURSTING. BEFORE STARTING THE COMPRESSOR, PULL THE PIN OF THE SAFETY VALVE. ALWAYS WEAR SAFETY GLASSES. NEVER OPERATE COMPRESSOR WITH MATERIALS THAT ARE NOT LISTED IN THE OPERATING INSTRUCTIONS. NEVER OPERATE COMPRESSOR WITH MATERIALS THAT ARE NOT LISTED IN THE OPERATING INSTRUCTIONS. NEVER OPERATE COMPRESSOR WITH MATERIALS THAT ARE NOT LISTED IN THE OPERATING INSTRUCTIONS.</p>
<p>▲ RISK OF ELECTRICAL SHOCK. ALWAYS DISCONNECT THE POWER FROM ALL HOSES PRIOR TO TANK CLEANING. ALWAYS DISCONNECT THE POWER FROM ALL HOSES PRIOR TO TANK CLEANING. ALWAYS DISCONNECT THE POWER FROM ALL HOSES PRIOR TO TANK CLEANING.</p>	<p>▲ RIESGO DE CHOQUE ELECTRICO. SIEMPRE DESCONECTAR EL ALIMENTADO ANTES DE LIMPIAR EL TANQUE O LOS MANGUEROS. SIEMPRE DESCONECTAR EL ALIMENTADO ANTES DE LIMPIAR EL TANQUE O LOS MANGUEROS. SIEMPRE DESCONECTAR EL ALIMENTADO ANTES DE LIMPIAR EL TANQUE O LOS MANGUEROS.</p>	<p>▲ RISK OF ELECTRICAL SHOCK. ALWAYS DISCONNECT THE POWER FROM ALL HOSES PRIOR TO TANK CLEANING. ALWAYS DISCONNECT THE POWER FROM ALL HOSES PRIOR TO TANK CLEANING. ALWAYS DISCONNECT THE POWER FROM ALL HOSES PRIOR TO TANK CLEANING.</p>

GLOSSARY

CFM: Cubic feet per minute.

SCFM: Standard cubic feet per minute; a unit of measure of air delivery.

PSI: Pounds per square inch; a unit of measure of pressure.

Cut-in pressure: Factory set low pressure point that starts the compressor to repressurize the tank to a higher pressure.

Cut-out pressure: Factory set high pressure point that stops the compressor from increasing the pressure in the tank above a certain level.

Well-ventilated: A means of providing fresh air in exchange for dangerous exhaust or vapors.

Dedicated circuit: An electrical circuit reserved for the exclusive use of the air compressor.

ASME: American Society of Mechanical Engineers. Indicates that the components are manufactured, tested and inspected to the specifications set by ASME.

CSA: Canadian Standards Association

 Indicates that the products that have this marking have been manufactured, tested and inspected to standards that are set by CSA.

Canadian Standards Association (USA): Indicates that the products that have this marking have been manufactured, tested and inspected to standards that are set by CSA. These products also conform to U.L. standard 1450.

California Code: Unit may comply with California Code 462 (l) (2) (M) (2). Specification/model label is on the side of the air tank on units that comply with California Code.

English

Troubleshooting Guide

This section provides a list of the more frequently encountered malfunctions, their causes and corrective actions. The operator or maintenance personnel can perform some corrective actions, and others may require the assistance of a qualified DEWALT technician or your dealer.

Problem	Code
Air leaks	1
Air leaks in air tank or at air tank welds	2
Air leaks between head and valve plate.....	3
Air leaks from safety valve.....	4
Compressor is not supplying enough air to operate accessories	1, 5, 6, 7, 9, 10
Restricted air intake.....	9
Oil in discharge air.....	9, 19, 31
Knocking Noise	4, 10, 11, 12, 13, 14
Excessive belt wear.....	10, 11, 14, 15
Squealing sound.....	10
Moisture in pump crankcase.....	1, 3, 8, 17, 18, 19, 20, 21, 22
Excessive current draw	14, 23, 24
Compressor won't start in cold temperatures	17, 31, 32
Compressor stalls.....	25, 26, 27
Overheating	24, 29, 30

Troubleshooting Codes

CODE	POSSIBLE CAUSE	POSSIBLE SOLUTION
1	Fittings are not tight.	Tighten fittings where air can be heard escaping. Check fittings with soapy water solution. DO NOT OVERTIGHTEN.
2	Defective air tank.	Air tank must be replaced. Do not repair the leak. ▲WARNING: Risk of bursting. Do not drill into, weld or otherwise modify air tank or it will weaken. The air tank can rupture or explode.
3	Leaking seals.	Contact a DEWALT factory service center or a DEWALT authorized service center.
4	Defective safety valve.	Operate safety valve manually by pulling on ring. If valve still leaks, it must be replaced.
5	Prolonged excessive use of air.	Decrease amount of air usage.
6	Compressor is not large enough for accessory.	Check the accessory air requirement. If it is higher than the SCFM or pressure supplied by your air compressor, a larger compressor is needed to operate accessory.
7	Hole in air hose.	Check and replace air hose, if required.
8	Unit operating in damp or humid conditions.	Move unit to a dry, well ventilated area.
9	Restricted air intake filter.	Clean or replace air intake filter.
10	Loose belt.	Check belt tension, see Adjusting Belt Tension under <i>Maintenance</i> .
11	Loose pulley.	Tighten pulley set screw, torque to 60-80 in.-lbs. (6.8-9.0 Nm).
12	Loose flywheel.	Tighten flywheel screw, torque to 10-12 ft.-lbs. (13.6-16.3 Nm).
13	Carbon build-up in pump.	Contact a DEWALT factory service center or a DEWALT authorized service center.

CODE	POSSIBLE CAUSE	POSSIBLE SOLUTION
14	Belt too tight.	Check belt tension, see Adjusting Belt Tension under <i>Maintenance</i> .
15	Pulley misalignment.	See Motor Pulley/Flywheel Alignment under <i>Maintenance</i> .
16	Pump oil is low.	Add semi-synthetic blend, non-detergent air compressor oil to pump. See Compressor Pump Oil under <i>Maintenance</i> .
17	Detergent type oil being used in pump.	Drain oil and refill pump with semi-synthetic blend non-detergent air compressor oil.
18	Extremely light duty cycles.	Run unit for longer duty cycles.
19	Piston rings damaged or worn.	Contact a DEWALT factory service center or a DEWALT authorized service center.
20	Cylinder or piston damaged or worn.	Contact a DEWALT factory service center or a DEWALT authorized service center.
21	Compressor cylinder finish worn.	Contact a DEWALT factory service center or a DEWALT authorized service center.
22	Water in pump oil.	Drain oil and refill pump with semi-synthetic blend non-detergent air compressor oil.
23	Low voltage/motor overload.	Check that power supply is adequate and that compressor is on a dedicated circuit. If compressor is connected to a circuit protected by a fuse, use time delay fuses.
24	Restricted air passages.	Inspect and replace transfer tubes or check valve, as required.
25	Low voltage motor.	Furnish adequate power.
26	Bad check valve.	Replace check valve.



CODE	POSSIBLE CAUSE	POSSIBLE SOLUTION
27	Seized pump.	Contact a DeWALT factory service center or a DeWALT authorized service center.
28	Oil level too high.	Reduce to proper level. See Compressor Pump Oil under <i>Maintenance</i> .
29	Poor ventilation.	Relocate compressor to an area with cool, dry, well circulated air, at least 12 in. from nearest wall.
30	Dirty cooling surfaces.	Clean all cooling surfaces thoroughly.
31	Too much back pressure in tank.	Open drain valve when starting motor.
32	Compressor too cold.	Move compressor to a warmer location.



*For product, service or warranty information contact us at:
Para el producto, servicio o información sobre la garantía contacte con nosotros en:
Pour les produits, services ou informations sur la garantie nous contacter à:*

1-888-895-4549

www.DEWALT.com

MAT Industries, LLC, Long Grove, IL 60047

Copyright © 2018 DEWALT. DEWALT® and the DEWALT Logo are trademarks of the DEWALT Industrial Tool Co., or an affiliate thereof and are used under license.

Copyright © 2018 DEWALT. DEWALT® y el logo de DEWALT son marcas registradas de DEWALT Industrial Tool Co. o una empresa filial, y se utilizan bajo licencia.

Copyright © 2018 DEWALT. DEWALT® et le logo de DEWALT sont des marques déposées de DEWALT Industrial Tool Co. ou une société affiliée et sont utilisés sous licence.

The yellow/black color scheme is a trademark for DEWALT power tools & accessories.

El gráfico de color negro y amarillo es una marca registrada para las herramientas eléctricas y los accesorios de DEWALT.

L'agencement de couleurs jaune et noir est une marque de commerce des outils électriques et accessoires DEWALT.