

# Instruction manual

## Laminate Trimmer



MODEL  
310

### **IMPORTANT**

*Please make certain that the person who is to use this equipment carefully reads and understands these instructions before starting operations.*

The Model and Serial No. plate is located on the main housing of the tool. Record these numbers in the spaces below and retain for future reference.

Model No. \_\_\_\_\_

Type \_\_\_\_\_

Serial No. \_\_\_\_\_

To learn more about Porter-Cable  
visit our website at:

<http://www.porter-cable.com>

**PORTER-CABLE**  
PROFESSIONAL POWER TOOLS

## TABLE OF CONTENTS

<b>IMPORTANT SAFETY INSTRUCTIONS</b> .....	2
<b>SAFETY GUIDELINES</b> .....	3
<b>GENERAL SAFETY RULES</b> .....	4
<b>ADDITIONAL SPECIFIC SAFETY RULES</b> .....	6
<b>CARTON CONTENTS</b> .....	9
<b>FUNCTIONAL DESCRIPTION</b> .....	9
<b>OPERATION</b> .....	9
<b>TROUBLESHOOTING</b> .....	13
<b>MAINTENANCE</b> .....	14
<b>SERVICE</b> .....	15
<b>ACCESSORIES</b> .....	15
<b>WARRANTY</b> .....	16
<b>ESPAÑOL</b> .....	17
<b>FRANÇAISE</b> .....	31
<b>SERVICE CENTER LOCATIONS</b> .....	back cover

## IMPORTANT SAFETY INSTRUCTIONS

**▲WARNING** Read and understand all warnings and operating instructions before using any tool or equipment. When using tools or equipment, basic safety precautions should always be followed to reduce the risk of personal injury. Improper operation, maintenance or modification of tools or equipment could result in serious injury and property damage. There are certain applications for which tools and equipment are designed. Porter-Cable strongly recommends that this product NOT be modified and/or used for any application other than for which it was designed.

If you have any questions relative to its application DO NOT use the product until you have written Porter-Cable and we have advised you.

Online contact form at [www.porter-cable.com](http://www.porter-cable.com)

Postal Mail: Technical Service Manager  
Porter-Cable Corporation  
4825 Highway 45 North  
Jackson, TN 38305

Information regarding the safe and proper operation of this tool is available from the following sources:

Power Tool Institute  
1300 Sumner Avenue, Cleveland, OH 44115-2851  
[www.powertoolinstitute.org](http://www.powertoolinstitute.org)

National Safety Council  
1121 Spring Lake Drive, Itasca, IL 60143-3201

American National Standards Institute, 25 West 43rd Street, 4 floor, New York, NY 10036 [www.ansi.org](http://www.ansi.org) ANSI 01.1 Safety Requirements for Woodworking Machines, and the U.S. Department of Labor regulations [www.osha.gov](http://www.osha.gov)

**SAVE THESE INSTRUCTIONS!**

## SAFETY GUIDELINES - DEFINITIONS

It is important for you to read and understand this manual. The information it contains relates to protecting YOUR SAFETY and PREVENTING PROBLEMS. The symbols below are used to help you recognize this information.



### **▲ DANGER**

indicates an imminently hazardous situation which, if not avoided, will result in death or serious injury.

### **▲ WARNING**

indicates a potentially hazardous situation which, if not avoided, could result in death or serious injury.

### **▲ CAUTION**

indicates a potentially hazardous situation which, if not avoided, may result in minor or moderate injury.

### **CAUTION**

used without the safety alert symbol indicates a potentially hazardous situation which, if not avoided, may result in property damage.

## CALIFORNIA PROPOSITION 65

### **▲ WARNING**

Some dust created by power sanding, sawing, grinding, drilling, and other construction activities contains chemicals known (to the State of California) to cause cancer, birth defects or other reproductive harm. Some examples of these chemicals are:

- lead from lead-based paints
- crystalline silica from bricks and cement and other masonry products
- arsenic and chromium from chemically-treated lumber

Your risk from these exposures varies, depending on how often you do this type of work. To reduce your exposure to these chemicals: work in a well ventilated area, and work with approved safety equipment, always wear NIOSH/OSHA approved, properly fitting face mask or respirator when using such tools.

# GENERAL SAFETY RULES

## **⚠️ WARNING**

Read all instructions. Failure to follow all instructions listed below may result in electric shock, fire and/or serious injury. The term "power tool" in all of the warnings listed below refers to your mains-operated (corded) power tool or battery-operated (cordless) power tool.



SAVE THESE INSTRUCTIONS

### 1) Work area safety

- a) **Keep work area clean and well lit.** Cluttered or dark areas invite accidents.
- b) **Do not operate power tools in explosive atmospheres, such as in the presence of flammable liquids, gases or dust.** Power tools create sparks which may ignite the dust or fumes.
- c) **Keep children and bystanders away while operating a power tool.** Distractions can cause you to lose control.

### 2) Electrical safety

- a) **Power tool plugs must match the outlet. Never modify the plug in any way. Do not use any adapter plugs with earthed (grounded) power tools.** Unmodified plugs and matching outlets will reduce risk of electric shock.
- b) **Avoid body contact with earthed or grounded surfaces such as pipes, radiators, ranges and refrigerators.** There is an increased risk of electric shock if your body is earthed or grounded.
- c) **Do not expose power tools to rain or wet conditions.** Water entering a power tool will increase the risk of electric shock.
- d) **Do not abuse the cord. Never use the cord for carrying, pulling or unplugging the power tool. Keep cord away from heat, oil, sharp edges or moving parts.** Damaged or entangled cords increase the risk of electric shock.
- e) **When operating a power tool outdoors, use an extension cord suitable for outdoor use.** Use of a cord suitable for outdoor use reduces the risk of electric shock.

### 3) Personal safety

- a) **Stay alert, watch what you are doing and use common sense when operating a power tool. Do not use a power tool while you are tired or under the influence of drugs, alcohol or medication.** A moment of inattention while operating power tools may result in serious personal injury.
- b) **Use safety equipment. Always wear eye protection.** Safety equipment such as dust mask, non-skid safety shoes, hard hat, or hearing protection used for appropriate conditions will reduce personal injuries.
- c) **Avoid accidental starting. Ensure the switch is in the off-position before plugging in.** Carrying power tools with your finger on the switch or plugging in power tools that have the switch on invites accidents.

## GENERAL SAFETY RULES continued

- d) **Remove any adjusting key or wrench before turning the power tool on.** A wrench or a key left attached to a rotating part of the power tool may result in personal injury.
- e) **Do not overreach. Keep proper footing and balance at all times.** This enables better control of the power tool in unexpected situations.
- f) **Dress properly. Do not wear loose clothing or jewelry. Keep your hair, clothing and gloves away from moving parts.** Loose clothes, jewelry or long hair can be caught in moving parts.
- g) **If devices are provided for the connection of dust extraction and collection facilities, ensure these are connected and properly used.** Use of these devices can reduce dust-related hazards.

### 4) Power tool use and care

- a) **Do not force the power tool. Use the correct power tool for your application.** The correct power tool will do the job better and safer at the rate for which it was designed.
- b) **Do not use the power tool if the switch does not turn it on and off.** Any power tool that cannot be controlled with the switch is dangerous and must be repaired.
- c) **Disconnect the plug from the power source before making any adjustments, changing accessories, or storing power tools.** Such preventive safety measures reduce the risk of starting the power tool accidentally.
- d) **Store idle power tools out of the reach of children and do not allow persons unfamiliar with the power tool or these instructions to operate the power tool.** Power tools are dangerous in the hands of untrained users.
- e) **Maintain power tools. Check for misalignment or binding of moving parts, breakage of parts and any other condition that may affect the power tools operation. If damaged, have the power tool repaired before use.** Many accidents are caused by poorly maintained power tools.
- f) **Keep cutting tools sharp and clean.** Properly maintained cutting tools with sharp cutting edges are less likely to bind and are easier to control.
- g) **Use the power tool, accessories and tool bits etc., in accordance with these instructions and in the manner intended for the particular type of power tool, taking into account the working conditions and the work to be performed.** Use of the power tool for operations different from those intended could result in a hazardous situation.











### 5) Service

- a) **Have your power tool serviced by a qualified repair person using only identical replacement parts.** This will ensure that the safety of the power tool is maintained.

## ADDITIONAL SPECIFIC SAFETY RULES

- 1. Use clamps or other practical way to secure and support the workpiece to a stable platform.** Holding the work by hand or against your body is unstable and may lead to loss of control.
- 2. Tighten Collet nut securely to prevent the bit from slipping. Never tighten collet nut without a bit. Never adjust depth of cut while motor is running.** A slip at this time may cause personal injury, or damage to cutter or workpiece.
- 3. Be sure cord set is free and will not “hang up” during trimming operations.** A tangled cord could result in personal injury, or damage to work.
- 4. Keep hands clear of cutter when motor is running.** A moment of inattention while operating power tools may result in serious personal injury.
- 5. Maintain firm grip on trimmer when starting motor to resist starting torque.** Loss of control could result, causing personal injury, or damage to work.
- 6. Keep cutter clear of all foreign objects while motor is running. Provide clearance under workpiece for the bit when through-cutting.** This enables better control of the power tool in unexpected situations.
- 7. Be sure motor has completely stopped before setting trimmer down between operations.** Such preventive safety measures reduce the risk of personal injury, or damage to work.
- 8. Never touch bit immediately after use.** It may be extremely hot.
- 9. Do not use Laminate Trimmer motor without the Laminate Trimmer Base installed.** Loss of control could result, causing personal injury, or damage to work.
- 10. Wear eye and hearing protection. Always use safety glasses.** Everyday eyeglasses are NOT safety glasses. USE CERTIFIED SAFETY EQUIPMENT. Eye protection equipment should comply with ANSI Z87.1 standards. Hearing equipment should comply with ANSI S3.19 standards.
- 11.  **WARNING** Use of this tool can generate and disburse dust or other airborne particles, including wood dust, crystalline silica dust and asbestos dust.** Direct particles away from face and body. Always operate tool in well ventilated area and provide for proper dust removal. Use dust collection system wherever possible. Exposure to the dust may cause serious and permanent respiratory or other injury, including silicosis (a serious lung disease), cancer, and death. Avoid breathing the dust, and avoid prolonged contact with dust. Allowing dust to get into your mouth or eyes, or lay on your skin may promote absorption of harmful material. Always use properly fitting NIOSH/OSHA approved respiratory protection appropriate for the dust exposure, and wash exposed areas with soap and water.

**SAVE THESE INSTRUCTIONS!**

<b>SYMBOL</b>	<b>DEFINITION</b>
V	volts
A	amperes
Hz	hertz
W	watts
kW	kilowatts
F	farads
$\mu\text{F}$	microfarads
l	litres
g	grams
kg	kilograms
bar	bars
Pa	pascals
h	hours
min	minutes
s	seconds
$n_0$	no-load speed
.../min or ...min <sup>-1</sup>	Revolutions or reciprocations per minute
 or d.c.	direct current
 or a.c.	alternating current
2 	two-phase alternating current
2N 	two-phase alternating current with neutral
3 	three-phase alternating current
3N 	three-phase alternating current with neutral
 A	rated current of the appropriate fuse-link in amperes
 X	time-lag miniature fuse-link where X is the symbol for the time/current characteristic, as given in IEC 60127
	protective earth
	class II tool
IPXX	IP symbol

## MOTOR

Many Porter-Cable tools will operate on either D.C., or single phase 25 to 60 cycle A.C. current and voltage within plus or minus 5 percent of that shown on the specification plate on the tool. Several models, however, are designed for A.C. current only. Refer to the specification plate on your tool for proper voltage and current rating.

**CAUTION** Do not operate your tool on a current on which the voltage is not within correct limits. Do not operate tools rated A.C. only on D.C. current. To do so may seriously damage the tool.

## EXTENSION CORD SELECTION

If an extension cord is used, make sure the conductor size is large enough to prevent excessive voltage drop which will cause loss of power and possible motor damage. A table of recommended extension cord sizes will be found in this section. This table is based on limiting line voltage drop to 5 volts (10 volts for 230 volts) at 150% of rated amperes.

If an extension cord is to be used outdoors, it must be marked with the suffix W-A or W following the cord type designation. For example – SJTW-A to indicate it is acceptable for outdoor use.

RECOMMENDED EXTENSION CORD SIZES FOR USE WITH PORTABLE ELECTRIC TOOLS

		Length of Cord in Feet									
		115V	25 Ft.	50 Ft.	100 Ft.	150 Ft.	200 Ft.	250 Ft.	300 Ft.	400 Ft.	500 Ft.
		230V	50 Ft.	100 Ft.	200 Ft.	300 Ft.	400 Ft.	500 Ft.	600 Ft.	800 Ft.	1000 Ft.
Nameplate Ampere Rating	0-2	18	18	18	16	16	14	14	12	12	
	2-3	18	18	16	14	14	12	12	10	10	
	3-4	18	18	16	14	12	12	10	10	8	
	4-5	18	18	14	12	12	10	10	8	8	
	5-6	18	16	14	12	10	10	8	8	6	
	6-8	18	16	12	10	10	8	6	6	6	
	8-10	18	14	12	10	8	8	6	6	4	
	10-12	16	14	10	8	8	6	6	4	4	
	12-14	16	12	10	8	6	6	6	4	2	
	14-16	16	12	10	8	6	6	4	4	2	
	16-18	14	12	8	8	6	4	4	2	2	
18-20	14	12	8	6	6	4	4	2	2		

**SAVE THESE INSTRUCTIONS!**



## CARTON CONTENTS

1. Trimmer motor
2. Trimmer base
3. Open-end wrenches (2)

## FUNCTIONAL DESCRIPTION

### FOREWORD

The Porter-Cable Model 310 Laminate Trimmer is designed for trimming laminated plastics, phenolics and other similar materials having a bonding agent too hard to be trimmed with ordinary tools.

## ASSEMBLY

**NOTE: This tool is shipped completely assembled. No assembly time or tools are required.**

## OPERATION

### SELECTING THE BIT

The Model 310 is equipped with a 1/4" diameter collet to accept laminate trimming bits with 1/4" diameter shanks.

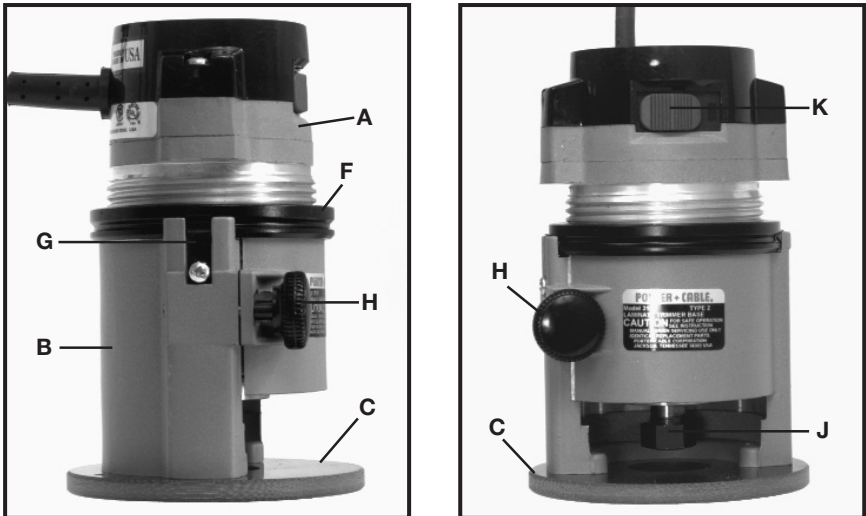

Fig. 1

**A** – Motor Unit  
**B** – Base Unit  
**C** – Sub-Base  
**F** – Depth Adjusting Ring

**G** – Ring Spring  
**H** – Clamp Knob  
**J** – Collet Nut  
**K** – Switch

## TO INSTALL BIT

1. **▲WARNING** **DISCONNECT TOOL FROM POWER SOURCE.**
2. Remove power unit from base unit as follows:
  - a. Loosen clamping knob (H) Fig. 1.
  - b. Grasp power unit (A) Fig. 1, and pull straight up and out of the base unit (B) Fig. 1. This will also release the depth adjusting ring (F) Fig. 1, from ring springs (G) Fig. 1.
3. Lay power unit on bench with collet toward you.
4. Clean and insert shank of bit into collet until end of shank bottoms. Then pull out approximately  $\frac{1}{16}$ ".
5. Place one wrench on flats of shaft directly above collet nut (J) Fig. 1. Let far end of wrench rest on bench to your RIGHT.
6. Place other wrench on collet nut (J) Fig. 1, and turn clockwise to tighten. **TIGHTEN SECURELY.**

## TO REMOVE THE BIT

**▲WARNING** **NEVER TOUCH BIT IMMEDIATELY AFTER USE, AS IT MAY BE EXTREMELY HOT.**

1. Repeat Steps 1 through 3 under TO INSTALL BIT.
2. Place one wrench on flats of shaft directly above collet nut (J) Fig. 1. Let far end of wrench rest on bench to your LEFT.
3. Place other wrench on collet nut and turn counterclockwise and loosen only enough to allow removal of bit. **NEVER TIGHTEN COLLET NUT WITHOUT BIT IN COLLET.** This may allow collet to deform and weaken clamping ability.

## ADJUSTING BIT EXPOSURE

1. **▲WARNING** **DISCONNECT TOOL FROM POWER SOURCE.**
  2. With power unit removed from base unit, turn depth adjusting ring to position ring approximately six threads from top of power unit.
  3. Insert power unit into base unit, aligning one of the grooves in the motor housing with the pin protruding from inner wall of the base. Proceed until ring springs snap into groove in depth adjusting ring.
  4. Viewing power unit from top, turn depth adjusting ring clockwise to decrease depth of cut, or counterclockwise to increase depth of cut.
- NOTE:** For convenience in making slight adjustments, a marker can be found on the base next to the ring spring. The depth adjusting ring is graduated with eight equally spaced lines each representing  $\frac{1}{64}$ " change in depth of cut, (when rotated in relation to the marker). One complete turn of the ring changes the depth of cut  $\frac{1}{8}$ ".
5. **USING ONLY FINGER PRESSURE, TIGHTEN CLAMPING KNOB.**
  6. Make a practice cut on a piece of scrap material (see USING A LAMINATE TRIMMER).

## USING A LAMINATE TRIMMER

1. Material to be trimmed must overhang the base material by a least  $\frac{1}{8}$ ".
2. **⚠ WARNING** Always wear ansi Z87.1 safety glasses while operating a laminate trimmer.
3. **⚠ WARNING** DISCONNECT TOOL FROM POWER SOURCE.
4. Firmly grasp motor housing being sure switch is in the "OFF" position.
5. Verify bit is clear of foreign objects and cord will not "hang up" on any obstructions.
6. Be sure workpiece is firmly held in place. Use clamps where necessary to secure workpiece.
7. Plug in power supply cord. Be alert to resist starting torque of motor. Turn motor "ON".
8. Allow motor to reach "full speed". Place base of trimmer on surface to be trimmed and feed into work until bit pilot contacts base materials. When guiding on a previously laminated surface, always wax or lubricate the area that the trimmer will guide against.
9. Feed from left to right with smooth steady motion.
10. At completion of trimming operation, turn switch "OFF". Allow motor to come to a complete stop before laying trimmer down.

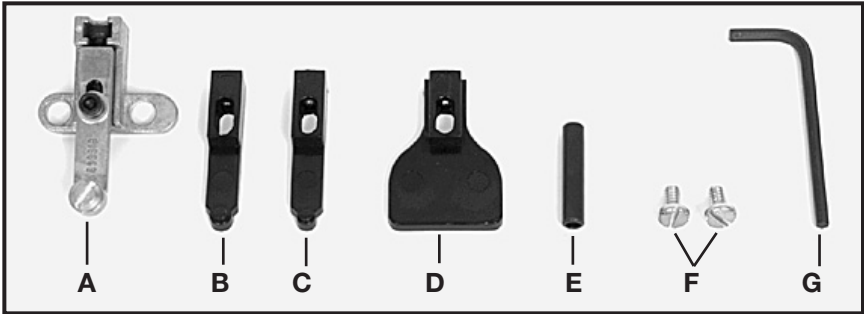

Fig. 2

## 73100 EDGE GUIDE KIT

The Model 73100 Edge Guide Kit is available (as an accessory), for use with the Model 310 trimmer. The 73100 is designed for use with non-piloted bits, on curved or straight applications. Non-piloted bits can produce a 90° straight cut, a 10° bevel cut, or a 22° bevel cut. The kit contains the parts shown in Fig. 2. Install the 73100 guide as follows:

- A – Base and roller guide - for use with non-piloted bits
- B – Edge guide – for flush trimming
- C – Edge guide – for bevel trimming
- D – Straight edge guide – for straight trimming
- E – Guide setting gauge
- F – Mounting screws
- G – Wrench

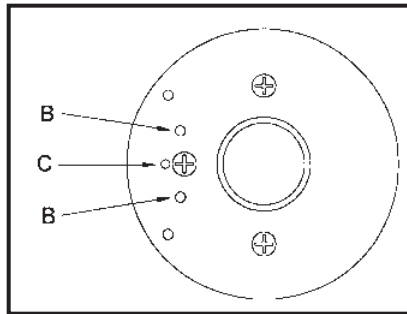

Fig. 3

## ASSEMBLING AND ADJUSTING BASE AND ROLLER (73100)

1. **⚠ WARNING DISCONNECT TOOL FROM POWER SOURCE.**
2. Remove power unit from base unit (see TO INSTALL BIT), and install the bit.
3. Position the base and roller guide assembly (A) Fig. 2, to the base unit. The alignment pin on the back of the guide base fits into hole (C) Fig. 3.
4. Place the two mounting screws (F) Fig. 2, through the guide base and thread into sub-base holes (B) Fig. 3. Tighten screws firmly.
5. Install motor to base and adjust bit exposure (see ADJUSTING BIT EXPOSURE).

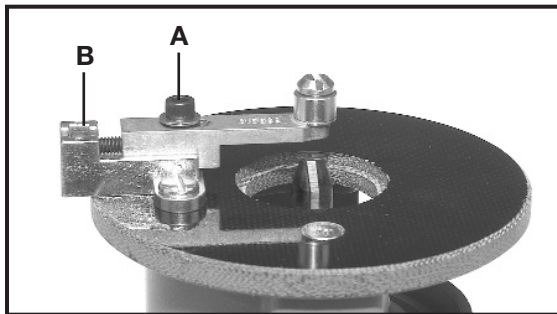

Fig. 4

**NOTE:** For FLUSH CUTS, adjust bit exposure so that the straight cutting edge (of bit) will engage the work. For BEVEL CUTS, adjust bit exposure so that the angled cutting edge (of bit), will engage the work.

6. Align roller guide with bit by loosening locking screw (A) Fig. 4, and turning adjusting screw (B) Fig. 4, (with hex wrench provided), until guide is in desired location.

**NOTE:** For FLUSH CUTS, align roller with straight portion of bit. For BEVEL CUTS, adjust roller to expose the desired amount of the bevel bit.

7. Tighten locking screw and make a trial cut on scrap material to check alignment. Readjust if necessary.

## FLUSH TRIMMING

1. **⚠ WARNING** **DISCONNECT TOOL FROM POWER SOURCE.**
2. Attach base and guide to trimmer as outlined under ASSEMBLING AND ADJUSTING BASE AND ROLLER.
3. Remove roller guide and replace with flush trimming guide (B) Fig. 2. This guide may be identified by the molded on letter “F”. The stud on the end of this guide must face toward the trimmer base.
4. Install guide setting gauge (E) Fig. 2, into trimmer collet (see TO INSTALL BIT). Install trimmer motor to base. Adjust guide so that hole in end of gauge may be positioned over the guide stud.
5. Remove guide setting gauge from trimmer and install flush trimming bit.
6. Adjust depth of cut so that the straight portion of the bit extends below the trimmer base at least the thickness of the material to be trimmed.
7. Make a trial cut on scrap material. Readjust if necessary.

## BEVEL TRIMMING

1. Follow Steps 1 through 5 under FLUSH TRIMMING, except install bevel trimming guide (C) Fig. 2. This guide is identified by the letter “B” molded onto it.
2. Adjust depth of cut so that only the bevel portion of the bit extends below trimmer base at least the thickness of the material to be trimmed.
3. Make a trial cut on scrap material to check alignment. Readjust if necessary.

## USING STRAIGHT EDGE GUIDE

The straight edge guide (D) Fig. 2, maybe used with either bit for trimming straight edges.

Assemble it to the guide base and adjust similar to the other guides.

## TROUBLESHOOTING

For assistance with your tool, visit our website at [www.porter-cable.com](http://www.porter-cable.com) for a list of service centers or call the Porter-Cable help line at 1-800-487-8665.

## MAINTENANCE

### KEEP TOOL CLEAN

Periodically blow out all air passages with dry compressed air. All plastic parts should be cleaned with a soft damp cloth. NEVER use solvents to clean plastic parts. They could possibly dissolve or otherwise damage the material.

**▲ WARNING** Wear ANSI Z87.1 safety glasses while using compressed air.

### FAILURE TO START

Should your tool fail to start, check to make sure the prongs on the cord plug are making good contact in the outlet. Also, check for blown fuses or open circuit breakers in the line.

### LUBRICATION

This tool has been lubricated with a sufficient amount of high grade lubricant for the life of the unit under normal operating conditions. No further lubrication is necessary.

### BRUSH INSPECTION (If applicable)

For your continued safety and electrical protection, brush inspection and replacement on this tool should ONLY be performed by an AUTHORIZED PORTER-CABLE SERVICE STATION or a PORTER-CABLE•DELTA FACTORY SERVICE CENTER.

At approximately 100 hours of use, take or send your tool to your nearest authorized Porter-Cable Service Station to be thoroughly cleaned and inspected. Have worn parts replaced and lubricated with fresh lubricant. Have new brushes installed, and test the tool for performance.

Any loss of power before the above maintenance check may indicate the need for immediate servicing of your tool. DO NOT CONTINUE TO OPERATE TOOL UNDER THIS CONDITION. If proper operating voltage is present, return your tool to the service station for immediate service.

## SERVICE

### REPLACEMENT PARTS

When servicing use only identical replacement parts. For a service parts list or to learn more about Porter-Cable visit our website at [www.porter-cable.com](http://www.porter-cable.com)

### SERVICE AND REPAIRS

All quality tools will eventually require servicing, or replacement of parts due to wear from normal use. For assistance with your tool, visit our website at [www.porter-cable.com](http://www.porter-cable.com) for a list of service centers or call the Customer Care Department at **1-800-487-8665**. All repairs made by our service centers are fully guaranteed against defective material and workmanship. We cannot guarantee repairs made or attempted by others.

Should you have any questions about your tool, feel free to write us at any time. In any communications, please give all information shown on the nameplate of your tool (model number, type, serial number, etc.).

## ACCESSORIES

A complete line of accessories is available from your Porter-Cable•Delta Supplier, Porter-Cable•Delta Factory Service Centers, and Porter-Cable Authorized Service Stations. Please visit our Web Site [www.porter-cable.com](http://www.porter-cable.com) for a catalog or for the name of your nearest supplier.

**▲ WARNING** Since accessories other than those offered by Porter-Cable•Delta have not been tested with this product, use of such accessories could be hazardous. For safest operation, only Porter-Cable•Delta recommended accessories should be used with this product.

# WARRANTY

## PORTER-CABLE LIMITED ONE YEAR WARRANTY

Porter-Cable warrants its Professional Power Tools for a period of one year from the date of original purchase. We will repair or replace at our option, any part or parts of the product and accessories covered under this warranty which, after examination, proves to be defective in workmanship or material during the warranty period. For repair or replacement return the complete tool or accessory, transportation prepaid, to your nearest Porter-Cable Service Center or Authorized Service Station. Proof of purchase may be required. This warranty does not apply to repair or replacement required due to misuse, abuse, normal wear and tear or repairs attempted or made by other than our Service Centers or Authorized Service Stations.

ANY IMPLIED WARRANTY, INCLUDING THE IMPLIED WARRANTIES OF MERCHANTABILITY AND FITNESS FOR A PARTICULAR PURPOSE, WILL LAST ONLY FOR ONE (1) YEAR FROM THE DATE OF PURCHASE.

To obtain information on warranty performance please write to: PORTER-CABLE CORPORATION, 4825 Highway 45 North, Jackson, Tennessee 38305; Attention: Product Service. THE FOREGOING OBLIGATION IS PORTER-CABLE'S SOLE LIABILITY UNDER THIS OR ANY IMPLIED WARRANTY AND UNDER NO CIRCUMSTANCES SHALL PORTER-CABLE BE LIABLE FOR ANY INCIDENTAL OR CONSEQUENTIAL DAMAGES. Some states do not allow limitations on how long an implied warranty lasts or the exclusion or limitation of incidental or consequential damages, so the above limitation or exclusion may not apply to you.

This warranty gives you specific legal rights and you may also have other legal rights which vary from state to state.



# PORTER-CABLE • DELTA SERVICE CENTERS (CENTROS DE SERVICIO DE PORTER-CABLE • DELTA) (CENTRE DE SERVICE PORTER-CABLE • DELTA)

**Parts and Repair Service for Porter-Cable • Delta Power Tools are Available at These Locations  
(Obtenga Refaccion de Partes o Servicio para su Herramienta en los Siguientes Centros de Porter-Cable • Delta)  
(Locations où vous trouverez les pièces de rechange nécessaires ainsi qu'un service d'entretien)**

## ARIZONA

Tempe 85282 (Phoenix)  
2400 West Southern Avenue  
Suite 105  
Phone: (602) 437-1200  
Fax: (602) 437-2200

## CALIFORNIA

Ontario 91761 (Los Angeles)  
3949A East Guasti Road  
Phone: (909) 390-5555  
Fax: (909) 390-5554

San Diego 92111  
7638 Clairemont Blvd.  
Phone: (858) 277-9595  
Fax: (858) 277-9696

San Leandro 94577 (Oakland)  
3039 Teagarden Street  
Phone: (510) 357-9762  
Fax: (510) 357-7939

## COLORADO

Arvada 80003 (Denver)  
8175 Sheridan Blvd., Unit S  
Phone: (303) 487-1809  
Fax: (303) 487-1868

## FLORIDA

Davie 33314 (Miami)  
4343 South State Rd. 7 (441)  
Unit #107  
Phone: (954) 321-6635  
Fax: (954) 321-6638

Tampa 33609  
4538 W. Kennedy Boulevard  
Phone: (813) 877-9585  
Fax: (813) 289-7948

## GEORGIA

Forest Park 30297 (Atlanta)  
5442 Frontage Road,  
Suite 112  
Phone: (404) 608-0006  
Fax: (404) 608-1123

## ILLINOIS

Addison 60101 (Chicago)  
400 South Rohlwing Rd.  
Phone: (630) 424-8805  
Fax: (630) 424-8895

Woodridge 60517 (Chicago)  
2033 West 75th Street  
Phone: (630) 910-9200  
Fax: (630) 910-0360

## MARYLAND

Elkridge 21075 (Baltimore)  
7397-102 Washington Blvd.  
Phone: (410) 799-9394  
Fax: (410) 799-9398

## MASSACHUSETTS

Franklin 02038 (Boston)  
Franklin Industrial Park  
101E Constitution Blvd.  
Phone: (508) 520-8802  
Fax: (508) 528-8089

## MICHIGAN

Madison Heights 48071 (Detroit)  
30475 Stephenson Highway  
Phone: (248) 597-5000  
Fax: (248) 597-5004

## MINNESOTA

Minneapolis 55429  
5522 Lakeland Avenue North  
Phone: (763) 561-9080  
Fax: (763) 561-0653

## MISSOURI

North Kansas City 64116  
1141 Swift Avenue  
Phone: (816) 221-2070  
Fax: (816) 221-2897

St. Louis 63119

7574 Watson Road  
Phone: (314) 968-8950  
Fax: (314) 968-2790

## NEW YORK

Flushing 11365-1595 (N.Y.C.)  
175-25 Horace Harding Expwy.  
Phone: (718) 225-2040  
Fax: (718) 423-9619

## NORTH CAROLINA

Charlotte 28270  
9129 Monroe Road, Suite 115  
Phone: (704) 841-1176  
Fax: (704) 708-4625

## OHIO

Columbus 43214  
4560 Indianola Avenue  
Phone: (614) 263-0929  
Fax: (614) 263-1238

Cleveland 44125

8001 Sweet Valley Drive  
Unit #19  
Phone: (216) 447-9030  
Fax: (216) 447-3097

## OREGON

Portland 97230  
4916 NE 122 nd Ave.  
Phone: (503) 658-0107  
Fax: (503) 252-2123

## PENNSYLVANIA

Willow Grove 19090 (Philadelphia)  
520 North York Road  
Phone: (215) 658-1430  
Fax: (215) 658-1433

## TEXAS

Carrollton 75006 (Dallas)  
1300 Interstate 35 N, Suite 112  
Phone: (972) 446-2996  
Fax: (972) 446-8157

Houston 77043

4321 Sam Houston Parkway, West  
Suite 180  
Phone: (713) 983-9910  
Fax: (713) 983-6645

## WASHINGTON

Auburn 98001 (Seattle)  
3320 West Valley HWY, North  
Building D, Suite 111  
Phone: (253) 333-8353  
Fax: (253) 333-9613

Authorized Service Stations are located in many large cities. Telephone **800-487-8665** or **731-541-6042** for assistance locating one. Parts and accessories for Porter-Cable • Delta products should be obtained by contacting any Porter-Cable • Delta Distributor, Authorized Service Center, or Porter-Cable • Delta Factory Service Center. If you do not have access to any of these, call **888-848-5175** and you will be directed to the nearest Porter-Cable • Delta Factory Service Center. Las Estaciones de Servicio Autorizadas están ubicadas en muchas grandes ciudades. Llame al **800-487-8665** o al **731-541-6042** para obtener asistencia a fin de localizar una. Las piezas y los accesorios para los productos Porter-Cable • Delta deben obtenerse poniéndose en contacto con cualquier distribuidor Porter-Cable • Delta, Centro de Servicio Autorizado o Centro de Servicio de Fábrica Porter-Cable • Delta. Si no tiene acceso a ninguna de estas opciones, llame al **888-848-5175** y le dirigirán al Centro de Servicio de Fábrica Porter-Cable • Delta más cercano. Des centres de service agréés sont situés dans beaucoup de grandes villes. Appelez au **800-487-8665** ou au **731-541-6042** pour obtenir de l'aide pour en repérer un. Pour obtenir des pièces et accessoires pour les produits Porter-Cable • Delta, s'adresser à tout distributeur Porter-Cable • Delta, centre de service agréé ou centre de service d'usine Porter-Cable • Delta. Si vous n'avez accès à aucun de ces centres, appeler le **888-848-5175** et on vous dirigera vers le centre de service d'usine Porter-Cable • Delta. Si le plus proche.

## CANADIAN PORTER-CABLE • DELTA SERVICE CENTERS

### ALBERTA

Bay 6, 2520-23rd St. N.E.  
Calgary, Alberta  
T2E 8L2  
Phone: (403) 735-6166  
Fax: (403) 735-6144

### BRITISH COLUMBIA

8520 Baxter Place  
Burnaby, B.C.  
V5A 4T8  
Phone: (604) 420-0102  
Fax: (604) 420-3522

### MANITOBA

1699 Dublin Avenue  
Winnipeg, Manitoba  
R3H 0H2  
Phone: (204) 633-9259  
Fax: (204) 632-1976

### ONTARIO

505 Southgate Drive  
Guelph, Ontario  
N1H 6M7  
Phone: (519) 767-4132  
Fax: (519) 767-4131

### QUÉBEC

1515 Ave.  
St-Jean Baptiste, Suite 160  
Québec, P.Q.  
G2E 5E2  
Phone: (418) 877-7112  
Fax: (418) 877-7123

1447, Begin  
St-Laurent, (Mt), P.Q.  
H4R 1V8  
Phone: (514) 336-8772  
Fax: (514) 336-3505

The following are trademarks of PORTER-CABLE • DELTA (Las siguientes son marcas registradas de PORTER-CABLE • DELTA S.A.) (Les marques suivantes sont des marques de fabricant de la PORTER-CABLE • DELTA): Auto-Set®, BAMMER®, B.O.S.S.®, Builder's Saw®, Contractor's Saw®, Contractor's Saw II™, Delta™, DELTACRAFT™, DELTAGRAM™, Delta Series 2000™, DURATRONIC™, Emc2™, FLEX®, Flying Chips™, FRAME SAW®, Grip Vac™, Homcraft®, INNOVATION THAT WORKS®, Jet-Lock®, JETSTREAM®, 'kickstand', LASERLOC®, MICRO-SET®, Micro-Set®, MLDI LATHE®, MORTEM™, NETWORK™, OMNIJIG®, POCKET CUTTER®, PORTA-BAND®, PORTA-PLANE®, PORTER-CABLE®&(design), PORTER-CABLE® PROFESSIONAL POWER TOOLS, PORTER-CABLE REDEFINING PERFORMANCE™, Posi-Matic®, Q-3®&(design), QUICKSAND®&(design), QUICKSET™, QUICKSET II®, QUICKSET PLUS™, RIPTIDE™&(design), SAFE GUARD II®, SAFE-LOC®, Sanding Center®, SANDTRAP®&(design), SAW BOSS®, Sawbuck™, Sidekick®, SPEED-BLOC®, SPEEDMATIC®, SPEEDTRONIC®, STAIR EASE®, The American Woodshop®&(design), The Lumber Company®&(design), THE PROFESSIONAL EDGE®, THE PROFESSIONAL SELECT®, THIN-LINE™, TIGER®, TIGER CUB®, TIGER SAW®, TORQBUSTER®, TORQ-BUSTER®, TRU-MATCH™, TWIN-LITE®, UNIGUARD®, Unifencer®, UNIFEEDER™, Unihead®, Uniplane™, Unirip®, Unisaw®, Univise®, Versa-Feeder®, VERSA-PLANE®, WHISPER SERIES®, WOODWORKER'S CHOICE™.

Trademarks noted with ™ and ® are registered in the United States Patent and Trademark Office and may also be registered in other countries. Las Marcas Registradas con el signo de ™ y ® son registradas por la Oficina de Registros y Patentes de los Estados Unidos y también pueden estar registradas en otros países. Marques déposées, indiquées par la lettre ™ et ®, sont déposées au Bureau des brevets d'invention et marques déposées aux Etats-Unis et pourraient être déposées aux autres pays.