

PORTER CABLE®

10 IN. (254 MM) STATIONARY TABLE SAW
BANC DE SCIE 254 MM (10 PO)
SIERRA DE MESA 254 MM (10 PULG.)

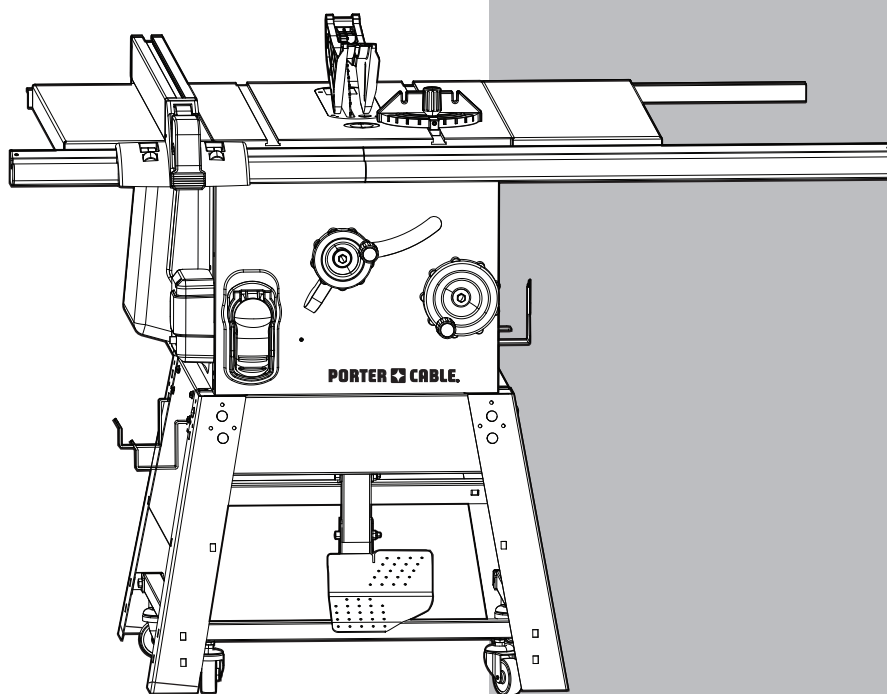

Instruction Manual
Manuel d'instructions
Manual de instrucciones

www.portercable.com

INSTRUCTIVO DE OPERACIÓN, CENTROS
DE SERVICIO Y PÓLIZA DE GARANTÍA.

 **ADVERTENCIA:** LÉASE ESTE
INSTRUCTIVO ANTES DE USAR EL
PRODUCTO.

CATALOG NUMBER
PCB270TS

TABLE OF CONTENTS

SECTION	PAGE
PRODUCT SPECIFICATIONS	2
CALIFORNIA PROPOSITION 65	2
SAFETY GUIDELINES - DEFINITIONS	3
POWER TOOL SAFETY	4
TABLE SAW SAFETY	5
ELECTRICAL REQUIREMENTS AND SAFETY	7
TOOLS NEEDED FOR ASSEMBLY	8
CARTON CONTENTS	9
KNOW YOUR TABLE SAW.....	11
GLOSSARY OF TERMS.....	12
ASSEMBLY AND ADJUSTMENTS.....	13
OPERATION	23
MAINTENANCE	29
TROUBLESHOOTING GUIDE.....	30
ACCESSORIES AND ATTACHMENTS	31
PARTS LIST	33
WARRANTY	38

PRODUCT SPECIFICATIONS

MOTOR

Type	Induction
Amps.....	15 / 7.5
Voltage	120 / 240
Hz.....	60
RPM (no load).....	3450
Overload Protection.....	YES

MITER GAUGE

YES

RIP FENCE

YES

SAW

Table Size.....	27-1/8 in. x 20-1/8 in. (688 mm x 512 mm)
Table Extensions.....	Right & Left
Extension Fence Capacity.....	30 in. (762 mm) Right
Blade Size.....	10 in. (254 mm)
Blade Arbor.....	5/8 in. (15.9 mm)

CUTTING CAPACITY

Maximum Cut Depth @ 90°.....	3-1/2in.(88.9 mm)
Maximum Cut Depth @ 45°.....	2-1/4 in.(57.1 mm)
Maximum Dado Cut Width.....	13/16 in.(20.6 mm)
Maximum Dado Blade Diameter..	8 in. (203.2mm)

WARNING

To avoid electrical hazards, fire hazards or damage to the tool, use proper circuit protection. Use a separate electrical circuit for your tools. To avoid electrical hazards, fire hazards or damage to the table saw, use proper circuit protection. This table saw is wired at the factory for 110-120/220-240 Volt operation. It must be connected to a 110-120 Volt / 15 Ampere or 220-240 Volt / 7.5 Ampere time delay fuse or circuit breaker. To avoid shock or fire, replace power cord immediately if it is worn, cut or damaged in any way.

CALIFORNIA PROPOSITION 65

WARNING

Some dust created by power sanding, sawing, grinding, drilling and other construction activities contains chemicals known to the state of California to cause cancer, birth defects or other reproductive harm. Some examples of these chemicals are:

- Lead from lead-based paints,
- Crystalline silica from bricks and cement and other masonry products, and
- Arsenic and chromium from chemically-treated lumber.

Your risk from these exposures varies, depending on how often you do this type of work. To reduce your exposure to these chemicals: work in a well ventilated area, and work with approved safety equipment, such as those dust masks that are specially designed to filter out microscopic particles.

Avoid prolonged contact with dust from power sanding, sawing, grinding, drilling, and other construction activities. Wear protective clothing and wash exposed areas with soap and water. Allowing dust to get into your mouth, eyes, or lay on the skin may promote absorption of harmful chemicals.

WARNING

Use of this tool can generate and/or disperse dust, which may cause serious and permanent respiratory or other injury. Always use NIOSH/OSHA approved respiratory protection appropriate for the dust exposure. Direct particles away from face and body.

SAFETY GUIDELINES - DEFINITIONS

WARNING ICONS

Your power tool and its Instruction Manual may contain “WARNING ICONS” (a picture symbol intended to alert you to, and/or instruct you how to avoid, a potentially hazardous condition). Understanding and heeding these symbols will help you operate your tool better and safer. Shown below are some of the symbols you may see.



SAFETY ALERT: Precautions that involve your safety.



PROHIBITION



WEAR EYE PROTECTION: Always wear safety goggles or safety glasses with side shields.



WEAR RESPIRATORY AND HEARING PROTECTION: Always wear respiratory and hearing protection.



READ AND UNDERSTAND INSTRUCTION MANUAL: To reduce the risk of injury, user and all bystanders must read and understand instruction manual before using this product.



KEEP HANDS AWAY FROM BLADE: Failure to keep your hands away from the blade will result in serious personal injury.



SUPPORT AND CLAMP WORK



DANGER

DANGER: Indicates an imminently hazardous situation which, if not avoided, will result in death or serious injury.



WARNING

WARNING: Indicates a potentially hazardous situation which, if not avoided, could result in death or serious injury.



CAUTION

CAUTION: Indicates a potentially hazardous situation which, if not avoided, may result in minor or moderate injury.

CAUTION

CAUTION: Used without the safety alert symbol indicates a potentially hazardous situation which, if not avoided, may result in property damage.



POWER TOOL SAFETY

GENERAL SAFETY INSTRUCTIONS BEFORE USING THIS POWER TOOL

Safety is a combination of common sense, staying alert and knowing how to use your power tool.

WARNING

- **To avoid mistakes that could cause serious injury, do not plug the tool in until you have read and understood the following.**
- **Read all instructions before operating product. Failure to follow all instructions listed below may result in electric shock, fire and/or serious injury.**

1.  **READ** and become familiar with the entire Instruction Manual. **LEARN** the tool's application, limitations and possible hazards.
2. **KEEP GUARDS IN PLACE** and in working order.
3. **REMOVE ADJUSTING KEYS AND WRENCHES.** Form the habit of checking to see that keys and adjusting wrenches are removed from the tool before turning ON.
4. **KEEP WORK AREA CLEAN.** Cluttered areas and benches invite accidents.
5. **DO NOT USE IN DANGEROUS ENVIRONMENTS.** Do not use power tools in damp locations, or expose them to rain or snow. Keep work area well lit.
6. **KEEP CHILDREN AWAY.** All visitors and bystanders should be kept a safe distance from work area.
7. **MAKE WORKSHOP CHILD PROOF** with padlocks, master switches or by removing starter keys.
8. **DO NOT FORCE THE TOOL.** It will do the job better and safer at the rate for which it was designed.
9. **USE THE RIGHT TOOL.** Do not force the tool or an attachment to do a job for which it was not designed.
10. **USE PROPER EXTENSION CORDS.** Make sure your extension cord is in good condition. When using an extension cord, be sure to use one heavy enough to carry the current your product will draw. An undersized cord will result in a drop in line voltage and in loss of power which will cause the tool to overheat. The table on page 7 shows the correct size to use depending on cord length and nameplate ampere rating. If in doubt, use the next heavier gauge. The smaller the gauge number, the heavier the cord.
11. **WEAR PROPER APPAREL.** Do not wear loose clothing, gloves, neckties, rings, bracelets or other jewelry which may get caught in moving parts. Nonslip footwear is recommended. Wear protective hair covering to contain long hair.
12.  **ALWAYS WEAR EYE PROTECTION.** Any power tool can throw foreign objects into the eyes and could cause permanent eye damage. **ALWAYS** wear Safety Goggles (not glasses) that comply with ANSI Safety standard

Z87.1. Everyday eyeglasses have only impact-resistant lenses. They **ARE NOT** safety glasses. **NOTE:** Glasses or goggles not in compliance with ANSI Z87.1 could seriously injure you when they break.



13.  **WEAR A FACE MASK OR DUST MASK.** Sawing operation produces dust.
14.  **SECURE WORK.** Use clamps or a vise to hold work when practical. It is safer than using your hand and it frees both hands to operate the tool.
15. **DISCONNECT TOOLS FROM POWER SOURCE** before servicing, and when changing accessories such as blades, bits and cutters.
16. **REDUCE THE RISK OF UNINTENTIONAL STARTING.** Make sure switch is in the OFF position before plugging the tool in.
17. **USE RECOMMENDED ACCESSORIES.** Consult this Instruction Manual for recommended accessories. The use of improper accessories may cause risk of injury to yourself or others.
18. **NEVER STAND ON THE TOOL.** Serious injury could occur if the tool is tipped or if the cutting tool is unintentionally contacted.
19. **CHECK FOR DAMAGED PARTS.** Before further use of the tool, a guard or other part that is damaged should be carefully checked to determine that it will operate properly and perform its intended function – check for alignment of moving parts, binding of moving parts, breakage of parts, mounting and any other conditions that may affect its operation. A guard or other part that is damaged should be properly repaired or replaced.
20. **NEVER LEAVE THE TOOL RUNNING UNATTENDED. TURN THE POWER “OFF”.** Do not walk away from a running tool until the blade comes to a complete stop and the tool is unplugged from the power source.
21. **DO NOT OVERREACH.** Keep proper footing and balance at all times.
22. **MAINTAIN TOOLS WITH CARE.** Keep tools sharp and clean for best and safest performance. Follow instructions for lubricating and changing accessories.
23. **DO NOT** use power tool in presence of flammable liquids or gases.
24. **DO NOT** operate the tool if you are under the influence of any drugs, alcohol or medication that could affect your ability to use the tool properly.
25. Dust generated from certain materials can be hazardous to your health. Always operate saw in well-ventilated area and provide for proper dust removal.
26.  **WEAR HEARING PROTECTION** to reduce the risk of induced hearing loss.

TABLE SAW SAFETY

1. **ALWAYS USE SAW BLADE GUARD**, riving knife and anti-kickback pawls for every through-sawing operation. Through-sawing operations are those in which the blade cuts completely through the workpiece when ripping or crosscutting. Always be sure blade guard is tightened securely.
 2. **ALWAYS HOLD WORK FIRMLY** against the miter gauge or rip fence.
 3. **ALWAYS USE** a push stick, especially when ripping narrow stock. Refer to ripping instructions in this Instruction Manual where the push stick is covered in detail. A pattern for making your own push stick is included on page 32.
 4. **NEVER PERFORM ANY OPERATION FREEHAND, which means using only your hands to support or guide the workpiece. Always use either the fence or the miter gauge to position and guide the work.**
- ⚠ WARNING**
- FREEHAND CUTTING IS THE MAJOR CAUSE OF KICKBACK AND FINGER/HAND AMPUTATIONS.**
5. **NEVER STAND** or have any part of your body in line with the path of the saw blade. Keep your hands out of the saw blade path.
 6. **NEVER REACH** behind or over the cutting tool for any reason.
 7. **REMOVE** the rip fence when crosscutting.
 8. **DO NOT USE** a molding head with this saw.
 9. **FEED WORK INTO THE BLADE** against the direction of rotation only.
 10. **NEVER** use the rip fence as a cut-off gauge when crosscutting.
 11. **NEVER ATTEMPT TO FREE A STALLED SAW BLADE** without first turning the saw OFF. Turn power switch OFF immediately to prevent motor damage.
 12. **PROVIDE ADEQUATE SUPPORT** to the rear and the sides of the saw table for long or wide workpieces.
 13. **AVOID KICKBACKS** (work thrown back towards you) by keeping the blade sharp, the rip fence parallel to the saw blade and by keeping the riving knife, anti-kickback pawls and guards in place, aligned and functioning. Do not release work before passing it completely beyond the saw blade. Do not rip work that is twisted, warped or does not have a straight edge to guide it along the fence.
 14. **AVOID AWKWARD OPERATIONS** and hand positions where a sudden slip could cause your hand to move into the saw blade.
 15. **NEVER USE SOLVENTS** to clean plastic parts. Solvents could possibly dissolve or otherwise damage the material. Only a soft damp cloth should be used to clean plastic parts.
 16. **MOUNT** your table saw on a bench or stand before performing any cutting operations. Refer to **ASSEMBLY AND ADJUSTMENTS** on page 13. Secure tool properly to prevent unexpected movement.
 17. **NEVER CUT METALS** or materials that may make hazardous dust.
 18. **ALWAYS USE IN A WELL-VENTILATED AREA.** Remove sawdust frequently. Clean out sawdust from the interior of the saw to prevent a potential fire hazard. Attach a vacuum to the dust port for additional sawdust removal.
 19. **NEVER LEAVE THE SAW RUNNING UNATTENDED.** Do not leave the saw until the blade comes to a complete stop.
 20. For proper operation follow the instructions in this Instruction Manual entitled **ASSEMBLY AND ADJUSTMENTS** (Page 13). Failure to provide sawdust fall-through and removal hole will allow sawdust to build up in the motor area resulting in a fire hazard and potential motor damage.
 21. **USE ONLY** saw blades recommended with warning that the riving knife shall not be thicker than the width of the groove cut by the saw blade and not thinner than the body of the saw blade.
 22. **USE PUSH-STICK OR PUSH BLOCK** to feed the workpiece past the saw blade. The push-stick or push block should always be stored with the machine when not in use.
 23. **DIRECTION OF FEED.** Feed work into a blade against the direction of rotation of the blade.

TABLE SAW SAFETY

SAW BLADE GUARD ASSEMBLY, ANTI-KICKBACK ASSEMBLY AND RIVING KNIFE

Your table saw is equipped with a blade guard assembly, anti-kickback assembly and riving knife that covers the blade and reduces the possibility of accidental blade contact. The riving knife is a flat plate that fits into the cut made by the saw blade and effectively fights kickback by lessening the tendency of the blade to bind in the cut. The blade guard assembly and anti-kickback assembly can only be used when making through cuts that sever the wood. When making rabbets and other cuts that make non through cuts, the blade guard assembly and anti-kickback assembly must be removed and riving knife lowered to the non through cut position marked on the riving knife. Two anti-kickback pawls are located on the sides of the riving knife that allow the wood to pass through the blade in the cutting direction but reduce the possibility of the material being thrown backwards toward the operator. Use all components of the guarding system (blade guard assembly, riving knife and anti-kickback assembly) for every operation for which they can be used including all through cutting. If you elect not to use any of these components for a particular application exercise additional caution regarding control of the workpiece, the use of push sticks, the position of your hands relative to the blade, the use of safety glasses, the means to avoid kickback and all other warnings contained in this manual and on the saw itself. Replace the guarding systems as soon as you return to thru-cutting operations. Keep the guard assembly in working order.

KICKBACKS

KICKBACKS: Kickbacks can cause serious injury. A kickback occurs when a part of the workpiece binds between the saw blade and the rip fence, or other fixed object, and rises from the table and is thrown toward the operator. Kickbacks can be avoided by attention to the following conditions.

How to Avoid Them and Protect Yourself from Possible Injury:

- a. Be certain that the rip fence is parallel to the saw blade.
- b. Do not rip by applying the feed force to the section of the workpiece that will become the cut-off (free) piece. Feed force when ripping should always be applied between the saw blade and the fence; use a push stick for narrow work, 6 in. (152 mm) wide or less.
- c. Keep saw blade guard assembly, riving knife and anti-kickback assembly in place and operating properly. If anti-kickback assembly is not operational, return your unit to the nearest authorized service center for repair. The riving knife must be in alignment with the saw blade and the anti-kickback assembly must stop a kickback once it has started. Check their action before ripping by pushing the wood under the antikickback assembly. The teeth must prevent the wood from being pulled toward the front of the saw.
- d. Plastic and composite (like hardboard) materials may be cut on your saw. However, since these are usually quite hard and slippery, the anti-kickback pawls may not stop a kickback. Therefore, be especially attentive to following proper set up and cutting procedures for ripping.
- e. Use saw blade guard assembly, anti-kickback assembly and riving knife for every operation for which it can be used, including all through-sawing.
- f. Push the workpiece past the saw blade prior to release.
- g. Never rip a workpiece that is twisted or warped, or does not have a straight edge to guide along the fence.
- h. Never saw a large workpiece that cannot be controlled.
- i. Never use the fence as a guide or length stop when crosscutting.
- j. Never saw a workpiece with loose knots, flaws, nails or other foreign objects.
- k. Never rip a workpiece shorter than 10 in. (254 mm).
- l. NEVER use a dull blade – replace or have resharpened.
- m. NEVER use a rip fence and miter gauge together.
- n. Keep hands out of saw blade.

ELECTRICAL REQUIREMENTS AND SAFETY

POWER SUPPLY AND MOTOR SPECIFICATIONS

⚠ WARNING

To avoid electrical hazards, fire hazards, or damage to the tool, use proper circuit protection. Use a separate electrical circuit for your tool. Your saw is wired at the factory for 120 V operation. Connect to a 120 V, 15 Amp circuit and use a 15 Amp time delay fuse or circuit breaker. To avoid shock or fire, if power cord is worn, cut, or damaged in any way, have it replaced immediately.

GROUNDING INSTRUCTIONS

⚠ WARNING

This tool must be grounded while in use to protect the operator from electrical shock.

IN THE EVENT OF A MALFUNCTION OR BREAKDOWN, grounding provides a path of least resistance for electric currents and reduces the risk of electric shock. This tool is equipped with an electrical cord that has an equipment-grounding conductor and a grounding plug. The plug must be plugged into a matching receptacle that is properly installed and grounded in accordance with all local codes and ordinances.

DO NOT MODIFY THE PLUG PROVIDED. If it will not fit the receptacle, have the proper receptacle installed by a qualified electrician.

IMPROPER CONNECTION of the equipment grounding conductor can result in risk of electric shock. The conductor with the green insulation (with or without yellow stripes) is the equipment grounding conductor. If repair or replacement of the electrical cord or plug is necessary, do not connect the equipment grounding conductor to a live terminal.

CHECK with a qualified electrician or service person if you do not completely understand the grounding instructions, or if you are not certain the tool is properly grounded.

USE only 3-wire extension cords that have three-pronged grounding plugs with three-pole receptacles that accept the tool's plug. Repair or replace damaged or worn cords immediately.

Use a separate electrical circuit for your tool. This circuit must not be less than #14 wire and should be protected with a 15 Amp time lag fuse. Before connecting the motor to the power line, make sure the switch is in the off position and the electric current is rated the same as the current stamped on the motor nameplate. Running at a lower voltage will damage the motor.

GUIDELINES FOR EXTENSION CORDS

USE THE PROPER EXTENSION CORD. Make sure your extension cord is in good condition. Use an extension cord heavy enough to carry the current your product will draw. An undersized cord will cause a drop in line voltage resulting in loss of power, overheating

and burning out of the motor. The table below shows the correct size to use depending on cord length and nameplate ampere rating. If in doubt, use the next heavier gauge. The smaller the gauge number, the heavier the cord.

Make sure your extension cord is properly wired and in good condition. Always replace a damaged extension cord or have it repaired by a qualified technician before using it. Protect your extension cords from sharp objects, excessive heat and damp or wet areas.

MINIMUM GAUGE FOR EXTENSION CORDS (AWG)						
Ampere Rating		Total length of Cord				
More Than	Not More Than	120V	25	50	100	150
			(7.62	15.24	30.48	45.72
		240V	50	100	200	300
			(15.24	30.48	60.96	91.44
AWG - American Wire Gauge						
0	6	18	16	16	14	
6	10	18	16	14	12	
10	12	16	16	14	12	
12	16	14	12	Not Recommended		

⚠ WARNING

This tool is for indoor use only. Do not expose to rain or use in damp locations.

This tool is intended for use on a circuit that has a receptacle like the one illustrated in Fig. 1. Fig. 1 shows a three-pronged electrical plug and receptacle that has a grounding conductor. If a properly grounded receptacle is not available, an adapter (Fig. 2) can be used to temporarily connect this plug to a two-contact grounded receptacle. The adapter (Fig. 2) has a rigid lug extending from it that MUST be connected to a permanent earth ground, such as a properly grounded receptacle box.

⚠ CAUTION

In all cases, make certain the receptacle is properly grounded. If you are not sure, have a qualified electrician check the receptacle.

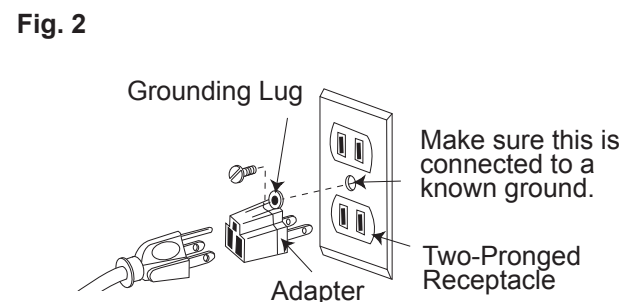
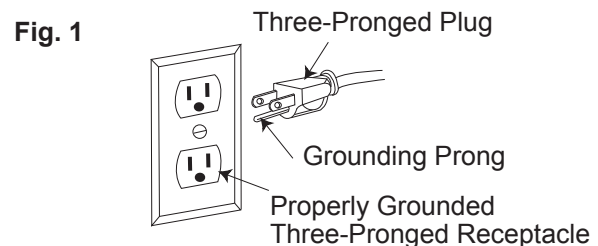

240 VOLT SINGLE PHASE OPERATION

⚠ WARNING

To avoid injury, disconnect the motor from power source outlet before reconnecting the wire.

The motor supplied with your machine is a dual voltage, 120/240 volt motor. It is shipped ready-to-run for 120 volt operation. However, it can be converted for 240 volt operation, reconnect the motor wire as the wiring diagram on page 28.

A qualified electrician should do the conversion, or the machine can be taken to an Authorized Service Center. When completed, the machine must conform to the National Electric Code and all local codes and ordinances.

The machine is converted by re-wiring the motor for 240 volts, installing a 240 volt plug on the power supply cord and replacing the switch with one that is rated for 240 volt operation.

Be sure the 240 volt plug is only used in an outlet having the same configuration as the plug illustrated in Fig. 1. No adapter should be used with the 240 volt plug.

⚠ CAUTION

In all cases, make certain that the receptacle in question is properly grounded. If you are not sure, have a qualified electrician check the receptacle.

TOOLS NEEDED FOR ASSEMBLY

Supplied



Blade wrench



6 mm hex key

Not Supplied

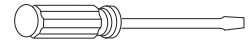

Medium screwdriver

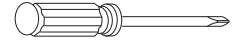

Phillips screwdriver



Straight edge



Adjustable wrench

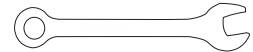

10, 13, 17 mm hex wrench

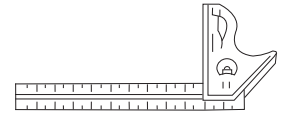

Combination square

CARTON CONTENTS

UNPACKING AND CHECKING CONTENTS

Carefully unpack the table saw and all its parts, and compare against the list below and the illustration on the next page. With the help of an assistant place the saw on a secure surface and examine it carefully.

WARNING

- To avoid injury from unexpected starting or electrical shock, do not plug the power cord into a source of power during unpacking and assembly. The cord must remain unplugged whenever you are adjusting/ assembling the saw.
- The saw is heavy and should be lifted with care. Get the assistance of someone to lift and move the saw.
- If any part is missing or damaged, do not attempt to assemble the table saw, or plug in the power cord until the missing or damaged part is correctly replaced.

TABLE OF LOOSE PARTS STAND

ITEM DESCRIPTION	QUANTITY
A. Leg set	1 set
Front right leg - no. 2	1
Rear right leg - no. 3	1
Front left leg - no. 5	1
Rear left leg - no. 6	1
B. Right leg support - no. 1	1
Left leg support - no. 4	1
C. Leg assembly hardware bag	1 set
Square neck bolts	22
Hex nuts	22
D. Front leg support - no. 7	1
E. Rear top leg support - no. 8	1
Rear bottom leg support - no. 9	1
F. Foot pads	1 set
G. Caster assembly bracket	1
H. Front casters / rear casters	2 each
I. Caster assembly hardware bag	1 set
Socket hex bolt - long	1
Socket hex bolt	2
Socket hex bolt - short	2
Hex nuts	3
6 mm hex key	1

ITEM DESCRIPTION	QUANTITY
J. Storage parts	
Miter guage storage	1
Rip fence storage	1 set
Power cord storage	1 set
Blade guard assembly storage	1 set
K. Storage parts hardware	1 set
Screws - long	2
Screws - short	2
Nuts	4
Screws with washers	6

TABLE OF LOOSE PARTS TABLE SAW

ITEM DESCRIPTION	QUANTITY
L. Table saw assembly	1
M. Right / left table extension	1 each
N. Front table extension rail	1 set
O. Rear table extension rail	1 set
P. Hex bolts	4
Q. Table extension hardware bag	1 set
R. Front rail covers	1 set
S. Front rail hardware bag	1 set
Hex bolts - long	4
Hex bolts - short	2
Square nuts	6
T. Rear rail hardware bag	1 set
Hex bolts	6
Hex nuts	2
U. Handwheel, dome nut, handle, nut	1 each
V. Riving knife	1 set
W. Anti-kickback pawl	1
X. Blade guard	1
Y. Miter gauge	1
Z. Rip fence	1 each
AA. Blade wrench	1
BB. Push stick	1

UNPACKING YOUR TABLE SAW

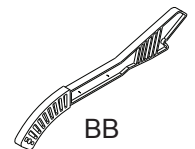
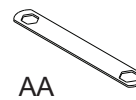
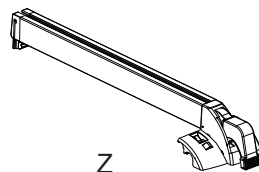
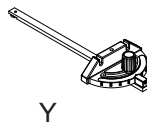
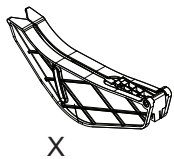
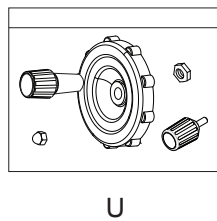
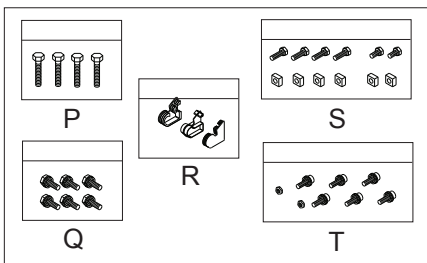
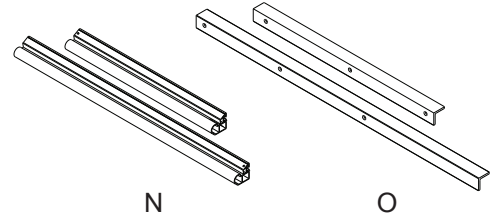
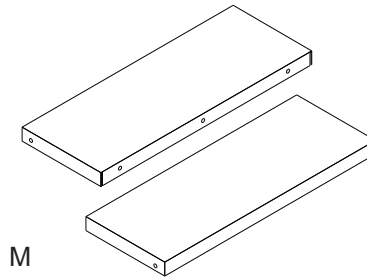
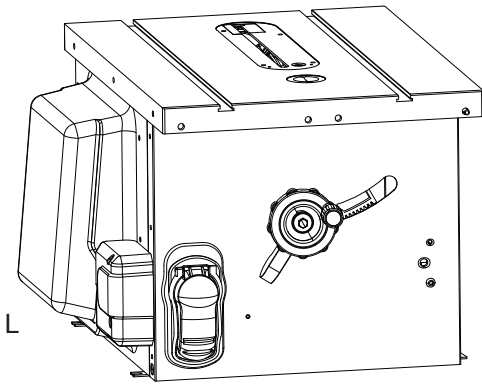
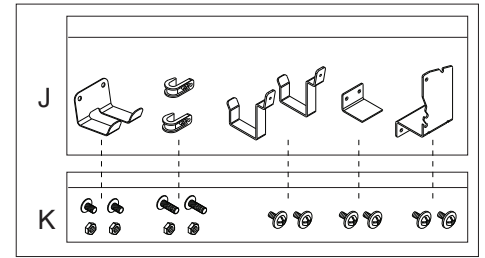
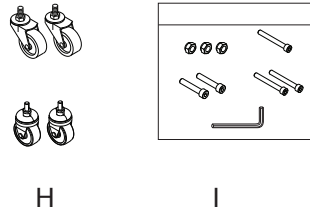
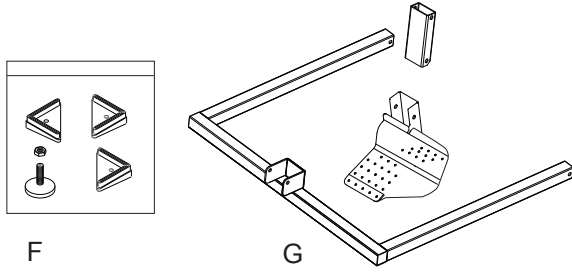
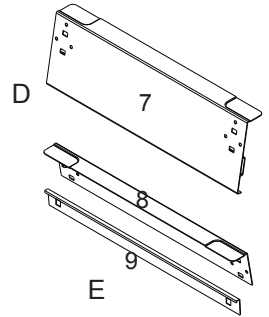
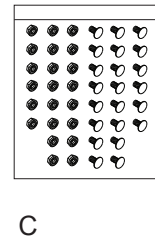
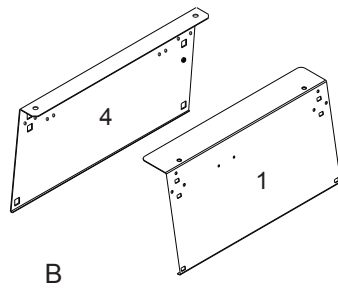
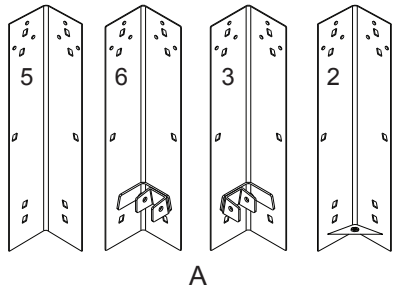

KNOW YOUR TABLE SAW

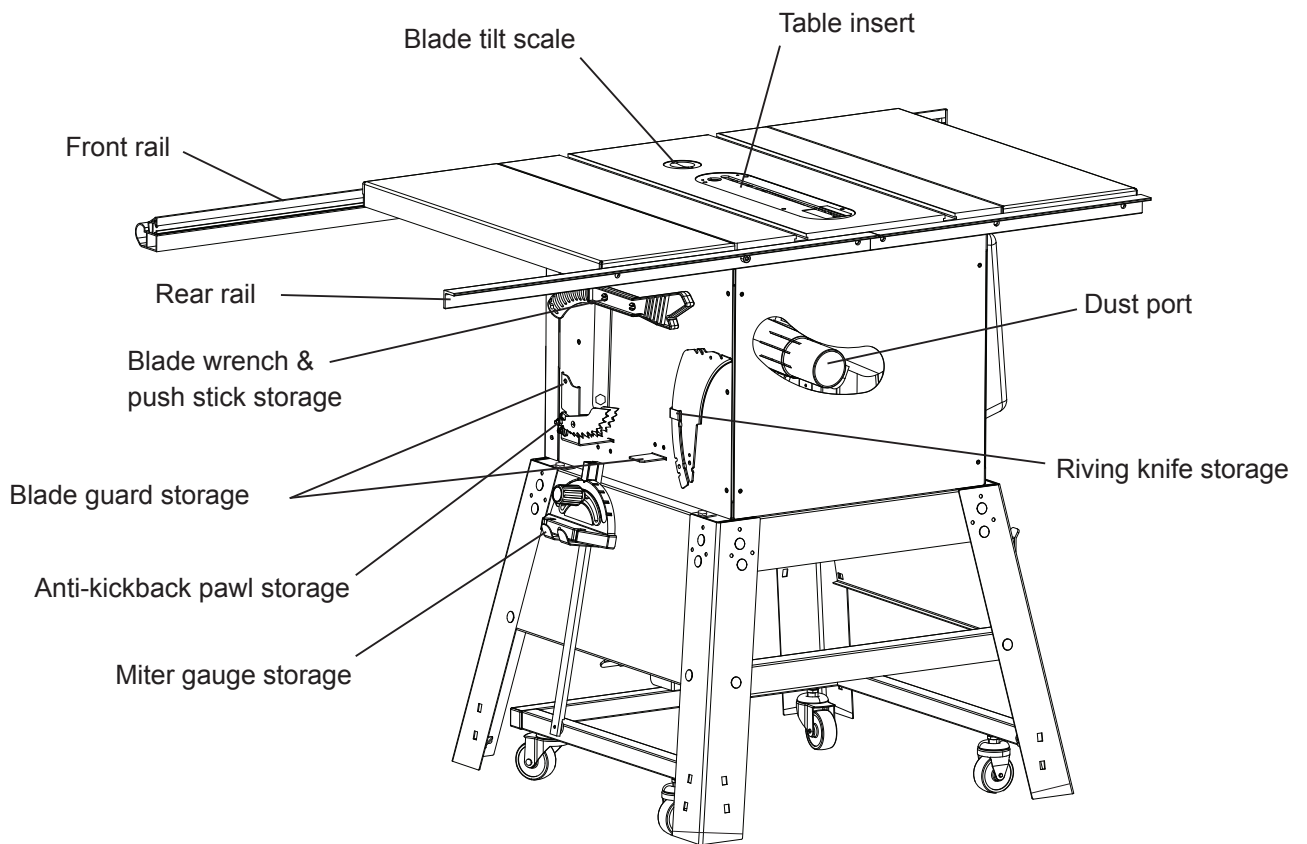
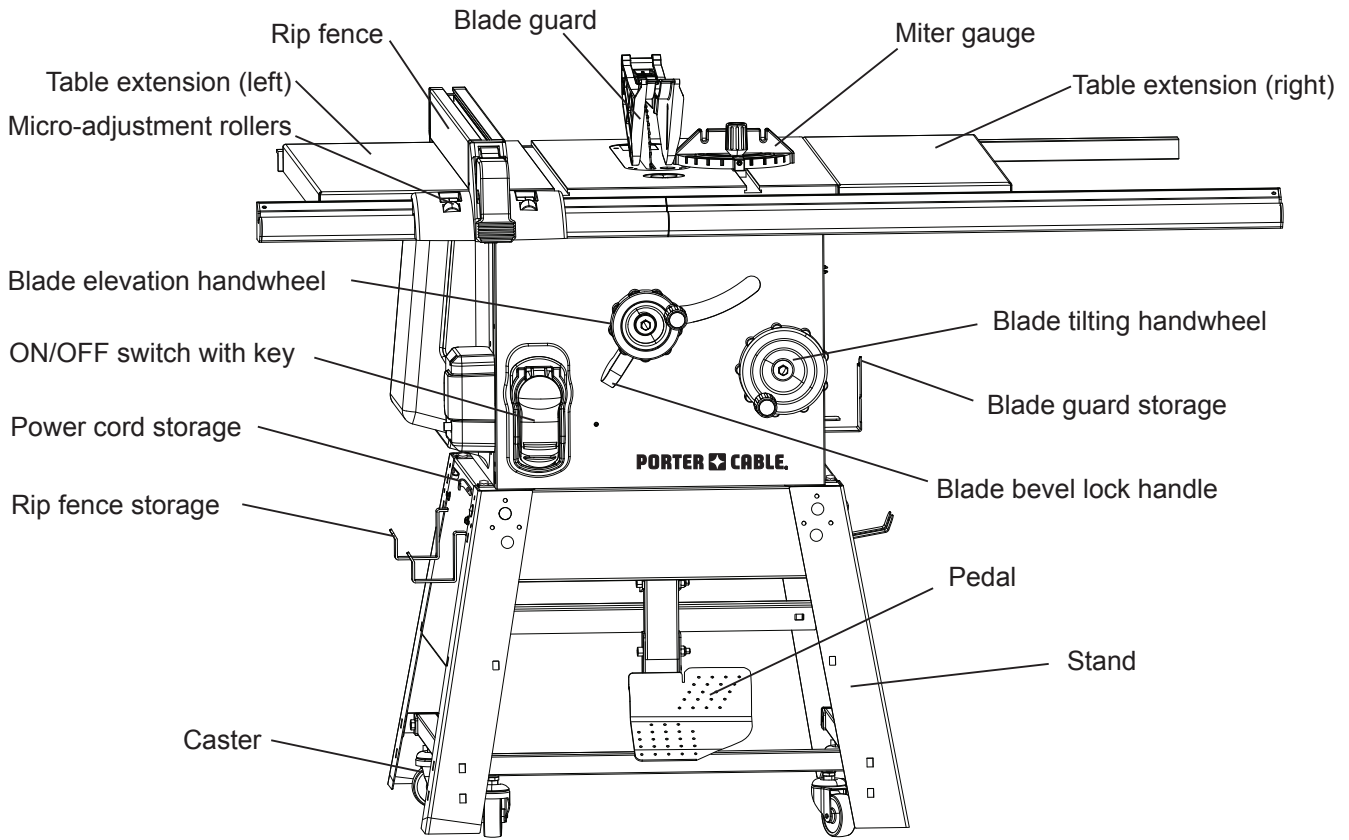

GLOSSARY OF TERMS

ANTI-KICKBACK PAWLS – Prevents the workpiece from being kicked upward or back toward the front of the table saw by the spinning blade.

ARBOR – The shaft on which the blade or dado is mounted.

BEVEL CUT – An angle cut made through the face of the workpiece.

BLADE BEVEL SCALE – Measures the angle the blade is tilted when set for a bevel cut.

BLADE ELEVATION AND TILTING HANDWHEEL – Raises and lowers the blade or tilts the blade to angle between 0° and 45° for bevel cuts.

BLADE GUARD – Clear plastic cover that positions itself over the blade while cutting.

COMPOUND CUT – A simultaneous bevel and miter cut.

CROSSCUT – A cut made across the width of the workpiece.

DADO – Special cutting blades that are used to cut grooves in a workpiece.

FEATHERBOARD – When ripping a workpiece on your table saw, this keeps it firmly and safely against the rip fence. It also helps prevent chatter, gouging, and dangerous kickback.

FREEHAND – Performing a cut without using a rip fence, miter gauge, hold down or other proper device to prevent the workpiece from twisting during the cutting operation.

GUM – A sticky sap from wood products.

HEEL – Misalignment of the blade.

JAMB NUT – Nut used to lock another nut in place on a threaded rod or bolt.

KERF – The amount of material removed by the blade cut.

KICKBACK – Occurs when the saw blade binds in the cut and violently thrusts the workpiece back toward the operator.

MITER CUT – An angle cut made across the width of the workpiece.

MITER GAUGE – A guide used for crosscutting operations that slides in the table top channels (grooves) located on either side of the blade. It helps make accurate straight or angle crosscuts.

NON-THROUGH SAWING - refers to any cut that does not completely cut through the workpiece.

OVERLOAD RESET SWITCH – Protects the motor if it overloads during operation, provides a way to restart the saw.

PUSH STICK – Used to push workpieces when performing ripping operations.

PUSH BLOCK – Used for ripping operation when the workpiece is too narrow to use a push stick. Always use a push block for rip widths less than 2 in (50.8 mm).

RESAWING - flipping material to make a cut the saw is not capable of making in one pass.

⚠ WARNING Resawing IS NOT recommended.

REVOLUTIONS PER MINUTE (RPM) – The number of turns completed by a spinning object in one minute.

RIP FENCE – A guide used for rip cutting which allows the workpiece to cut straight.

RIPPING – Cutting with the grain of the wood or along the length of the workpiece.

RIVING KNIFE – A metal piece of the guard assembly located behind and moves with the blade. Slightly thinner than the saw blade, it helps keep the kerf open and prevents kickback.

SAW BLADE PATH – The area of the workpiece or table top directly in line with the travel of the blade or the part of the workpiece that will be cut.

SET – The distance between two saw blade tips, bent outward in opposite directions to each other. The further apart the tips are, the greater the set.

TABLE INSERT – Insert that is removed from the table to install / remove blades. When dado cutting, a dado insert plate must be used.

THROUGH SAWING – Making a cut completely through the length or width of a workpiece.

WORKPIECE – Material to be cut.

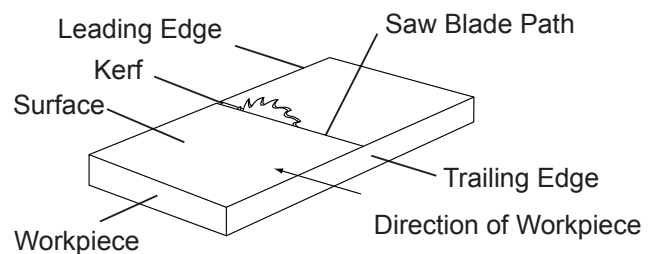

NOTE: Blade guard assembly is removed for purposes of illustration only.

ASSEMBLY AND ADJUSTMENTS

Estimated Assembly Time: 90~120 minutes
(2 people)

⚠ WARNING

For your safety, never connect plug to power source receptacle until all assembly and adjustment steps are complete, and you have read and understood the safety instructions.

ASSEMBLING STAND (FIG. A~I)

1. Unpack all parts and group by type and size. Refer to parts list for quantities. The number is labeled on each leg and leg support, please identify before assembling.

2. **Bag "C"** - Attach the right leg support (1) to the front right leg (2) and rear right leg (3) with six square neck bolts (10) and six nuts (11) to complete right frame leg.

NOTE:

- Do not tighten bolts until stand is properly aligned.
- Position all supports to the **INSIDE** of the leg assemblies.
- Align detents (12) in stand leg with supports to ensure proper fit.

3. Repeat above steps for the left frame leg - left leg support (4), front left leg (5) and rear left leg (6).

Fig. A

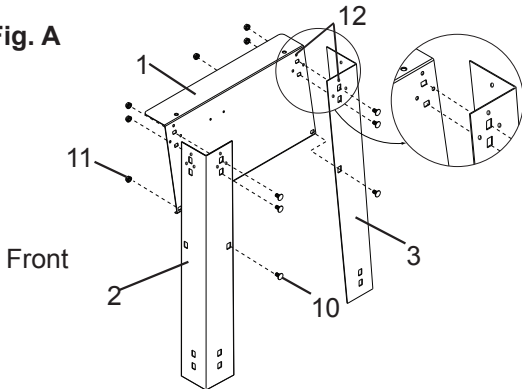

4. **Bag "C"** - Join the right frame leg and the left frame leg by using the front leg support (7), four square neck bolts (10) and four nuts (11).

Fig. B

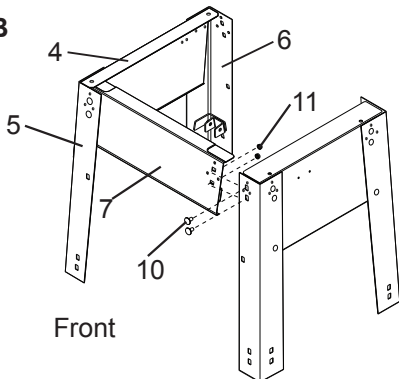

5. **Bag "C"** - Join the right frame leg and the left frame leg by using the rear top / bottom leg support (8, 9), six square neck bolts (10) and six nuts (11).

Fig. C

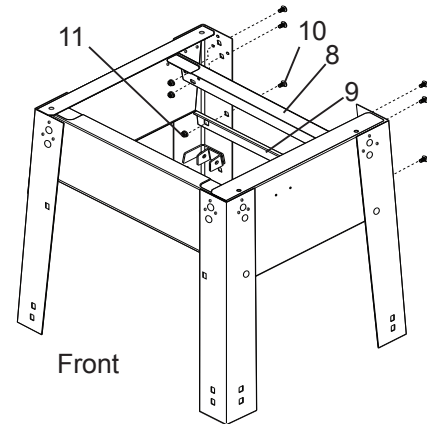

6. **Bag "F"** - Place three foot pads (13) onto the legs (3, 5, 6), thread the adjustable foot pad with hex nut (14) into the front right leg (2).

7. Place stand on level surface and adjust, so all legs are contacting the floor and are at similar angles to the floor and detents in stand leg align with supports, then tighten all bolts.

NOTE: Stand should not rock after all bolts are tightened.

Fig. D

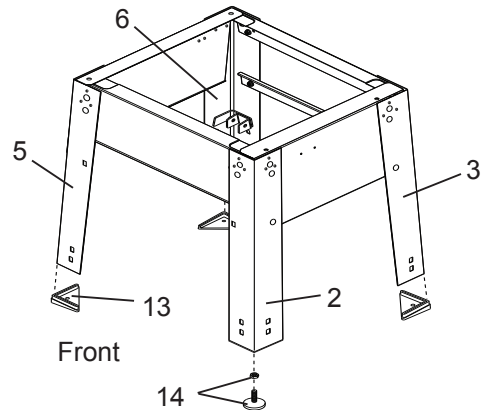

8. **Bag "H"** - Install the front casters (15) and rear casters (16) to the bottom of the caster bracket (17).
NOTE: Identify the front casters and rear casters before installing.

Fig. E

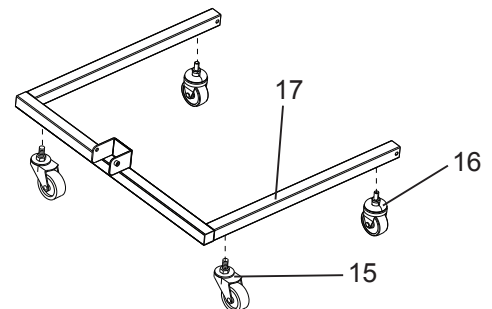

9. **Bag “I”** - Mount the pedal (1) to the caster bracket (2) by using the longest bolt (3) and nut (4), and attach the link (5) to pedal (1) with bolt (6) and nut (4) by 6 mm hex key supplied.

Fig. F

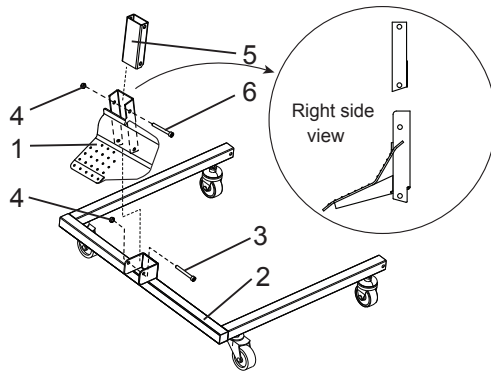

10. **Bag “I”** - Attach the left / right rear tubes (8) of caster bracket into the brackets (9) of the rear legs by using two short bolts (10). Attach the link (5) into the bracket (11) with bolt (6) and nut (4).

NOTE: Do not over tighten bolts. The caster assembly will be difficult to operate if the bolts are too tight.

Fig. G

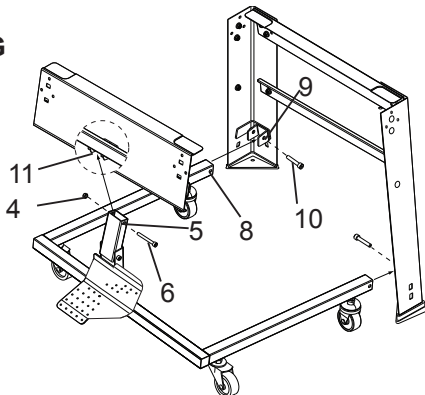

NOTE: The front right / left legs have been removed from this drawing for illustration purposes only.

11. **Bag “J, K”** - Attach miter gauge storage (12) to the right leg support by using two short screws (14) and nuts (15).

Fig. H

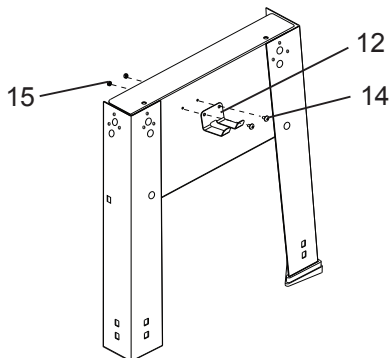

12. **Bag “J, K”** - Attach power cord storage (16) to the left leg support by using two long screws (18) and nuts (15).

13. Insert the rip fence storage (20) into slots (21) of the left leg support, tighten by using two of six screws (22).

Fig. I

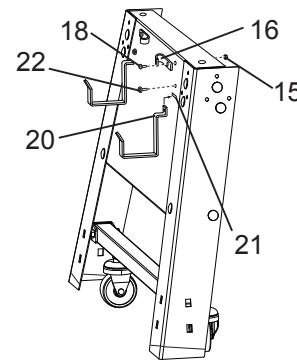

NOTE: Make sure all screws and nuts are tight and stand is on a stable surface before mounting saw.

⚠ WARNING

Although compact, this saw is heavy and should be lifted with care. Get the assistance of someone to lift and move the saw.

⚠ WARNING

For your safety, never connect plug to power source receptacle until all assembly and adjustment steps are complete, and you have read and understood the safety instructions.

ASSEMBLING TABLE SAW TO STAND (FIG. J)

1. Lift the saw body (1) and place on the stand (2), aligning the mounting grooves (3) of the saw base with the four mounting holes on the top plate of stand.
2. **Bag “P”** - Attach the table saw to the stand with four hex head bolts (4).
3. Tighten all mounting bolts with a wrench.

Fig. J

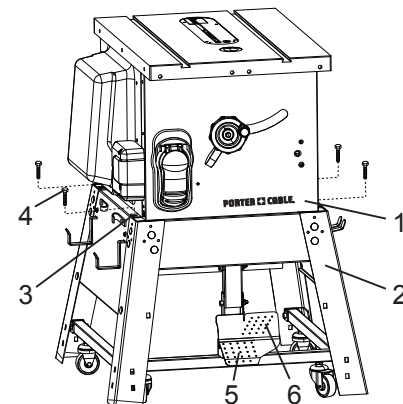

MOVING TABLE SAW AND STAND (FIG. J)

1. Tread on the area (5) of pedal to lift the saw and stand when stand legs contacting the level surface.
2. Move the saw and stand to the desired location by the caster assembly for operation or storage.
3. Tread on the area (6) of pedal to put the saw and stand on the ground.

INSTALLING THE ANTI-KICKBACK PAWL AND BLADE GUARD ASSEMBLY STORAGE (FIG. K)

Storage brackets for anti-kickback pawl and blade guard assembly are located on the right side of the saw base.

1. **Bag “J, K”** - Insert the bracket (1) into the left slot (2) on the right side of saw base, attach the brackets by using two of six screws (22).
2. **Bag “J, K”** - Insert the support plate (4) into the right slot (5), attach the support plate by using two of six screws (22).

Fig. K

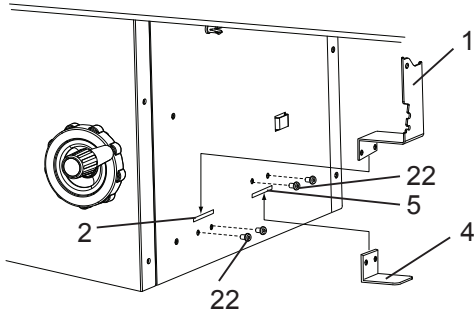

STORAGE (FIG. L ~ R)

Anti-kickback pawl storage (Fig. L)

Storage brackets for anti-kickback pawl (1) is located on the right side of the saw base.

1. Take the anti-kickback pawl assembly (1) and lift up the locking lever (2) located on top.
2. Place the front of assembly into slot (3) and push down making sure the assembly is engaged in the slot (3, 4). There should be no movement of the assembly. Push down on the locking lever.

Fig. L

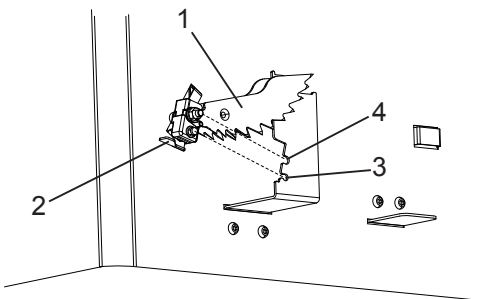

Blade guard assembly storage (Fig. M)

Storage brackets for blade guard assembly (1) is located on the right side of the saw base.

1. Take the blade guard assembly (1) and locate the sliding locking knob (2) on the back of assembly.
2. Slide the locking knob up and press the guard assembly down along the step (3) so that the ball engages into hole (4) completely.
3. Release the locking knob. Make sure that the assembly is locked in place and supported by plate (5).

Fig. M

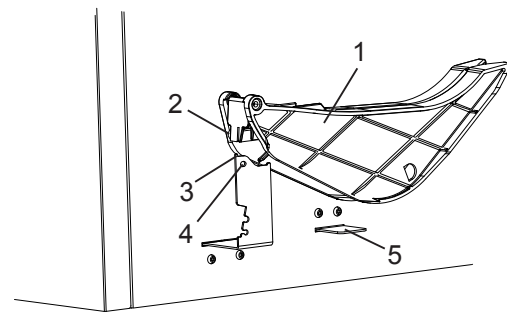

Blade wrench & push stick storage (Fig. N, O)

Storage for blade wrench and push stick is located on the right side of the saw base.

1. Hang the blade wrench (1) on the holder (2) as shown.

Fig. N

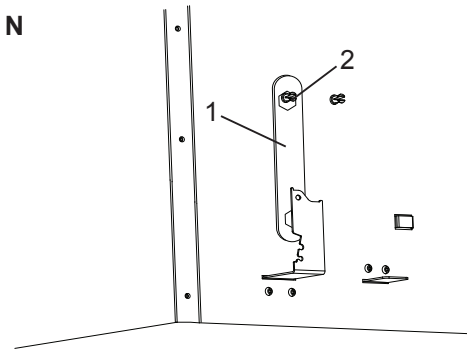

2. Insert the holders (2) through the holes (3) of the push stick (4).

Fig. O

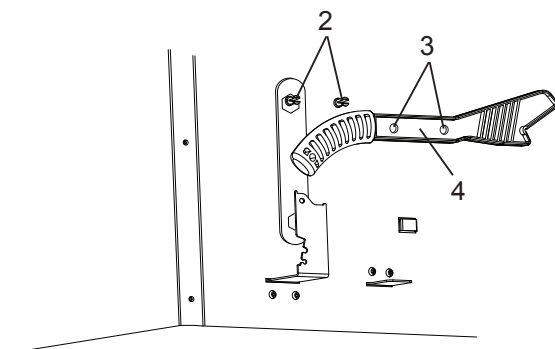

Riving knife storage (Fig. P)

Storage for riving knife (1) is located on the right side of the saw base. Insert the riving knife through the holder (2) as shown.

Fig. P

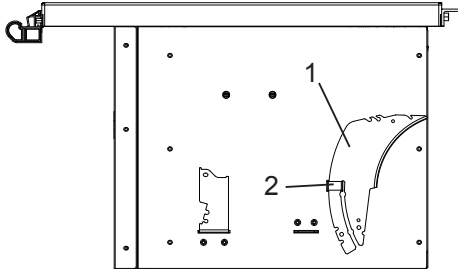

Miter gauge storage (Fig. Q)

Storage for miter gauge (1) is located on the right side of the stand. Hang the miter gauge on the hook (2).

Fig. Q

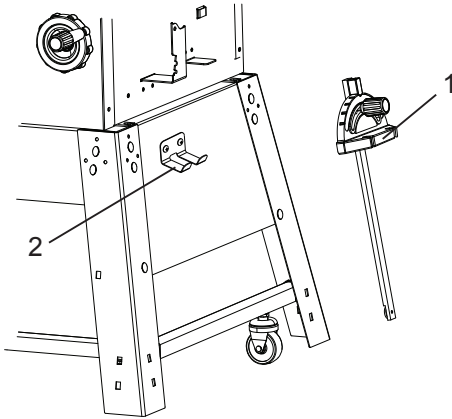

Rip fence storage (Fig. R)

Storage brackets for the rip fence (1) is located on the left side of the stand. Place the rip fence on the two hooks (2).

Power cord storage (Fig. R)

Storage for the power cord (3) is located on the left side of the stand. Wrap the power cord onto the brackets (4) when saw in not in use. This can prevent damage to the cord.

Fig. R

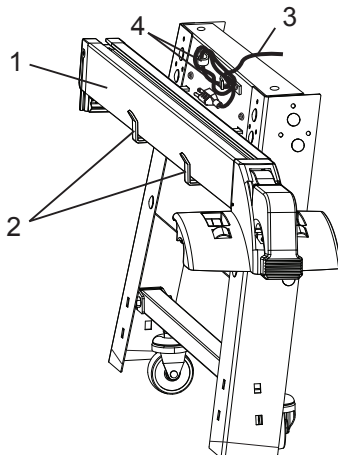

ASSEMBLING THE TABLE EXTENSION (FIG. S)

1. Place the left table extension next to the saw table, aligning the mounting holes (1).
2. **Bag "Q"** - Place three bolts with washers (2) and thread in mounting holes.
3. Place a straight edge or combination square on the saw table, across the table extension.
4. Adjust the mounting bolts (2) until the extension is flush with the saw table, and tighten.
NOTE: Extensions will not be flush on outer edges at this time until rails are installed.
5. Repeat these procedures for the right table extension.

Fig. S

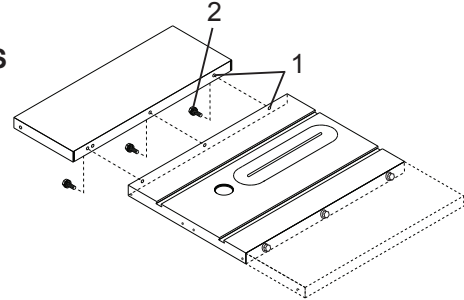

ASSEMBLING THE FRONT AND REAR TABLE RAIL (FIG. T, U)

Assembly the front rail (Fig. T)

1. Identify the right front rail (1) and the left front rail (2) by rail scales (3).
2. **Bag "R"** - Attach the right front side cover (4) into right front table rail (1). Repeat for the left front rail.
3. **Bag "S"** - Place four long hex bolts (5), two short hex bolts (6) through the holes at the front table edge. Screw the square nuts (7) onto each bolts.
NOTE: Keep the bolts and square nuts loosened before attaching front rail.
4. Attach the right front rail onto proper location by having the square nuts pass through the slot of the front rail. Repeat for the left front rail.
5. Attach the middle plug (8) to connect the two front rail halves.
6. With the blade installed, use the rip fence and gauge to adjust the front rail to proper location. When the front rail is level with table, then fix the front rail by tightening the six bolts. **NOTE:** Place straight edge across table and extension and lift rail until edge is flush, then tighten bolts. Repeat for other side.

Fig. T

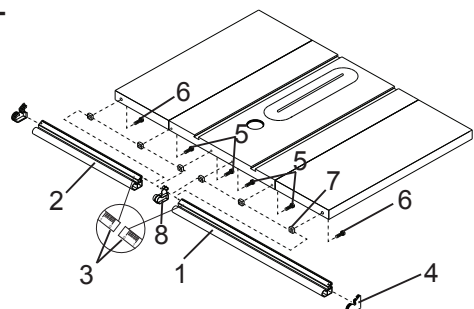

Assembling the rear rail (Fig. U)

1. Identify the right rear rail (1) and the left rear rail (2). The right rear rail is longer.
2. Place the rear rail on the saw table, aligning with the holes in each rail.
3. **Bag "T"** - Place six hex bolts (3), two nuts (4) and thread into the holes; tighten the bolts and check the alignment again.

Fig. U

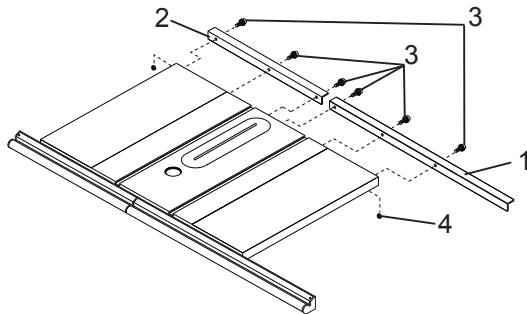

BLADE TILTING HANDWHEEL (FIG. V)

1. **Bag "U"** - Attach the blade tilting handwheel (1) to the tilting shaft (2) at the front of the saw.
2. Attach and tighten the dome nut (3) at the end of the shaft.

BLADE ELEVATION HANDWHEEL (FIG. V)

1. Insert the hex nut (4) into the hole (5) located on the rear of the blade elevation handwheel (6), thread the handle (7) into the handwheel (6) and tighten.

Fig. V

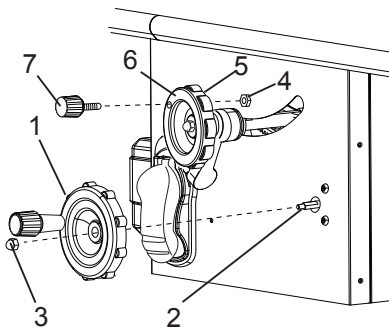

REMOVING THE BLADE (FIG. W)

⚠ WARNING

To avoid injury from an accidental start, make sure the switch is in the OFF position and the plug is disconnected from the power source outlet.

1. Remove the table insert and raise the blade to the maximum height by turning the blade elevation handwheel clockwise.
NOTE: there is a "finger hole" in the insert that is used for removing the insert.
2. Adjust the blade to the 90° vertical position by unlocking the blade tilting lock handle and turning the blade tilting handwheel counterclockwise, and then lock into position.

3. Pull the motor locking lever (1) toward the front of the machine while spinning the blade until the latch locks into place and the blade will no longer turn.
4. Place the blade wrench (2) on the arbor nut (3).
5. Loosen and remove the arbor nut and the flange (4) by pulling the wrench toward the front of the machine.
6. Then remove the blade (5). Clean but do not remove the inner blade flange before reassembling the blade.

Fig. W

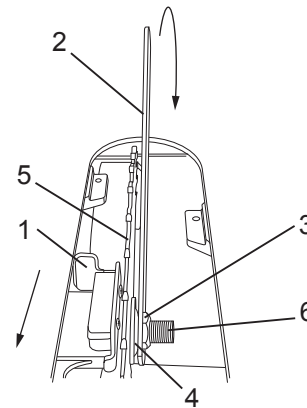

INSTALLING A BLADE (FIG. W)

⚠ WARNING

To avoid injury from an accidental start, make sure the switch is in the OFF position and the plug is disconnected from the power source outlet.

1. Place the blade (5) onto the arbor (6) with the blade teeth pointing forward to the front of the saw.
2. Make sure the blade fits flush against the inner flange.
3. Clean the outer blade flange (4) and install it onto the arbor and against the blade.
4. Thread the arbor nut (3) onto the arbor, making sure the flat side of the nut is against the blade, then handtighten.
5. Pull the motor locking lever (1) toward the front of the machine while spinning the blade until the latch locks into place and the blade will no longer turn.
6. Place the wrench (2) on the arbor nut and turn clockwise (toward the rear of the saw table).
7. Replace the table insert.

ADJUSTING THE 90° AND 45° POSITIVE STOPS (FIG. X, Y, Z)

Your saw has positive stops that will quickly position the saw blade at 90° and 45° to the table. Make adjustments necessary.

90° Stop (Fig. X, Y)

1. Disconnect the saw from the power source.
2. Turn the blade tilting handwheel until the blade tilting scale is at 90°.
3. Turn the blade elevation handwheel and raise the blade (1) to the maximum elevation.
4. Place a combination square (2) on the table and against the blade to check if the blade is 90° to the table.

Fig. X

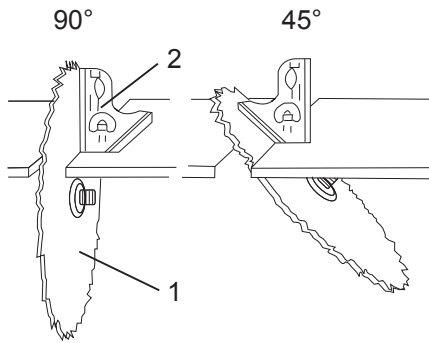

5. If the blade is not 90° to the table. Remove the back cover of the base by removing the screws, two for each side.
6. Adjust the blade tilting handwheel to make an adequate distance between the anchor block (1) and bevel gear (2).
7. Loosen the two set screws (3) of the anchor block with 3 mm hex key.
8. Separate the anchor block (1) from the worm (4).
 - When the bevel angle is more than 90°, turn the anchor block to A direction in adequate degree until the bevel angle and bevel scale is the same.
 - When the bevel angle is less than 90°, turn the anchor block to B direction in adequate degree until the bevel angle and bevel scale is the same.
9. When completing the above adjustment, replace the set screws and tighten them.
10. Replace the back cover and then tighten the screws.

Fig. Y

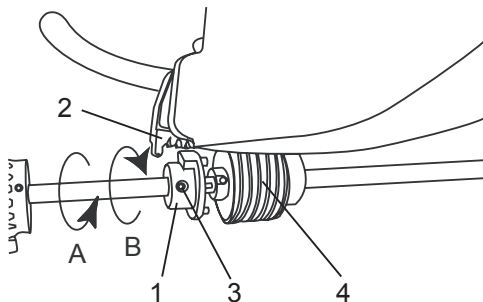

45° Stop (Fig. X, Z)

1. Turn the blade tilting handwheel until the blade tilting scale is 45°.
2. Turn the blade elevation handwheel and raise the blade to the maximum elevation.
3. Place a combination square on the table and against the blade to check if the blade is 45° to the table.
4. If the blade is not 45° to the table. Remove the back cover of the base by removing the screws, two for each side.
5. Adjust the blade tilting handwheel to make an adequate distance between the anchor block (1) and bevel gear (2).
6. Loosen the two set screws (3) of the anchor block with 3 mm hex key.
7. Separate the anchor block from the worm (4).
 - When the bevel angle is more than 45°, turn the anchor block to A direction in adequate degree until the bevel angle and bevel scale is the same.
 - When the bevel angle is less than 45°, turn the anchor block to B direction in adequate degree until the bevel angle and bevel scale is the same.
8. When completing the above adjustment, replace the set screws and tighten them.
9. Replace the back cover and then tighten the screws.

Fig. Z

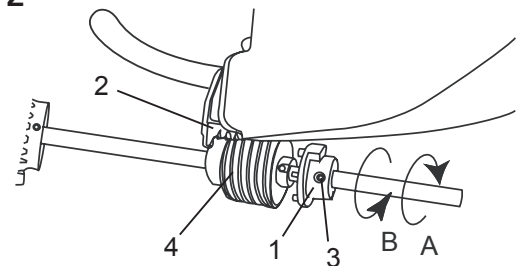

BLADE TILTING INDICATOR (FIG. AA)

NOTE: This is located on the top of the table, in front of the blade guard

1. When the blade is positioned at 90°, adjust the blade tilt pointer to read 0° on the scale.
2. Remove the magnifier cover (1) by removing the two screws (2). Position the pointer over 0° and replace the magnifier cover and replace the screws

NOTE: Make a trial cut on scrap wood before making critical cuts. Measure for accuracy.

Fig. AA

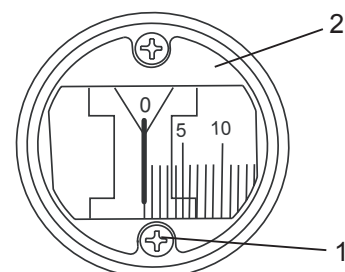

INSTALLING THE TABLE INSERT (FIG. BB, CC)

NOTE: The table insert has been previously installed on your unit. However, you must verify that the table insert is flush with the table top surface on all four corners of the insert.

1. Insert the spring clip (1) under the table, and push the table insert (2) to be flush with the table.
2. If the table insert is not flush with the table, adjust the four screws (3) with a screwdriver until it is parallel with the table.

NOTE: To raise the insert, turn the screws counterclockwise, to lower the insert, turn the screws clockwise.

Fig. BB

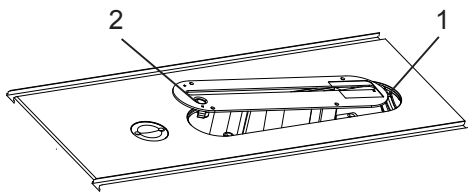
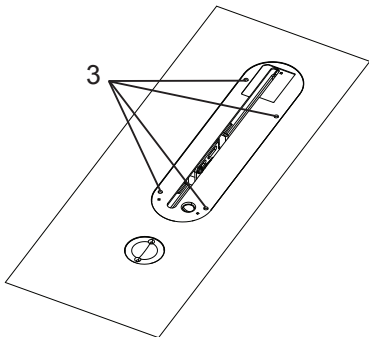

Fig. CC



INSTALLING THE RIVING KNIFE (FIG. DD)

1. Remove the table insert.
2. With the blade elevation handwheel, raise the blade arbor to the maximum height.
3. Loosen the riving knife lock knob (1) (minimum of three turns).
4. To disengage riving knife lock pin, push lock knob toward the riving knife (2) as indicated by the arrows on the knob.
5. Insert the riving knife into the the space (3).
6. Slide the riving knife to the approximate position and the lock pin will snap into place.
7. Tighten the riving knife lock knob.

⚠ WARNING

Before connecting the table saw to the power source or operating the saw, always inspect the blade guard assembly and riving knife for proper alignment and clearance with saw blade. Check alignment after each change of bevel angle.

NOTE: DO NOT operate saw if riving knife is not locked in the thru-cut or non thru-cut position hole.

Fig. DD

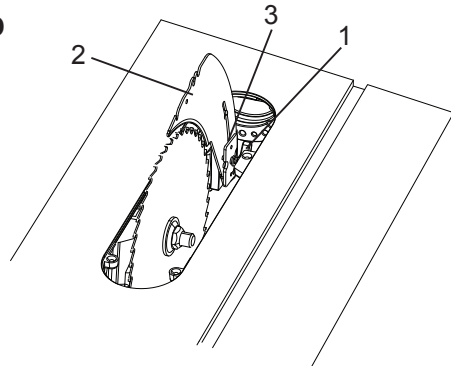

ALIGNING THE RIVING KNIFE TO BLADE (FIG. DD, EE)

⚠ WARNING

- To avoid injury from an accidental start, make sure the switch is in the OFF position and the plug is disconnected from the power source outlet.
- Never operate this tool without the riving knife in the correct position.
- Never operate this tool without the blade guard in place for all through sawing operations.
- This adjustment was made at the factory, but it should be rechecked and adjusted if necessary.

1. Remove the table insert and raise the blade to the maximum height by turning the blade elevation handwheel clockwise.
2. Remove the blade guard and anti-kickback pawl assembly.
3. Adjust the blade to the 0° vertical position by unlocking the blade tilting lock handle and turning the bevel tilting handwheel counterclockwise, and then lock into position.
4. To see if the blade (1) and riving knife (2) are correctly aligned, lay a combination square (3) along the side of the blade and against the riving knife (making sure the square is between the teeth of the blade).
5. Tilt the blade to the 45° position and check the alignment again.

Fig. DD

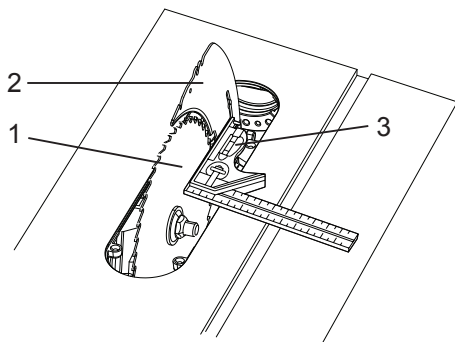

6. If the blade and riving knife are not correctly aligned, adjustment is needed.
7. Loosen the two larger lock screws (4).
8. Locate the four small set screws (5) adjacent to the riving knife lock knob (6). Adjust the small set screws to move the riving knife according to the position noted in step 4. Lay the combination square on the opposite side of the blade and repeat adjustment as needed.
9. Lightly tighten the two larger lock screws.
10. Place a square flat against the riving knife to verify riving knife is vertical and in line with the blade.
11. If needed, use the set screws to bring the riving knife vertical with the square.
12. Repeat steps 7 and 8 to verify position of riving knife.
13. Fully tighten the two larger lock screws.

Fig. EE

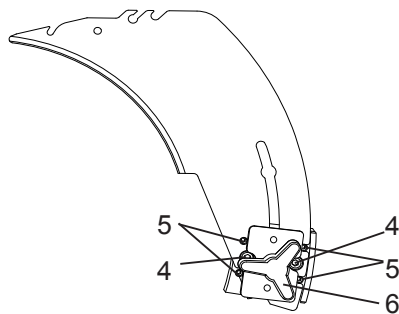

NOTE:

- This table saw is provided with a 10 in. diameter blade with a body thickness of 1.8 mm (0.07 in.) thick with a kerf of 2.6 mm (0.1 in.). The riving knife is 2.2 mm (0.09 in.) thick. The blade diameter and the blade body and kerf dimensions must be properly matched with the riving knife thickness.
- The maximum radial distance between the riving knife and the toothed rim of the saw blade is 0.12 in. ~ 0.31 in. (3 mm ~ 8 mm)
- The tip of the riving knife shall not be lower than 0.04 in. ~ 0.2 in. (1 mm ~ 5 mm) from the tooth peak.
- The riving knife is thinner than the width of the kerf by approximately 1/64 in. (0.4 mm) on each side.
- The blade body must be thinner than the thickness of the riving knife but the blade kerf must be thicker than the riving knife.

INSTALLING BLADE GUARD ASSEMBLY (FIG. FF, GG)

⚠ WARNING

To avoid injury from an accidental start, make sure the switch is in the OFF position and the plug is disconnected from the power source outlet.

- When installing the blade guard, cover the blade teeth with a piece of folded cardboard to protect yourself from possible injury.
- Never operate this machine without the blade guard in place for all through sawing operations.

Installing the anti-kickback pawl and blade guard assembly (Fig. FF)

1. Make sure the blade is elevated to its maximum height and the bevel is set at 0°. Make sure the bevel lock handle is tight.
2. Take the anti-kickback pawl assembly (1) and lift up the locking lever (2) located on top.
3. Place the front of assembly into slot (3) and push down making sure the assembly is engaged in the slot (3, 4). There should be no movement of the assembly. Push down on the locking lever.

Fig. FF

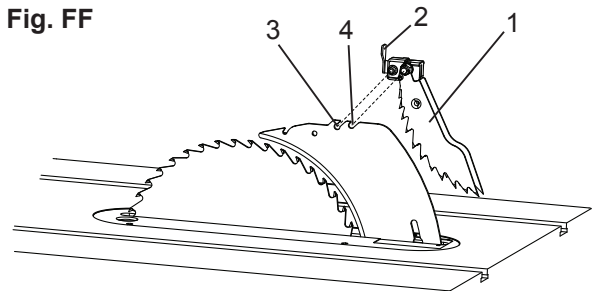

4. Take the blade guard assembly (5) and locate the sliding locking knob (6) on the back of assembly.
5. Insert the blade guard assembly onto the riving knife so that the pin (7) engages into slot (8) completely.
6. Slide the locking knob (6) up and press the guard assembly down so that the entire assembly is flat on the riving knife. Release the locking knob.
7. Make sure that the assembly is locked in place both in front and back.

Fig. GG

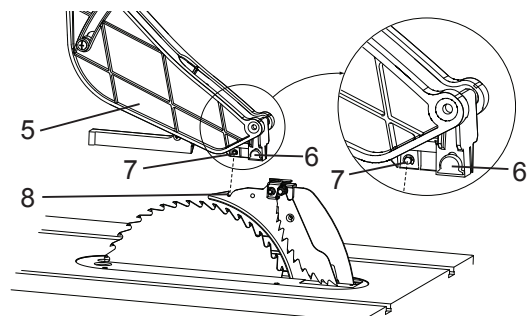

Removing the blade guard and anti-kickback pawl assembly (Fig. FF, GG)

⚠ WARNING

To avoid injury from an accidental start, make sure the switch is in the OFF position and the plug is disconnected from the power source outlet.

1. With the blade elevation handwheel raise the blade to the maximum height.
2. Loosen the blade lock handle do not pull on handle just turn and move the handwheel to 90° on the bevel scale.
3. Tighten the bevel lock handle.
4. Remove the anti-kickback pawl assembly (1) by lifting the locking lever (2).
5. Remove the blade guard assembly (5) by pulling up on the locking knob (4).

AVOID KICKBACKS

(Work thrown back towards you) by keeping the blade sharp, the rip fence parallel to the saw blade and by keeping the riving knife, anti-kickback pawls and guards in place, aligned and functioning. Do not release work before passing it completely beyond the saw blade. Do not rip work that is twisted, warped or does not have a straight edge to guide it along the fence. Do not attempt to reverse out of a cut with the blade running.

⚠ WARNING

Improper riving knife alignment can cause “kickback” and serious injury.

INSTALLING THE MITER GAUGE

Insert the miter gauge bar into the table top grooves. Make sure that the miter gauge bar slides freely through the table top grooves.

ADJUSTING THE MITER GAUGE (FIG. HH)

The miter gauge is accurately constructed with index stops at 0°, 15°, 30°, 45°, 60° both right and left sides.

1. Loosen the lock handle (1) to allow the miter body (2) to rotate freely. Position the miter body at 90° so the positive detent secures its position. Tighten the lock handle to hold the miter body in position.
2. If the pointer (3) requires adjustment, loosen the screw under the pointer with a screwdriver. Adjust the pointer to 90° on the scale, then firmly tighten the adjustment screw.
3. To change angles on the miter gauge, loosen the lock handle (1) and rotate the miter body to the desired angle as indicated by the scale. Secure in position by tightening the lock handle.

Fig. HH

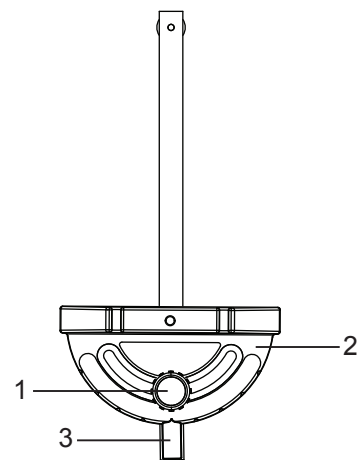

INSTALLING THE RIP FENCE (FIG. II)

1. Lift upward on the rip fence handle (1) so the rear holding clamp (2) is fully extended.
2. Place the rip fence on the saw table and engage the holding clamp to the rear rail (3). Lower the front end into the front rail (4).
3. Push down on the rip fence handle to lock.

Fig. II

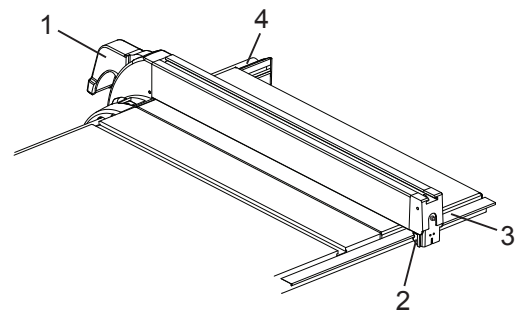

RIP FENCE ADJUSTMENT (FIG. JJ)

1. The fence (1) is moved by lifting up on the handle (2) and sliding the fence to the desired location. Pushing down on the handle locks the fence in position.
2. Position the fence on the right side of the table and along the edge miter gauge groove (3).
3. Lock the fence handle. The fence should be parallel with the miter gauge groove.
4. If adjustment is needed to make the fence parallel to the groove, do the following:
 - Loosen the two bolts (4) and lift up on the handle.
 - Hold the fence bracket (5) firmly against the front of the saw table. Move the fence until it is parallel with the miter gauge groove.
 - Push the handle down and tighten both bolts.

5. If fence is loose when the handle is in the locked (downward) position, do the following:
 - Move the handle upward and turn the adjusting nut (6) clockwise until the rear clamp is snug.
 - Over-tightening the adjusting bolts will cause the fence to come out of alignment.

NOTE: Two rollers (7) are provided for fine adjustment, turning left or right.

Fig. JJ

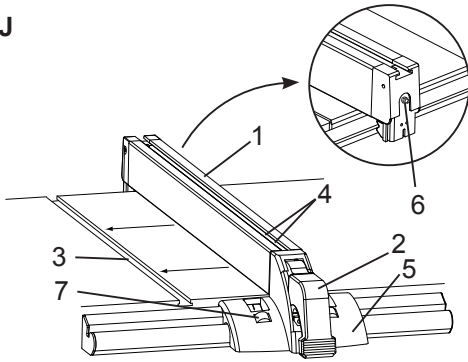

⚠ WARNING

Failure to properly align fence can cause “kickback” and serious injury.

RIP FENCE INDICATOR AJUSTMENT(FIG. KK)

NOTE: The rip fence indicator points to the scale on the front of the table saw. Measurement shown by the indicator will provide the user with accuracy up to 1/16 in. (1.6 mm). Measurement shown is the distance from the blade to the side of the fence closest to the blade.

1. To check the accuracy, measure the actual distance to the side of the rip fence. If there is a difference between the measurement and the indicator, an adjustment of indicator (1) is needed.
2. Loosen the indicator screws (2). Slide the indicator to the correct measurement position on the scale (3), then retighten the indicator screws.

Fig. KK

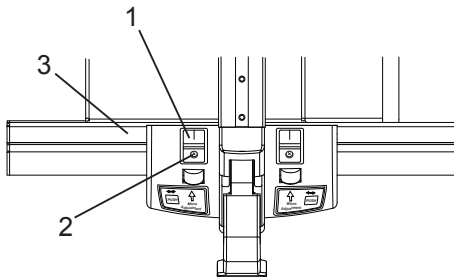

OPERATION

BASIC SAW OPERATIONS

NOTE: The table top surfaces should be cleaned to remove the protective coating that it is shipped with before using the saw.

RAISING THE BLADE (FIG. LL)

To raise or lower the blade, turn the blade elevation handwheel (1) to the desired blade height.

Fig. LL

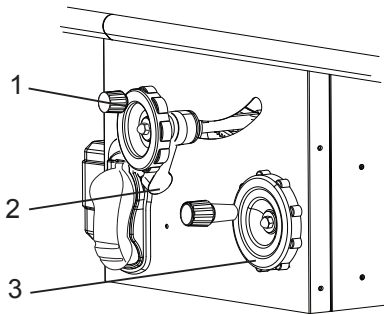

TILTING THE BLADE (FIG. LL)

1. To tilt the saw blade for bevel cutting, loosen the lock handle (2) by turning clockwise and turn the tilting hand wheel (3).
2. Tighten the lock handle (2) counterclockwise to secure.

ON/OFF SWITCH (FIG. MM)

The ON / OFF switch has a removable safety key. With the key removed from the switch, unauthorized and hazardous use by children and others is minimized and the saw will not turn on.

1. Lift the switch cover (1).
2. To turn the table saw ON, insert the black key (2) into the key slot in the center of the switch (3).
3. Push the key firmly into the slot, then pull switch up to the ON position to start the table saw.
4. To turn the table saw OFF push the switch to the down position. **NOTE:** The switch cover is designed to allow the saw to be turned off by pressing on the cover either with a hand or knee.
5. Remove black safety key when saw is not in use to prevent unauthorized usage.

Fig. MM

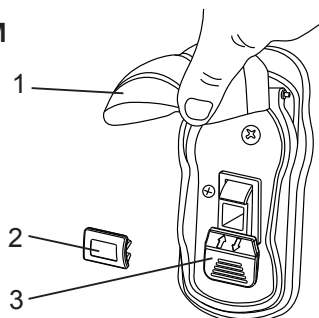

OVERLOAD PROTECTION (FIG. NN)

This saw has an overload reset button (1) that resets the motor after it shuts off due to overloading or low voltage. If the motor stops during operation, turn the ON / OFF switch to the OFF position. Wait about five minutes for the motor to cool, push in on the reset button (1) and turn the switch to the ON position.

Fig. NN

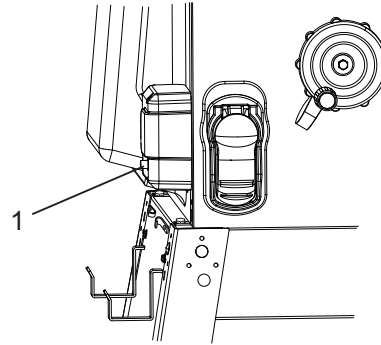

USING THE DUST PORT (FIG. OO)

⚠ WARNING

To prevent fire hazard, clean and remove sawdust from under the saw frequently.

The sawdust port has a 2-1/2 in. (63.5 mm, O.D.) diameter opening, suitable for attaching to a wet/dry vacuum hose to help keep the work area free of sawdust.

To prevent sawdust buildup inside the saw housing, attach a vacuum hose (1) to the dust port (2) at the rear of the table saw. **DO NOT** operate the saw with the hose in place unless the vacuum is turned on.

Fig. OO

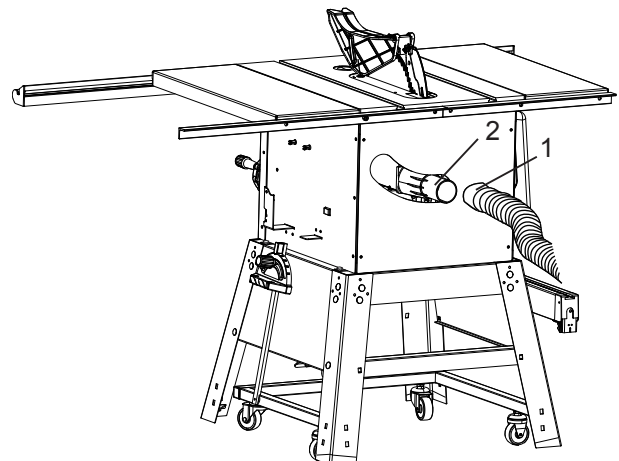

CUTTING OPERATIONS

There are two basic types of cuts: ripping and crosscutting. Ripping is cutting along the length and the grain of the workpiece. Crosscutting is cutting either across the width or across the grain of the workpiece. Neither ripping nor crosscutting may be done safely freehand. Ripping requires the use of the rip fence, and crosscutting requires the miter gauge.

⚠ WARNING

Before using the saw each and every time, check the following:

1. The blade is tightened to the arbor.
2. The bevel angle lock knob is tight.
3. If ripping, the fence is locked into position and is parallel to the miter gauge groove.
4. The blade guard is in place and working properly.
5. Safety glasses are being worn.
6. Make sure casters are released in the up position and that all four legs are resting evenly on the floor.

The failure to adhere to these common safety rules, and those printed in the front of this manual, can greatly increase the likelihood of injury.

RIPPING (FIG. PP)

⚠ WARNING

To prevent serious injury:

- **Never use a miter gauge when ripping.**
- **Do not allow familiarity or frequent use of your table saw to cause careless mistakes. Remember that even a careless fraction of a second is enough to cause a severe injury.**
- **Keep both hands away from the blade and clear from the path of the blade.**
- **The workpiece must have a straight edge against the fence and must not be warped, twisted, or bowed when ripping.**

1. Remove the miter gauge, and hang it on the miter gauge storage located on the right side of stand.
2. Secure the rip fence to the table.
3. Raise the blade so it is about 1/8 in. (3.2 mm) higher than the top of the workpiece.
4. Place the workpiece flat on the table and against the fence. Keep the workpiece away from the blade.
5. Turn the saw ON and wait for the blade to come to full speed.
6. Slowly feed the workpiece into the blade by pushing forward only on the workpiece section (1) that will pass between the blade and the fence.

⚠ WARNING

AVOID KICKBACK by pushing forward on the section of the workpiece that passes between the blade and the fence. Never perform any freehand operations.

Fig. PP

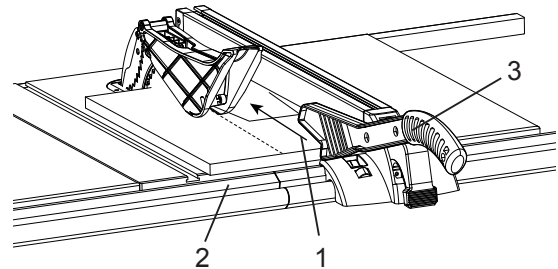

NOTE: Always use a push stick. When width of the rip is narrower than 2 in. (50.8 mm) the push stick cannot be used because the guard will interfere. Therefore, use the auxiliary fence so the push stick can be used as shown on page 32.

7. Keep your thumbs off the table top. When both of your thumbs touch the front edge of the table (2), finish the cut with a push stick. To make an additional push stick, use the pattern on page 32.
8. The push stick (3) should always be used.
9. Continue pushing the workpiece with the push stick until it passes through the blade guard and clears the rear of the table.
10. Never pull the piece back when the blade is turning. Turn the switch OFF. When the blade completely stops, you can then remove the workpiece.

BEVEL RIPPING

This cut is the same as ripping except the blade bevel angle is set to an angle other than 0°.

SETTING BEVEL ANGLE (FIG. QQ)

1. To set the bevel angle, loosen the blade bevel lock handle (1) which is the handle on the blade elevation handwheel (2), and then turn the blade tilting handwheel (3) counterclockwise to bevel the blade to the left. Turn the blade tilting handwheel (3) clockwise to return the blade to the vertical position.
2. To lock the blade at the required bevel setting, turn the blade bevel lock handle (1) counterclockwise. Always release the blade bevel lock handle prior to changing the bevel setting and relock the handle after the required bevel angle is set.
3. If the blade bevel lock handle (1) interferes with the blade tilting handwheel (3) while it is being tightened the handle can be pulled forward to allow it to be

turned to a new position away from the blade tilting handwheel. Once in the new position release the handle and continue to tighten the handle.

Fig. QQ

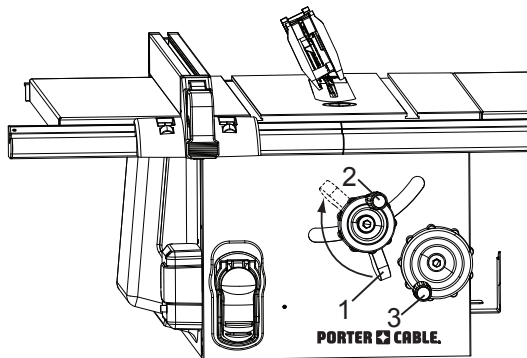

RIPPING SMALL PIECES

To avoid injury from the blade contact, never make cuts narrower than 1/2 in. (12.7 mm) wide.

1. It is unsafe to rip small pieces. Instead, rip a larger piece to obtain the size of the desired piece.
2. When a small width is to be ripped and your hand cannot be safely press between the blade and the rip fence, use one or more push sticks to move the workpiece. Always use a push stick during ripping operations.

CROSSCUTTING (FIG. RR)

To prevent serious injury:

- Do not allow familiarity or frequent use of your table saw to cause careless mistakes. Remember that even a careless fraction of a second is enough to cause a severe injury.
- Keep both hands away from the blade and the path of the blade.

1. Remove the rip fence and place it on the hooks located on the left side of stand.
2. Place the miter gauge (1) either groove in the table top.
3. Adjust the blade height so it is 1/8 in. (3.2 mm) higher than the top of the workpiece (2).
4. Hold the workpiece firmly against the miter gauge with the blade path in line with the desired cut location. Move the workpiece to 1 in. (25.4 mm) distance from the blade (3).
5. Start the saw and wait for the blade to come up to full speed. Never stand directly inline of the saw blade path, always stand to the side of the blade that you are cutting on.

6. Keep the workpiece against the face of the miter gauge and flat against the table. Then slowly push the workpiece through the blade.
7. Do not try to pull the workpiece back with the blade turning. Turn the switch OFF, and carefully slide the workpiece out when the blade is completely stopped.

⚠ WARNING

Always position the larger surface of the workpiece on the table when crosscutting and/or bevel crosscutting to avoid instability.

Fig. RR

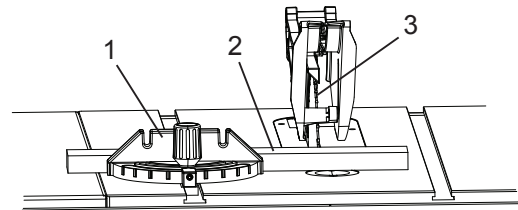

USING WOOD FACING ON THE MITER GAUGE (FIG. SS)

Slots are provided in the miter gauge for attaching an auxiliary facing (1) to make it easier to cut very long or short pieces. Select a suitable piece of smooth wood, drill two holes through it and attach it to the miter gauge with screws. Make sure the facing does not interfere with the proper operation of the sawblade guard. When cutting long workpieces, you can make a simple outfeed support by clamping a piece of plywood to a sawhorse.

Fig. SS

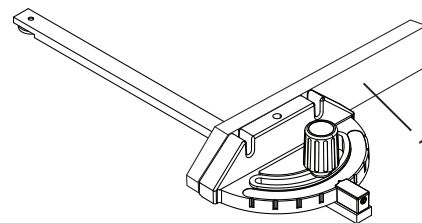

BEVEL CROSSCUTTING (FIG. TT)

This cutting operation is the same as crosscutting except the blade is at bevel angle other than 0°.

⚠ WARNING

Always work to the right side of the blade during this type of cut. The miter gauge (1) must be in the right side groove (4) because the bevel angle may cause the blade guard to interfere with the cut if used on the left side groove.

1. Adjust the blade (3) to the desired angle, and tighten the blade bevel lock handle.
2. Tighten miter lock handle at 90°.
3. Hold workpiece (2) firmly against the face of the miter gauge throughout the cutting operation.

Fig. TT

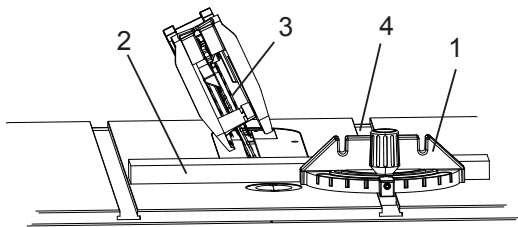

COMPOUND MITER CROSSCUTTING (FIG. UU)

This sawing operation is combining a miter angle with a bevel angle.

⚠ WARNING

Always work to the right side of the blade during this type of cut. The miter gauge (1) must be in the right side groove (4) because the bevel angle may cause the blade guard to interfere with the cut if used on the left side groove.

1. Set the miter gauge to the desired angle.
2. Place the miter gauge in the right side groove of the table.
3. Set the blade (3) bevel to the desired bevel angle and tighten the blade bevel lock handle.
4. Hold workpiece (2) firmly against the face of the miter gauge throughout the cutting operation.

Fig. UU

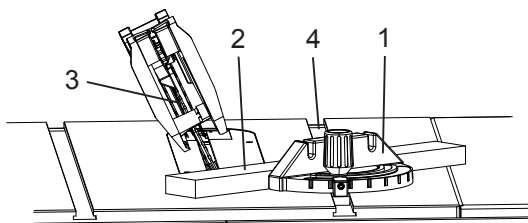

MITER CUTS (FIG. VV)

This sawing operation is the same as crosscutting except the miter gauge is locked at an angle other than 90°.

1. Set the blade (3) to 0° bevel angle and tighten the blade bevel lock handle.
2. Set the miter gauge (1) at the desired miter angle and lock in position by tightening the miter gauge locking handle.
3. Hold the workpiece (2) firmly against the face of the miter gauge throughout the cutting operation.

Fig. VV

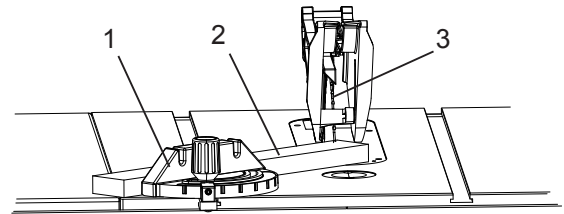

USING WOOD FACING ON THE RIP FENCE (FIG. WW)

When performing some special cutting operations, add a wood facing (1) to either side of the rip fence (2).

1. Use a smooth straight 3/4 in. (19.1 mm) thick wood board (1) that is as long as the rip fence.
2. Attach the wood facing to the fence with wood screws (3) (not included) through the holes in the fence. A wood fence should be used when ripping material such as thin paneling to prevent the material from catching between the bottom of the fence and the table.

Fig. WW

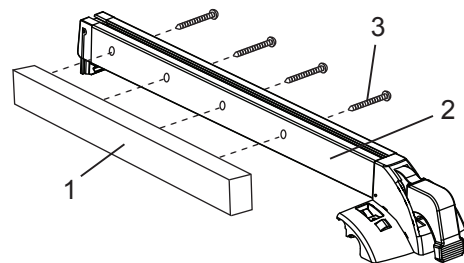

DADO CUTS (FIG. XX)

1. To perform dado cutting with a stacked dado blade set a special insert must be used. See page 30 and 31 for ordering information. Remove the saw blade, original table insert and blade guard. Install the dado and dado blade insert.
2. Instruction for operating the dado is packed with the separately purchased dado set. (not included with unit)
3. The arbor (1) on this saw restricts the maximum width of the cut to 13/16 in. (20.6 mm).
4. When making full 13/16 in. (20.6 mm) dado cuts, it is not necessary to install the outside flange (2) before screwing on the arbor nut (3). Make sure that the arbor nut (3) is tight, and that at least one thread of the arbor sticks out past the nut.
5. Do not exceed 8 inches (203.2 mm) diameter dados and keep the width 13/16 in. (20.6 mm) or less. It will be necessary to remove the blade guard and riving knife when using a dado blade. Always use caution when operating a dado blade.
6. Use only the correct number of round outside blades and inside chippers as shown in the dado set's instruction manual. Blade or chipper must not exceed 13/16 inch (20.6 mm).
7. Check saw to ensure that the dado will not strike the housing, insert, or motor when in operation.

⚠ WARNING

For your own safety, always replace the blade, blade guard assembly, and blade insert when you are finished with the dado operation.

Fig. XX

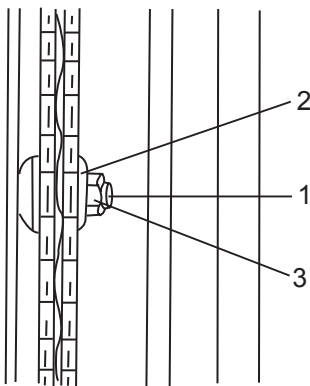

240V OPERATION CHANGING WIRES (FIG. YY, ZZ)

⚠ WARNING

To avoid injury, disconnect the motor from power source outlet before reconnecting the wire.

The table saw has a dual voltage, 120V and 240V, motor. To operate the table saw at 240V, single phase, please reconnect the motor wires as shown on page 28.

1. Remove the wire cover (1).

Fig. YY

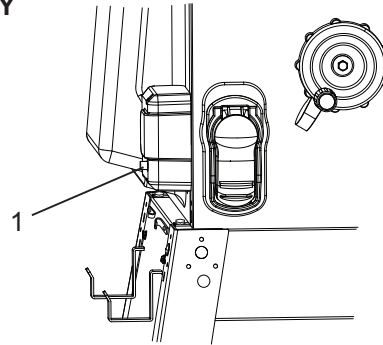

2. Reconnect the motor wires and power wires as shown in the wiring diagram Fig. ZZ.

⚠ CAUTION

A qualified electrician should do the conversion, or the machine can be taken to an Authorized Service Center. When completed, the machine must conform to the National Electric Code and all local codes and ordinances.

The machine is converted by re-wiring the motor for 240 volts, installing a 240 volt plug on the power supply cord and replacing the switch with one that is rated for 240 volt operation.

Be sure the 240 volt plug is only used in an outlet plug. No adapter should be used with the 240 volt plug. In all cases, make certain that the receptacle in question is properly grounded. If you are not sure, have a quali-

fied electrician check the receptacle.

NOTE: The 240 volt plug is not supplied with this product. Please check with a qualified electrician for the correct plug.

Fig. ZZ

120 V Wire Wiring

240 V Wire Wiring

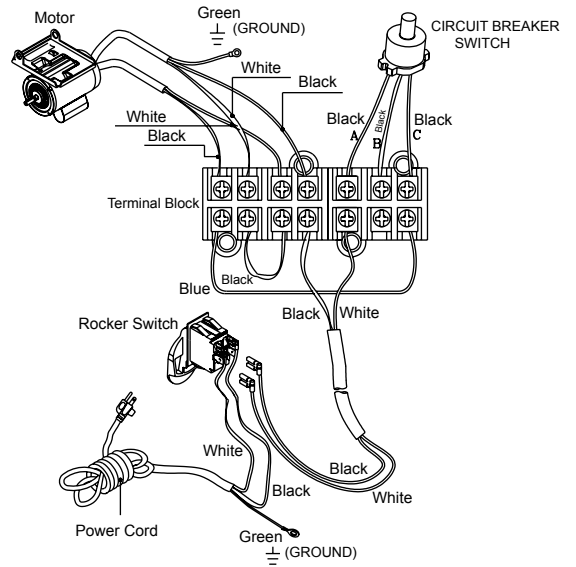
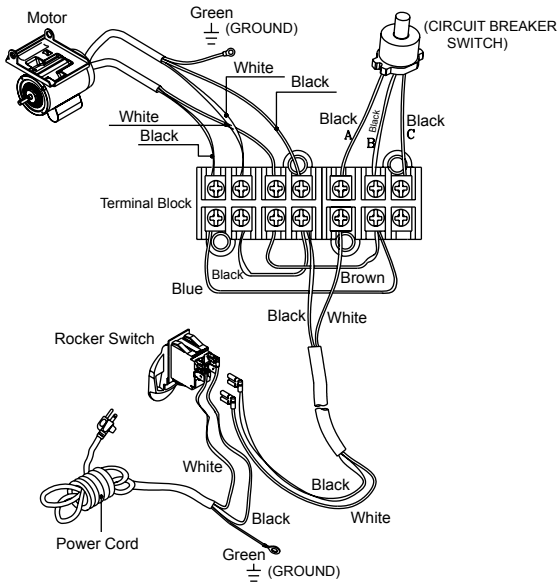
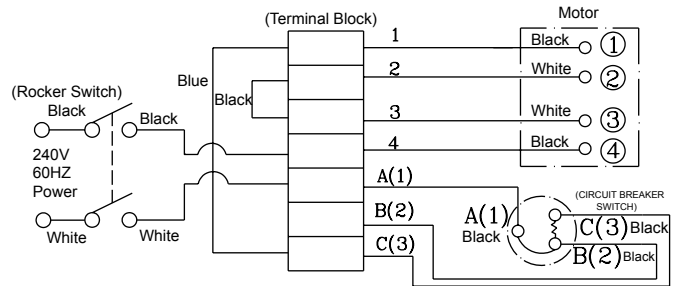
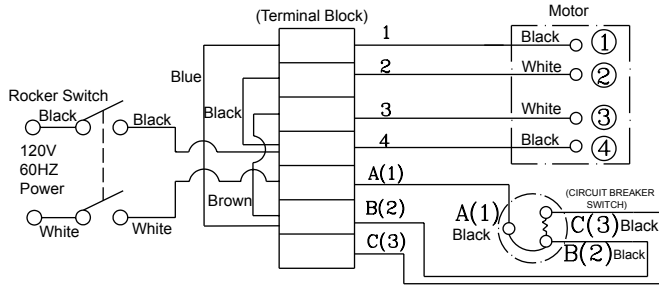

MAINTENANCE

MAINTAINING YOUR TABLE SAW

GENERAL MAINTENANCE

⚠ WARNING

For your own safety, turn the switch OFF and remove the switch key. Remove the plug from the power source outlet before maintaining or lubricating your saw.

1. Clean out all sawdust that has accumulated inside the saw cabinet and the motor.
2. Polish the saw table with an automotive wax to keep it clean and to make it easier to slide the workpiece.
3. Clean cutting blades with pitch and gum remover.
4. A worn, cut, or damaged power cord should be replaced immediately.

⚠ WARNING

All electrical or mechanical repairs should be attempted only by a trained repair technician. Contact the nearest Porter-Cable Authorized Service Center for service. Use only identical replacement parts. Any other parts may create a hazard.

5. Use only mild soap and a damp cloth to clean the tool. Never let any liquid get inside the tool; never immerse any part of the tool into a liquid.
IMPORTANT: To assure product SAFETY and RELIABILITY, repairs, maintenance and adjustment (other than those listed in this manual) should be performed by authorized service centers or other qualified service organizations, always using identical replacement parts.

NOTE: Certain cleaning chemicals can damage plastic parts.

6. Avoid use of cleaning chemicals or solvents, ammonia and household detergents containing ammonia.

LUBRICATION

All motor bearings are permanently lubricated at the factory and require no additional lubrication.

On all mechanical parts of your table saw where a pivot or threaded rod are present, lubricate using graphite or silicone. These dry lubricants will not hold sawdust as would oil or grease.

CHANGING DRIVE BELT (FIG. aa, bb)

⚠ WARNING

All electrical or mechanical repairs should be attempted only by a trained repair technician. Contact the nearest Porter-Cable Authorized Service Center for service. Use only identical replacement parts. Any other parts may create a hazard.

NOTE: Occasionally changing the drive belt may be necessary as a result of normal wear and use.

1. Unplug the unit from power source. Lower the blade to its lowest position. Turn the blade tilting handwheel until the blade tilting scale is around 45°.
2. Remove the rear body shell (1) and left body shell (2) by removing the twelve screws (3), slide the left body shell backwards.

Fig. aa

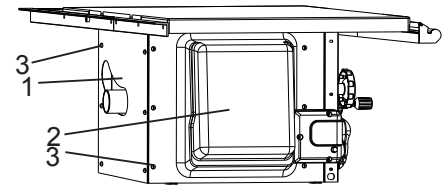

3. Turn the blade tilting handwheel until the blade tilting scale is around 0°.
4. Loosen four bolts (4) two full turns using a 6 mm hex key. Do not remove the bolts.
5. Rotate the motor (5) slightly to reduce the tension on the driven pulley (6). The three curved slots (7) allow for the movement of the motor.
6. Remove the old belt from the pulleys.
7. Fit the new belt on the motor pulley (8) first and then on the driven pulley (6). **NOTE:** Make sure the belt is fitted properly on the central position of pulleys.
8. Lower and rotate the motor (5) downwards away from the driven pulley (6) along the curved slots (7).
9. Tighten four bolts (4) securely.
10. Test the drive belt by hand and check to confirm that drive belt runs smoothly and straight on the pulleys.
11. Replace the rear body shell (1) and left body shell (2) with the screws (3).

Fig. bb

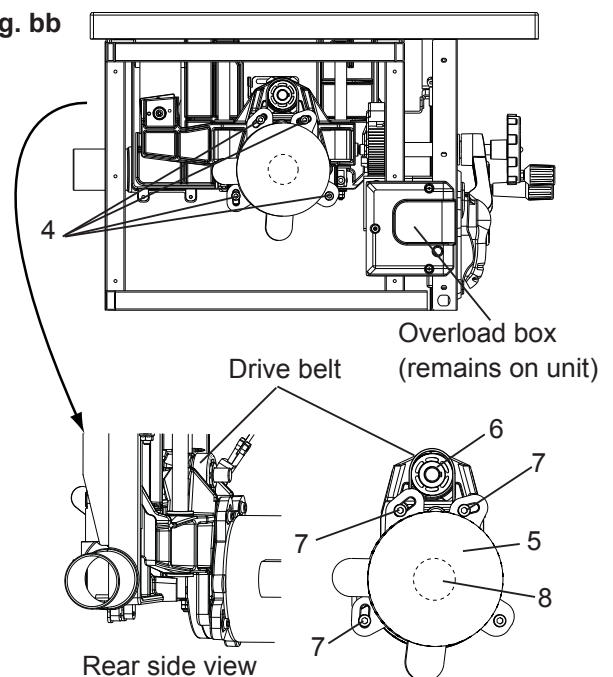

TROUBLESHOOTING GUIDE

WARNING

To avoid injury from an accidental start, turn the switch OFF and always remove the plug from the power source before making any adjustments.

REPLACEMENT PARTS

Use only identical replacement parts. For a parts list or to order parts, visit our service website at www.portercable.com. You can also order parts from your nearest Porter-Cable Factory Service Center or Porter-Cable Authorized Warranty Service Center. Or, you can call our Customer Care Center at (888) 609-9779.

SERVICE AND REPAIRS

All quality tools will eventually require servicing and/or replacement of parts. For information about Porter-Cable, its factory service centers or authorized warranty service centers, visit our website at www.portercable.com or call our Customer Care Center at (888) 609-9779. All repairs made by our service centers are fully guaranteed against defective material and workmanship. We cannot guarantee repairs made or attempted by others.

You can also write to us for information at Power Tool Specialists, Inc. 684 Huey Road, Rock Hill, SC 29730, (888) 609-9779 - Attention: Product Service. Be sure to include all of the information shown on the nameplate of your tool (model number, type, serial number, etc.).

PROBLEM	POSSIBLE CAUSES	CORRECTIVE ACTION
Saw will not start.	<ol style="list-style-type: none"> 1. Saw is not plugged in. 2. Fuse blown or circuit breaker tripped. 3. Cord is damaged. 	<ol style="list-style-type: none"> 1. Plug in saw. 2. Replace fuse or reset circuit breaker. 3. Have cord replaced by Porter-Cable Service Center or Authorized Service Station.
Does not make accurate 45° and 90° rip cuts.	<ol style="list-style-type: none"> 1. Positive stop not adjusted correctly. 2. Tilt angle pointer not set accurately. 	<ol style="list-style-type: none"> 1. Check blade with square and adjust positive stop. 2. Check blade with square and adjust to zero.
Material pinched blade when ripping.	<ol style="list-style-type: none"> 1. Rip fence not aligned with blade. 2. Warped wood, edge against fence is not straight. 	<ol style="list-style-type: none"> 1. Check and adjust rip fence. 2. Select another piece of wood.
Material binds on riving knife.	<ol style="list-style-type: none"> 1. Riving knife not aligned correctly with blade. 	<ol style="list-style-type: none"> 1. Check and align riving knife with blade.
Saw makes unsatisfactory cuts.	<ol style="list-style-type: none"> 1. Dull blade. 2. Blade mounted backwards. 3. Gum or pitch on blade. 4. Incorrect blade for work being done. 5. Gum or pitch on blade causing erratic feed. 	<ol style="list-style-type: none"> 1. Replace blade. 2. Turn the blade around. 3. Remove blade and clean with turpentine and coarse steel wool. 4. Change the blade. 5. Clean table with turpentine and steel wool.
Material kicked back from blade.	<ol style="list-style-type: none"> 1. Rip fence out of adjustment. 2. Riving knife not aligned with blade. 3. Feeding stock without rip fence. 4. Riving knife not in place. 5. Dull blade. 6. The operator letting go of material before it is past saw blade. 7. Miter angle lock knob is not tight. 	<ol style="list-style-type: none"> 1. Align rip fence with miter gauge slot. 2. Align riving knife with blade. 3. Install and use rip fence. 4. Install and use riving knife. (with guard) 5. Replace blade. 6. Push material all the way past saw blade before releasing work. 7. Tighten knob.

PROBLEM	POSSIBLE CAUSES	CORRECTIVE ACTION
Blade does not raise or tilt freely.	1. Sawdust and dirt in elevation/tilting mechanisms.	1. Brush or blow out loose dust and dirt.
Blade does not come up to speed. Reset trips too easily.	1. Extension cord too light or too long. 2. Low house voltage.	1. Replace with adequate size cord. 2. Contact your electric company.
Machine vibrates excessively.	1. Saw not mounted securely to workbench. 2. Bench on uneven floor. 3. Damaged saw blade.	1. Tighten all mounting hardware. 2. Reposition on flat level surface. 3. Replace blade.
Does not make accurate 45° and 90° crosscuts.	1. Miter gauge out of adjustment.	1. Adjust miter gauge.

For assistance with your product, visit our website at www.portercable.com for a list of service centers, or call the Porter-Cable Customer Care Center at (888) 609-9779.

ACCESSORIES AND ATTACHMENTS

ACCESSORIES

WARNING

Since accessories, other than those offered by Porter-Cable, have not been tested with this product, use of such accessories with this tool could be hazardous. To reduce the risk of injury, only Porter-Cable recommended accessories should be used with this product.

2WHW DADO INSERT PLATE

A complete line of accessories is available from your Porter-Cable Factory Service Center or a Porter-Cable Authorized Warranty Service Center. Please visit our Web Site www.portercable.com for a catalog or for the name of your nearest supplier.

WARNING

Do not use any accessory unless you have completely read the Instruction Manual for that accessory.

WARNING

To avoid the risk of personal injury:

- Do not use a dado with a diameter larger than 8 in. (203.2 mm).
- Maximum dado width is 13/16 in. (20.6 mm). DO NOT USE WIDER COMBINATIONS.
- Do not use molding head set with this saw.
- Do not modify this power tool.

PUSH STICK PATTERN

PUSH STICK CONSTRUCTION

- Use good quality plywood or solid wood
- Use 1/2 in. (13 mm) or 3/4 in. (19 mm) material
- Push stick MUST be thinner than the width of material being cut

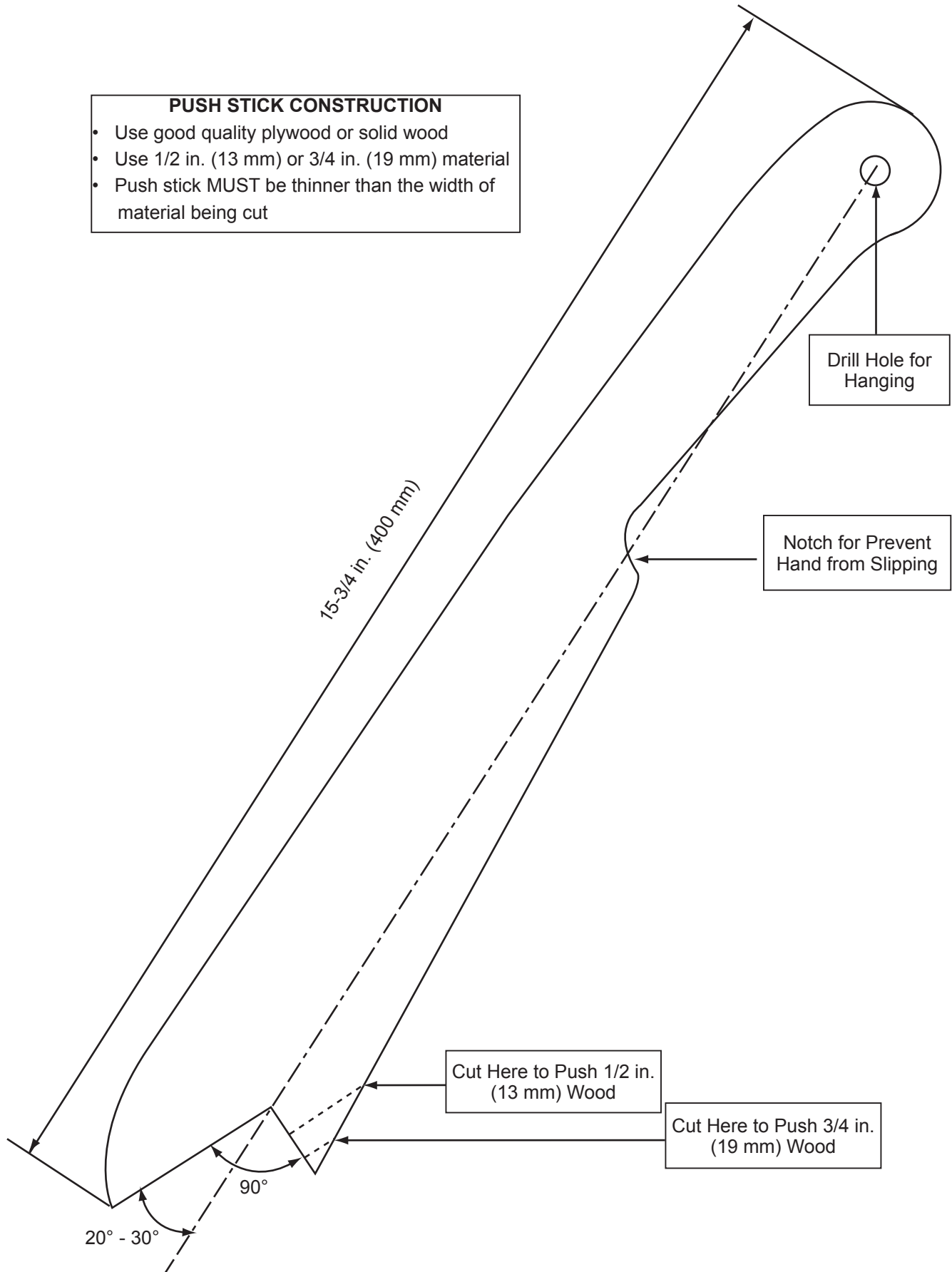

PARTS LIST

10 IN. (254 MM) STATIONARY TABLE SAW

PARTS LIST FOR TABLE SAW

I.D.	Description	Size	Qty	I.D.	Description	Size	Qty
2389	WHEEL	#06	1	26PT	COMPRESSION SPRING		1
2390	COMPRESSION SPRING		1	26VG	WIRE CONNECTOR		1
2552	HANDLE	#06	1	26VH	WIRE CONNECTOR		1
09JK	WRENCH		1	26YD	LEAD WIRE ASS'Y		1
0B98	BEVEL GEAR		1	26YE	LEAD WIRE ASS'Y		1
0BAC	SET NUT		1	26YF	LEAD WIRE ASS'Y		1
0BAE	ARBOR COLLAR		1	28DX	WORM		1
0GCM	BEVEL GEAR		1	28DY	BEVEL GEAR		2
0HVX	BALL BEARING		2	28RA	SWITCH BOX COVER		1
0J3V	WRENCH HEX.	6MM	1	28Z5	ANCHOR BLOCK		2
0J4D	FLAT WASHER	φ5*10-1	2	28Z7	CR. RE. COUNT HD. TAPPING SCREW		2
0J4F	FLAT WASHER	φ8*16-2.5	4	293H	PUSH STICK		1
0J4U	FLAT WASHER	φ6*18-1.5	1	297W	HARDWARE BAG ASS'Y - S		1
0J4W	FLAT WASHER	φ8.2*18-1.5	4	297Y	HARDWARE BAG ASS'Y - Q		1
0J5A	FLAT WASHER	φ5*16-2	1	2LXE	CIRCUIT BREAKER SWITCH ASS'Y		1
0J6T	FLAT WASHER	1/16*3/4-1/16	4	2NWX	DUST GUARD		1
0J78	FLAT WASHER	1/4*1/2-3/32	2	2PHA	CR. RE. TRUSS HD. TAPPING SCREW	M5*0.8-12	24
0J7U	FLAT WASHER	5/8*1 3/4-11/64	1	2PHX	HEX. SOC. TRUSS HD. SCREW	M5*0.8-8	2
0J8K	FLAT WASHER	1/4*3/4-1/16	1	2TUY	BLADE GUARD ASS'Y		1
0J8Z	FLAT WASHER	21/64X3/4-1/16	1	2UZU	SPACER		1
0J94	SPRING WASHER	φ8	4	2V3E	BLADE GUARD(RIGHT)		1
0JAF	EXTERNAL TOOTH LOCK WASHER	φ5	4	2W7L	CONNECTOR BOX		1
0JB2	WAVE WASHER	WW-12	2	2W7M	CONNECTOR BOX COVER		1
0JCH	SPRING PIN		5	2W7Q	BODY SHELL(R)	#GL	1
0JG4	PARALLEL KEY		2	2W7R	BODY SHELL(L)	#GL	1
0JP3	HEX. HD. BOLT	M8*1.25-12	6	2W7S	BODY SHELL(F)	#GL	1
0JPU	HEX. HD. BOLT	M8*1.25-20	4	2W7T	EXTENTION WING	#GL	2
0JUL	HEX. SOC. HD. CAP BOLT	M6*1.0-20	6	2W7U	REAR BRACKET	#06	2
0JX7	HEX. SOC. SET SCREW	M6*1.0-6	9	2W7V	TABLE	#GL	1
0K05	HEX. SOC. TRUSS HD. SCREW	M8*1.25-20	6	2W7W	DUST GUARD ASS'Y	#GM	1
0K19	HEX. HD. SCREW AND WASHER	M10*1.5-25	6	2W89	TABLE SUPPORT ASS'Y	#06	1
0K24	HEX SOC. HD. CAP SCREW	M8*1.25-35	4	2W8J	REAR RAIL(L)		1
0K2L	HEX.SOCKET HD.CAP SCREWS	M8*1.25-30	4	2W8K	REAR RAIL (R)		1
0K4T	CR.-RE. TRUSS HD. SCREW	M5*0.8-20	1	2W8M	BODY		1
0K5B	CR. RE. COUNT HD. SCREW	M6*1.0-12	2	2W8N	RACK		2
0K5T	CR. RE. COUNT HD. SCREW	M5*0.8-10	4	2W8P	CLAMP BAR		1
0K7D	CR. RE. ROUND WASHER HD. SCREW	M6*1.0-10	4	2W8Q	HEIGHT LEVER SEAT		1
0K7F	CR. RE. ROUND WASHER HD. SCREW	M5*0.8-8	8	2W8T	RIVING KNIFE		1
0K7K	CR. RE. ROUND WASHER HD. SCREW	M6*1.0-12	2	2W8U	DUST COLLECTOR		1
0K94	CR. RE. TRUSS HD. TAPPING SCREW	M5*12-16	1	2W8V	SET PLATE		1
0K9P	CR. RE. TRUSS HD. TAPPING SCREW	M6*14-12	1	2W8W	DUST COLLECTOR JOINT		1
0KA0	CR.RE. PAN HD. TAPPING SCREW	M5*12-20	2	2W8Z	ELEVATION SHAFT		1
0KAE	CR.RE. PAN HD. TAPPING SCREW	M5*0.8-10	4	2W90	CENTER SHAFT		1
0KB9	CR.RE. PAN HD. TAPPING SCREW	M5*16-10	7	2W91	CENTER SHAFT		1
0KC8	CR. RE. TRUSS HD. TAPPING SCREW	M4*16-16	7	2W93	SET BOLT	M8*1.25	6
0KFG	CR. RE. PAN HD. SCREW	M5*0.8-12	4	2W94	HEIGHT REGULATOR BOLT		1
0KK9	SLOTTED PAN HD.SCREW	M6*1.-20	2	2W95	LOCKING ROD		1
0KL1	CR.RE. PAN HD. ROUND NECK SCREW	M6*1.0-12	2	2WBS	RAIL (L)		1
0KMS	HEX. NUT	M6*1.0,T=5	3	2WBT	RAIL (R)		1
0KMT	HEX. NUT	M8*1.25,T=5	2	2WBU	MOTOR PULLEY		1
0KMY	HEX. NUT	M8*1.25,T=6.5	2	2WBV	PULLEY		1
0KN3	HEX. NUT	M16*1.5,T=10	1	2WCH	CUTTER SHAFT		1
0KNV	HEX. NUT	5/8*18UNF T=8	2	2WG1	HANDLE ASS'Y		1
0KQF	CROWN NUT	M8*1.25,T=18	2	2WGA	KNOB ELEVATION ASS'Y		1
0KQP	SQUARE NUT	M8*1.25 T=6.5	6	2WHH	BODY SHELL	#GL	1
0KQW	LOCK NUT	M5*0.8 T=5	3	2WJA	SET PLATE		1
0KQX	NUT	M6*1.0 T=6	3	2WJB	SET PLATE		1
0KRR	SERRATED TOOTHED HEXAGON FLANGE NUT	M8*1.25,T=7.5	4	2WWD	MOTOR ASS'Y		1
0KSC	STRAIN RELIEF		1	2X19	KICK BACK PAWL ASS'Y		1
0KTA	STRAIN RELIEF		5	2X1A	MITER GAUGE ASS'Y		1
0LMK	LOCKING CABLE TIE		1	2X1B	RIP FENCE ASS'Y		1
0QGR	COMPRESSION SPRING		1	2X1D	CLAMP BAR		1
0R25	COLLAR		1	2X1E	LOCK HANDLE		1
10PM	COPPER BUSH		4	2X1G	SPECIAL NUT		1
145M	SPRING PIN		2	2X1Q	DRIVE BELT,POLY-V BELT		1
151G	O-RING ROD		2	2X1T	PUSH IN PIN		2
20LW	CR.RE. PAN HD. SCREW & WASHER	M5*0.8-16	10	2X1U	SLEEVE-RUBBER		1
22VD	PARALLEL PIN		1	2X23	ROCKER SWITCH		1
22VF	SLEEVE		1	2X55	SPACER		1
237F	BEVEL GEAR		1	2X5N	LEAD WIRE ASS'Y		1
237G	REINFORCE PLATE		1	2X5P	POWER CABLE		1
237T	SET PLATE		2	2X64	WHEEL CAUTION STICKER		1
237V	DUST GUARD		1	2X65	WHEEL CAUTION STICKER		1
237W	GUIDE BLOCK		1	2X79	SCALE (L)		1
237X	SPONGE		2	2X7A	SCALE (R)		1
237Y	WHEEL	#06	1	2X7H	CAUTION LABEL		1
237Z	SET PLATE		1	2X7J	LABEL		1
238G	LOCATION SEAT		2	2X7K	CAUTION STICKER		1
238K	ARM BRACKET		2	2XKU	HARDWARE BAG ASS'Y - U		1
238S	POINTER		1	2XZ9	COLLAR		1
238T	ROLLING WHEEL		2	2YBD	WARNING LABEL		2
239G	LINK PLATE		1	2YBU	TRADE-MARK LABEL		1
239H	SIDE COVER(LEFT)		1	2YEW	INSTRUCTIONS MANUAL		1
239J	SIDE COVER(RIGHT)		1	2YQ2	BLADE		1
23BA	SCREW	M6*1.0	2	2YQ3	HEX. SOC. HD. CAP BOLT	M8*1.25-75	4
23CN	HEX.SOCKET HD.CAP SCREWS	M6*1.0-40	4	2YR5	BUSH		2
23KE	HEX. NUT	M16*1.5,T=7	1	2YRC	HARDWARE BAG ASS'Y - T		1
23KS	BALL BEARING		2	2YRD	HARDWARE BAG ASS'Y - R		1
255N	HEX.SOCKET HD.CAP SCREWS	M8*1.25-20	4	2YRG	HARDWARE BAG ASS'Y - P		1
255V	WASHER		1	2YRK	HANDLE BAR ASS'Y		1
25JY	SWITCH MOUNTING	#06	1	2YVD	PLUNGER HOUSING ASS'Y		1
25MZ	SWITCH BOX		1	2YXD	COVER		1
				2222	TILTING SCALE		1

10 IN. (254 MM) STATIONARY TABLE SAW

PARTS LIST & SCHEMATIC FOR MOTOR

I.D.	Description	Size	Qty	I.D.	Description	Size	Qty
1314	CR. RE. PAN HD. SCREW	5/22x32UNC-1/4	2	153N	CAPACITOR COVER		1
1451	LEAD WIRE ASS'Y		1	153P	CAPACITOR TERMINAL COVER		2
0HVW	BALL BEARING	6202ZZ	1	153T	CAPACITOR TERMINAL COVER		2
0HVX	BALL BEARING	6203ZZ	1	25N5	INSULATE PLATE		1
0JAF	EXTERNAL TOOTH LOCK WASHER	φ5	1	25SH	CR.RE. PAN HD. SCREW & WASHER	10#-24UNC-1/4	4
0JBA	WAVE WASHER		1	2E7A	ARMATURE ASS'Y		1
0KF2	CR.-RE. PAN HD. SCREW	M3*0.5-6	2	2PWE	MOTOR REAR COVER	#06	1
0KRP	SERRATED TOOTHED HEXAGON FLANGE NUT	M5*0.8, T=5	4	2WF8	FRONT HOUSING		1
0KSR	STRAIN RELIEF	φ9.65	2	2WWD	MOTOR ASS'Y		1
0LYY	CONTACT PLATE	63mm T=2mm	1	2WWF	MOTOR HOUSING ASS'Y		1
0LZ0	CENTRIFUGAL STARTER	2P	1	2WWJ	FIELD ASS'Y	L=95 115V/230V 60Hz	1
0LZC	CAPACITOR		1	Y41A	SPRING PIN	M5*8 SK5+SK7	1
0Q1G	FAN		1	Y48V	CR. RE. PAN HD. SCREW	M5*0.8-230	4
0Q2L	CONNECTOR BOX COVER	#06	1	Y490	CR. RE. PAN HD. & WASHER SCREW	3/16x24UNCx3/8	6
0Q2T	CAPACITOR COVER	#06	1	Y49V	CR. RE. PAN HD. SCREW	3/16x24UNCx 3/8	1
144T	CAPACITOR		1	Y4C1	TERMINAL		2

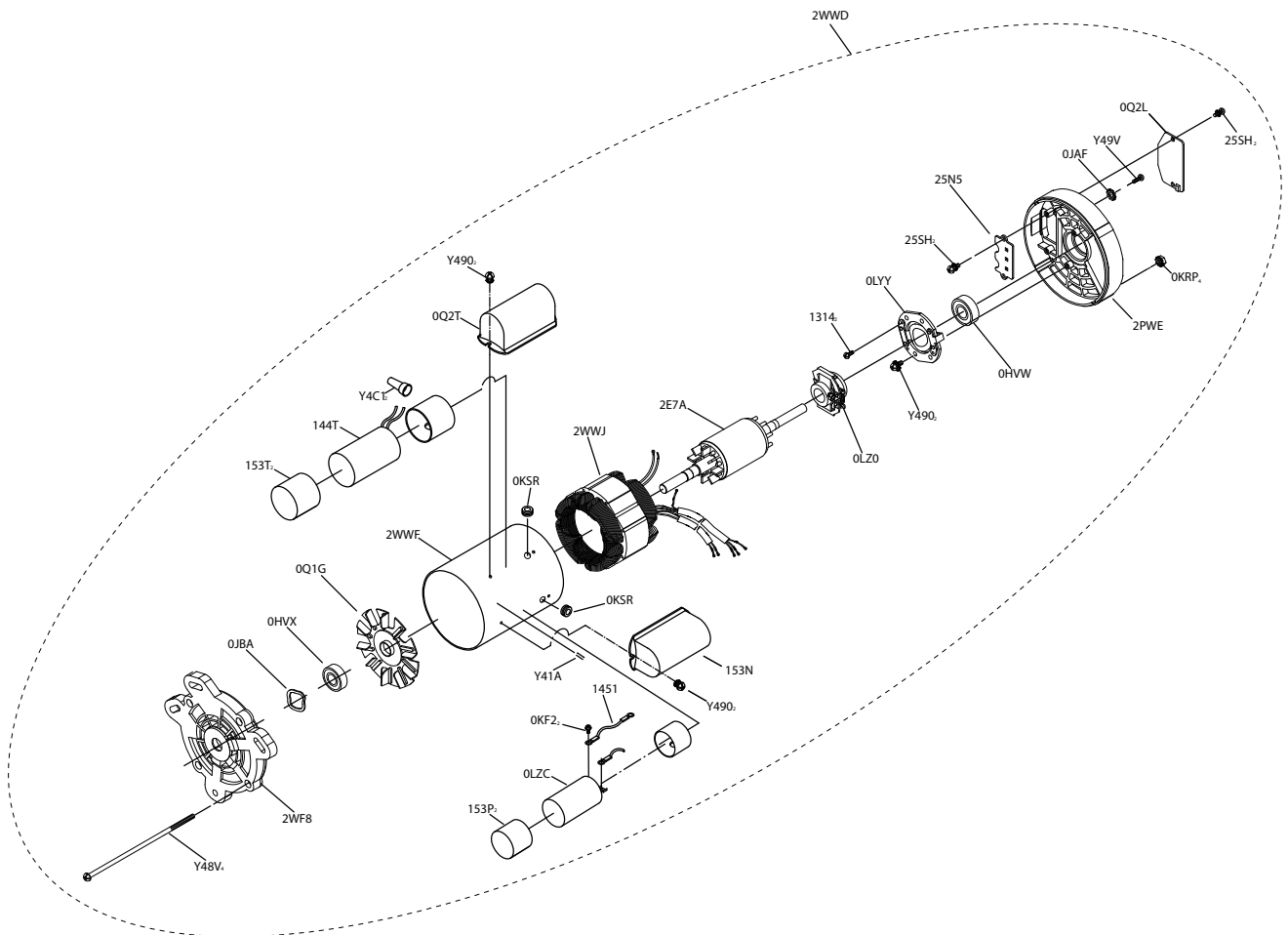

NOTES

WARRANTY

THREE YEAR LIMITED WARRANTY

PORTER-CABLE will repair, without charge, any defects due to faulty materials or workmanship for three years from the date of purchase. This warranty does not cover part failure due to normal wear or tool abuse. For further detail of warranty coverage and warranty repair information, visit www.portercable.com or call (888) 609-9779. This warranty does not apply to accessories or damage caused where repairs have been made or attempted by others. This warranty gives you specific legal rights and you may have other rights which vary in certain states or provinces.

In addition to the warranty, PORTER-CABLE tools are covered by our:

1 YEAR FREE SERVICE: PORTER-CABLE will maintain the tool and replace worn parts caused by normal use, for free, any time during the first year after purchase.

90 DAYS MONEY BACK GUARANTEE: If you are not completely satisfied with the performance of your PORTER-CABLE Power Tool for any reason, you can return it within 90 days from the date of purchase with a receipt for a full refund – no questions asked.

LATIN AMERICA: This warranty does not apply to products sold in Latin America. For products sold in Latin America, see country specific warranty information contained in the packaging, call the local company or see website for warranty information.

To register your tool for warranty service visit our website at www.portercable.com.

WARNING LABEL REPLACEMENT

If your warning labels become illegible or are missing, call (888) 609-9779 for a free replacement.

The following are PORTER-CABLE trademarks for one or more power tools and accessories: a gray and black color scheme; a “four point star” design; and three contrasting/outlined longitudinal stripes. The following are also trademarks for one or more Porter-Cable and Delta products: 2 BY 4[®], 890[™], Air America[®], AIRBOSS[™], Auto-Set[®], B.O.S.S.[®], Bammer[®], Biesemeyer[®], Builders Saw[®], Charge Air[®], Charge Air Pro[®], CONTRACTOR SUPERDUTY[®], Contractor’s Saw[®], Delta[®], DELTA[®], Delta Industrial[®], DELTA MACHINERY & DESIGN[™], Delta Shopmaster and Design[®], Delta X5[®], Deltacraft[®], DELTAGRAM[®], Do It. Feel it.[®], DUAL LASERLOC AND DESIGN[®], EASY AIR[®], EASY AIR TO GO[™], ENDURADIAMOND[®], Ex-Cell[®], Front Bevel Lock[®], Get Yours While the Sun Shines[®], Grip to Fit[®], GRIPVAC[™], GTF[®], HICKORY WOODWORKING[®], Homecraft[®], HP FRAMER HIGH PRESSURE[®], IMPACT SERIES[™], Innovation That Works[®], Jet-Lock[®], Job Boss[®], Kickstand[®], LASERLOC[®], LONG-LASTING WORK LIFE[®], MAX FORCE[™], MAX LIFE[®], Micro-Set[®], Midi-Lathe[®], Monsoon[®], MONSTER-CARBIDE[™], Network[®], OLDHAM[®], Omnijig[®], PC EDGE[®], Performance Crew[™], Performance Gear[®], Pocket Cutter[®], Porta-Band[®], Porta-Plane[®], Porter-Cable[®], Porter-Cable Professional Power Tools[®], Powerback[®], POZI-STOP[™], Pressure Wave[®], PRO 4000[®], Proair[®], Quicksand and Design[®], Quickset II[®], QUIET DRIVE TECHNOLOGY[™], QUIET DRIVE TECHNOLOGY AND DESIGN[™], Quick-Change[®], QUIK-TILT[®], RAPID-RELEASE[™], RAZOR[®], Redefining Performance[®], Riptide[®], Safe Guard II[®], Sand Trap and Design[®], Sanding Center[®], Saw Boss[®], Shop Boss[®], Sidekick[®], Site Boss[®], Speed-Bloc[®], Speedmatic[®], Stair Ease[®], Steel Driver Series[®], SUPERDUTY[®], T4 & DESIGN[®], THE AMERICAN WOODSHOP[®], THE PROFESSIONAL EDGE[®], Thin-Line[®], Tiger Saw[®], TIGERCLAW[®], TIGERCLAW AND DESIGN[®], Torq-Buster[®], TRU-MATCH[®], T-Square[®], Twinlaser[®], Unifence[®], Uniguard[®], UNIRIP[®], UNISAW[®], UNITED STATES SAW[®], Veri-Set[®], Versa-Feeder[®], VIPER[®], VT[™], VT RAZOR[™], Water Driver[®], WATER VROOM[®], Waveform[®], Whisper Series[®], X5[®], YOUR ACHIEVEMENT. OUR TOOLS.[®] Trademarks noted with ® are registered in the United States Patent and Trademark Office and may also be registered in other countries. Other trademarks may apply.

PORTER-CABLE and the PORTER-CABLE logo are registered trademarks of PORTER-CABLE and are used under license. All rights reserved.

PORTER  CABLE.

Power Tool Specialists, Inc.
684 Huey Road, Rock Hill, SC 29730
(888) 609-9779
www.portercable.com